

# Liquid ring compressors

## LPH 70123, LPH 70530, LPH 70540

**Compression pressure:** 0,2 to 1,5 bar  
**Suction volume flow:** 550 to 1850 m<sup>3</sup>/h

### CONSTRUCTION TYPE

Sterling SIHI liquid ring compressors are displacement compressors of simple and robust construction. They have the following important features:

- Handling of nearly all gases and vapours
- non-polluting due to nearly isothermal compression
- oil-free, as no lubrication in the working chamber
- additional liquid can be handled with the gas flow
- easy in maintenance and reliable operation
- low noise and nearly free of vibrations
- wide choice of material, therefore applicable nearly everywhere
- incorporated central drain
- no metallic contact of the rotating parts

The Sterling SIHI liquid ring compressors LPH 70123, LPH 70530 and LPH 70540 are single-stage compressors. They can be applied without modification as vacuum pump up to a suction pressure of 120 mbar (see catalogue part LI 5).



### APPLICATION

Handling and compressing of dry and humid gases; entrained liquid can be handled during normal duty. The compressors are applied in all fields where a compression over pressure of up to 1,5 bar has to be created by robust compressors and only a small increase in temperature is admissible during compression.

Fields of application are e.g.:

- the plastics industry, for the recovery of process gases as vinyl chloride
- the petrochemical industry, for the compression of combustible gases as gasoline vapours or hydrogen
- transport of gases in general, e.g. to a reactor

### NOTE

During operation the compressor must continuously be supplied with service liquid, normally water, in order to eliminate the heat resulting from the gas compression and in order to replenish the liquid ring, because part of the liquid is leaving the compressor together with the gas. This liquid can be separated from the gas in a pressure liquid separator ( see catalogue part accessories).

It is possible to reuse the service liquid. The compressors are equipped with a device by which the contaminated service liquid can continuously be drained during operation, if necessary.

The direction of rotation is clockwise, when looking from the drive on the pump.

### GENERAL TECHNICAL DATA

Pump type		unit	LPH 70123	LPH 70530	LPH 70540
Speed	50 Hz	rpm	975	975	975
	60 Hz		1175	1175	1175
Max. compression over pressure		bar		1,5	
Hydraulic test (over pressure)		bar		3	
Moment of inertial of the rotating pump parts and the water filling		kg · m <sup>2</sup>	1,36	1,76	2,26
Sound pressure level of measuring area		dB (A)	81	81	81
			82	82	82
Min. pulley diameter permissible in case of V-belt drive		mm	315	315	400
			355	355	
Max. gas temperature	dry	°C		200	
	saturated			100	
Service liquid	max. admissible temperature	°C		80	
	max. viscosity	mm <sup>2</sup> /s		90	
	max. density	kg/m <sup>3</sup>		1200	
	volume up to shaft level	liter	32	35	38

The combination of several limiting values is not admissible.

## Material design

Item.	COMPONENTS	MATERIAL DESIGN	
		02	42
0001, 0002	Casing	0.6025	1.4408
0010, 0011	Guide disk	0.6025	1.4408
0030	Vane wheel impeller	1.0570	1.4517
0035	Central body	1.0038	1.4571
0200	Shaft	1.0503	
0270	Shaft sleeve	1.4027.05	1.4571
0400	Gland packing	GORE	-
0500, 0600	Mechanical seal	Cr-steel / carbon / Perbunan	Cr Ni Mo-steel / carbon / Viton

## Sectional drawing LPH 70123, LPH 70530, LPH 70540

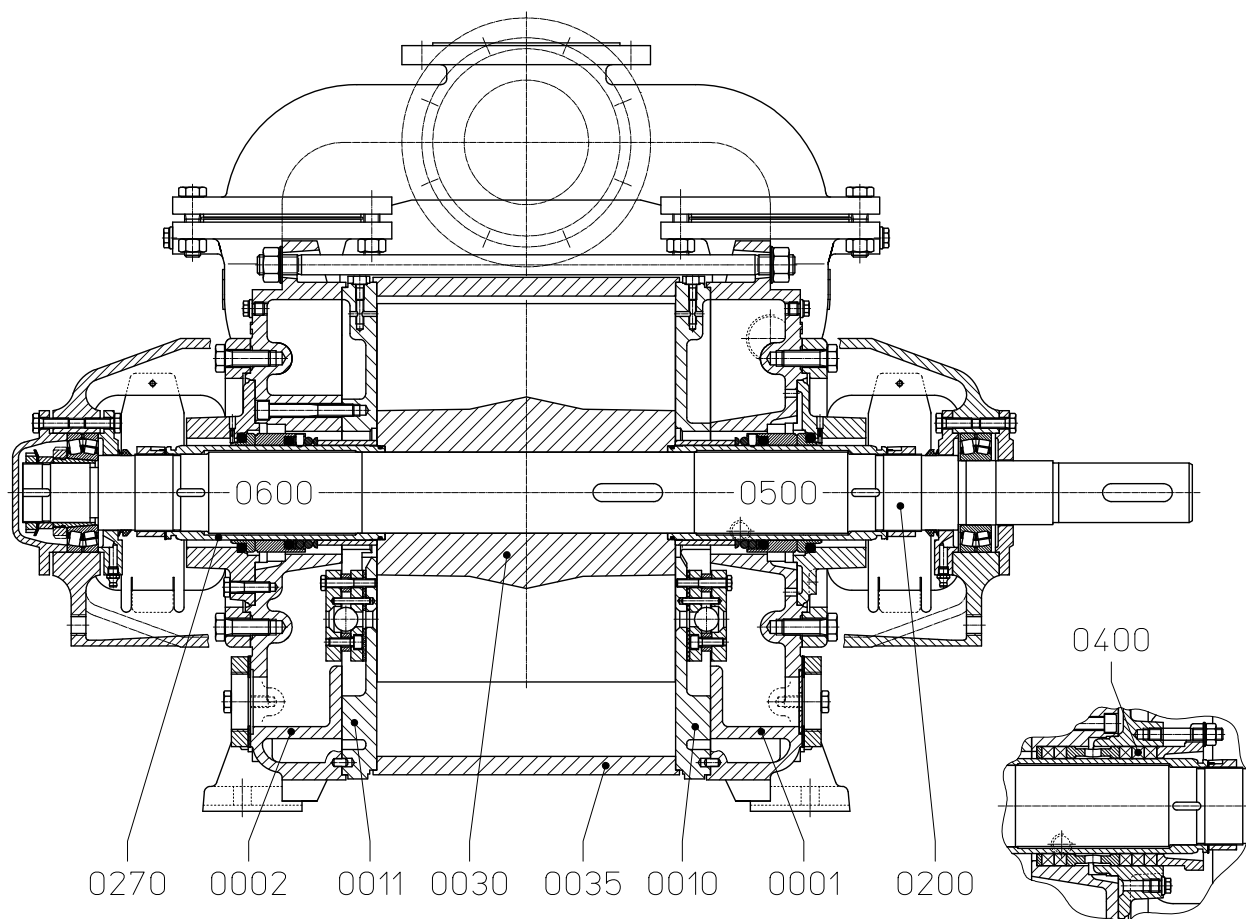

## Suction volume flow and power absorption LPH 70123

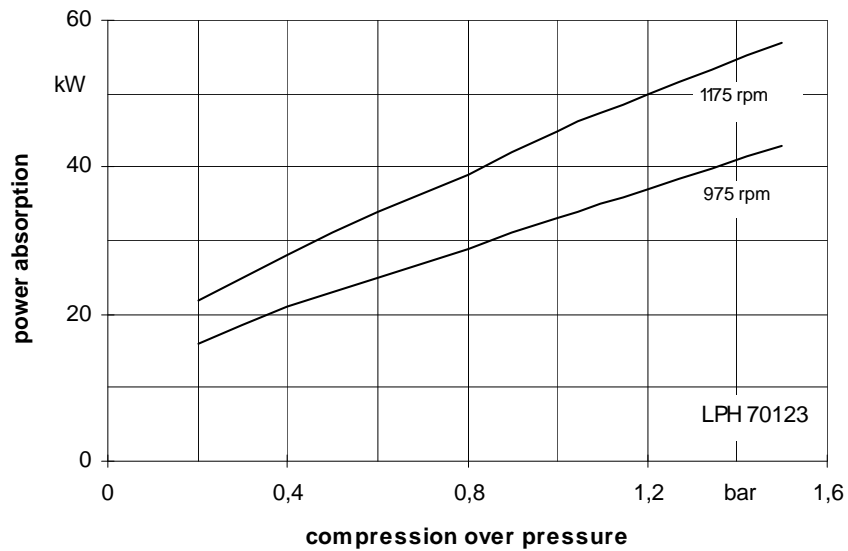
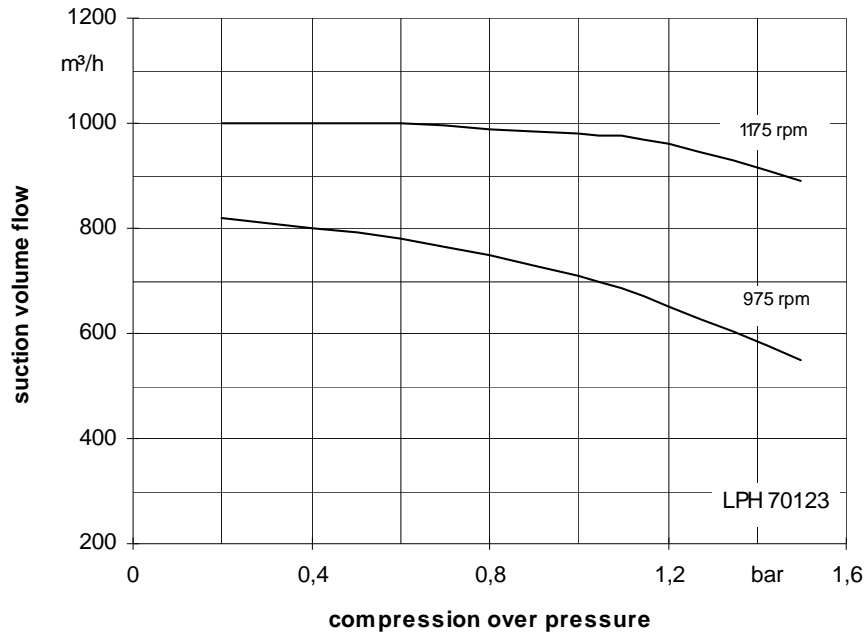

The values indicated for volume flow and power absorption are valid for compression of dry air at 20°C from atmospheric pressure (1013 mbar) to the respective compression pressure with water at 20°C as service liquid. Tolerance of the curve values is 10 %. The compression pressure in bar is indicated as pressure above the atmospheric pressure.

The data indicated change with deviating service conditions, such as deviating physical data of the gas to be handled or of the service liquid (vapour pressure, temperature, density, viscosity) when handling entrained liquid, at a suction pressure deviating from atmospheric pressure, when handling gas-vapours mixtures.

For determination of service data for deviating service conditions please see catalogue section TH.

## Suction volume flow and power absorption LPH 70530

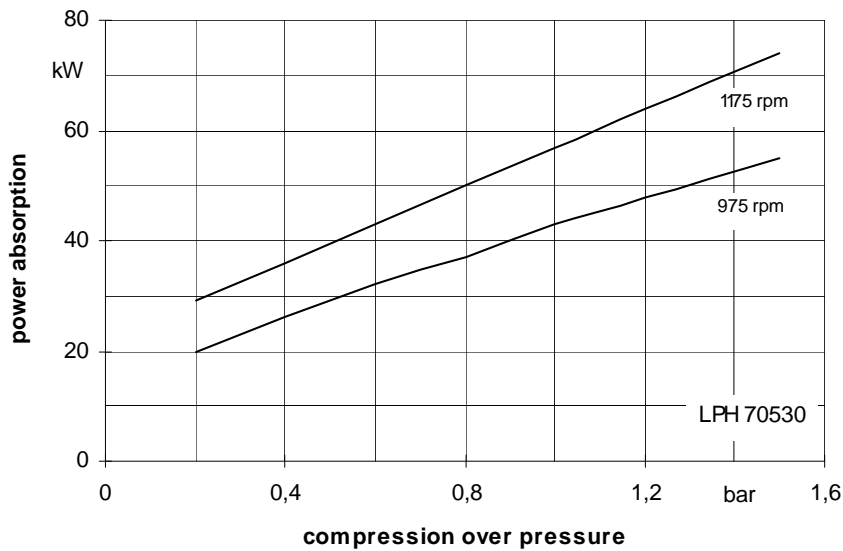
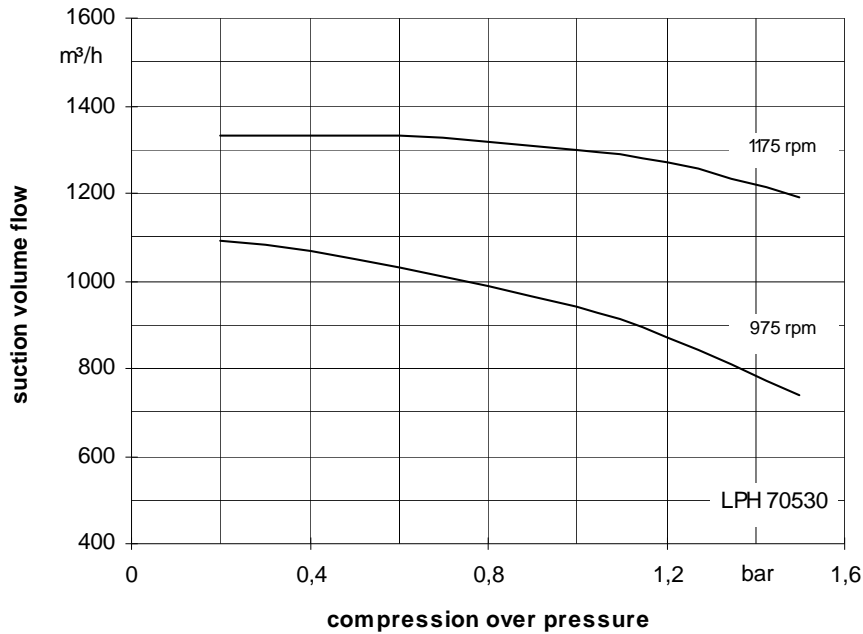

The values indicated for volume flow and power absorption are valid for compression of dry air at 20°C from atmospheric pressure (1013 mbar) to the respective compression pressure with water at 20°C as service liquid. Tolerance of the curve values is 10 %. The compression pressure in bar is indicated as pressure above the atmospheric pressure.

The data indicated change with deviating service conditions, such as deviating physical data of the gas to be handled or of the service liquid (vapour pressure, temperature, density, viscosity) when handling entrained liquid, at a suction pressure deviating from atmospheric pressure, when handling gas-vapours mixtures.

For determination of service data for deviating service conditions please see catalogue section TH.

## Suction volume flow and power absorption LPH 70540

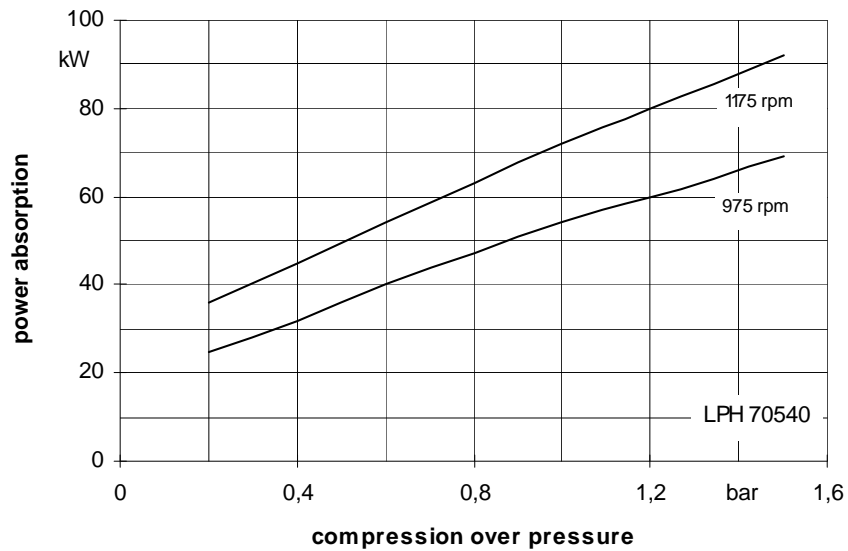
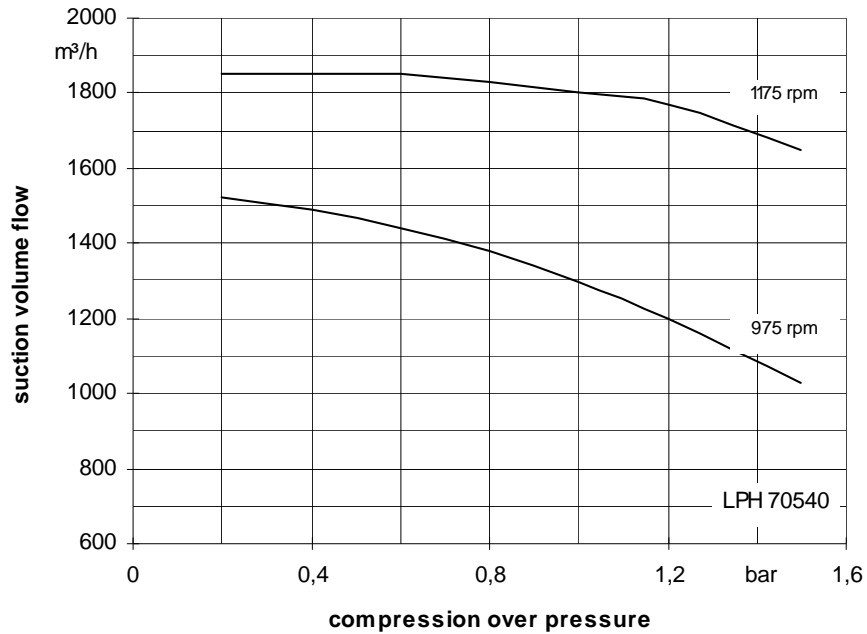

The values indicated for volume flow and power absorption are valid for compression of dry air at 20°C from atmospheric pressure (1013 mbar) to the respective compression pressure with water at 20°C as service liquid. Tolerance of the curve values is 10 %. The compression pressure in bar is indicated as pressure above the atmospheric pressure.

The data indicated change with deviating service conditions, such as deviating physical data of the gas to be handled or of the service liquid (vapour pressure, temperature, density, viscosity) when handling entrained liquid, at a suction pressure deviating from atmospheric pressure, when handling gas-vapours mixtures.

For determination of service data for deviating service conditions please see catalogue section TH.

**Dimension table LPH 70123**

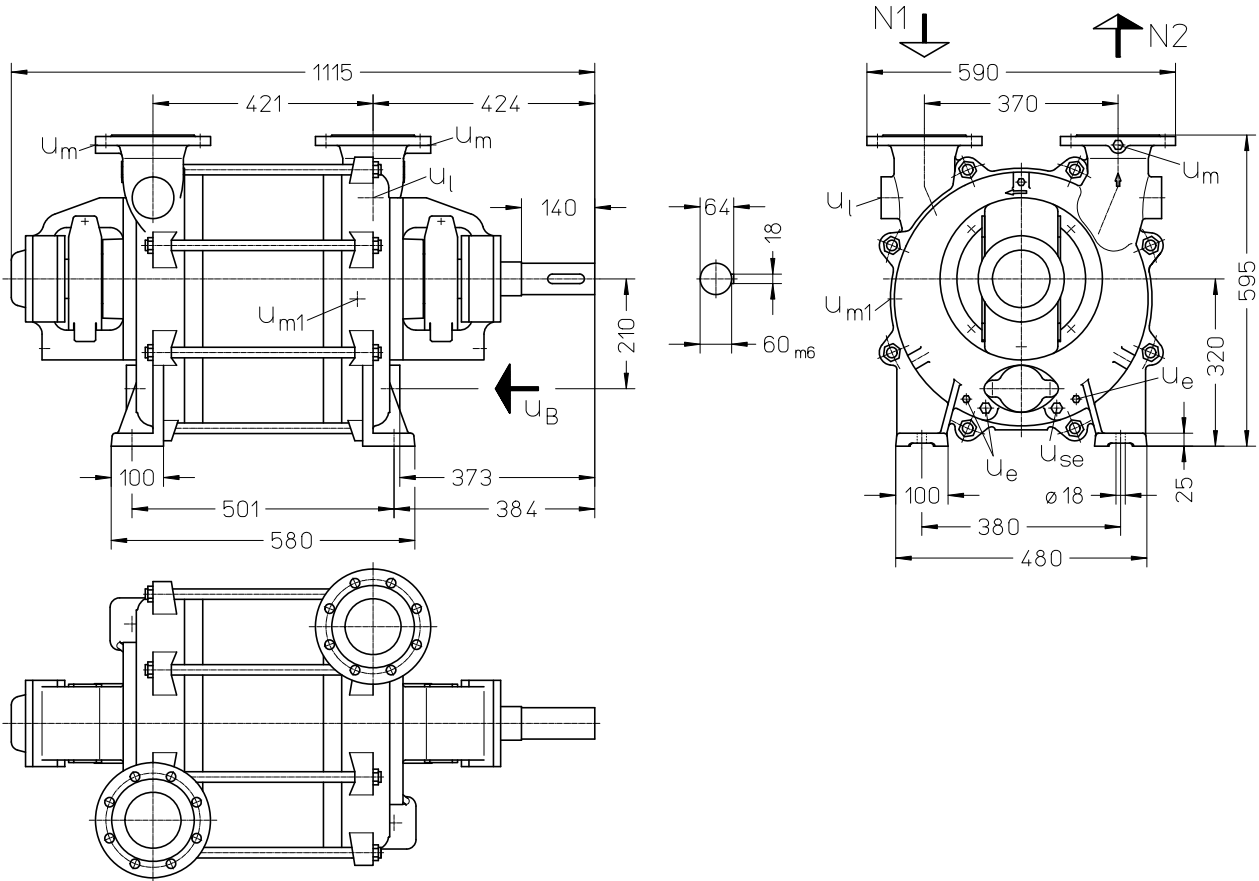

**weight: abt. 370 kg**

- N 1 = gas inlet DN 100
- N 2 = gas outlet DN 100
- u<sub>B</sub> = connection for service liquid G 2
- u<sub>e</sub> = drainage (screwed plug) G ¼
- u<sub>l</sub> = connection for vent cock G 1 ½
- u<sub>m</sub> = connection for pressure gauge G ¾
- u<sub>m1</sub> = connection for drain valve G ½
- u<sub>se</sub> = connection for dirt drain G ½

flange connection to DIN 2501 PN 10	
DN	100
k	180
D	220
number x d <sub>2</sub>	8 x 18

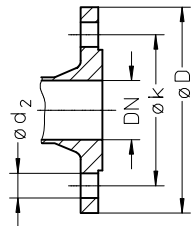

**Dimension table LPH 70530, LPH 70540**

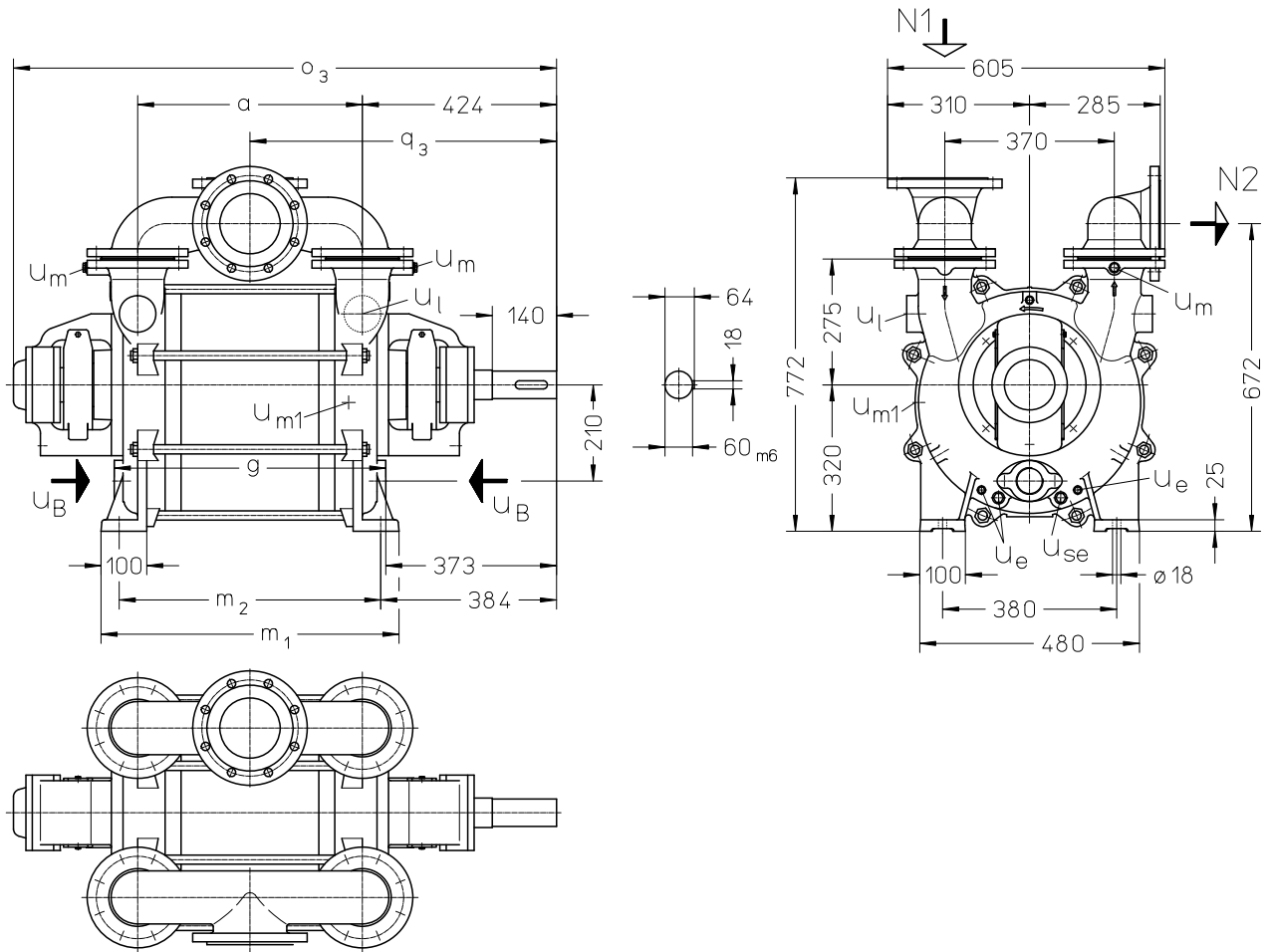

- N 1 = gas inlet DN 125
- N 2 = gas outlet DN 125
- UB = connection for service liquid G 2
- Ue = drainage (screwed plug) G ¼
- U<sub>l</sub> = connection vent cock G 1 ½
- Um = connection for pressure gauge G ¾
- Um1 = connection for drain valve G ½
- Use = connection for dirt drain G ½

	a	g	m <sub>1</sub>	m <sub>2</sub>	o <sub>3</sub>	q <sub>3</sub>	weight abt. kg
LPH 70530	491	593	650	571	1185	669	490
LPH 70540	591	693	750	671	1285	719	540

flange connection to DIN 2501 PN 10	
DN	125
k	210
D	250
number x d <sub>2</sub>	8 x 18

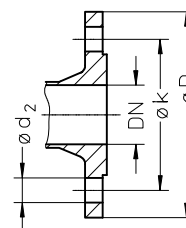

**Fresh water requirement** in [m<sup>3</sup>/h] dependent on compression pressure, speed, mode of operation and difference in temperature

pump	speed [rpm]	compression pressure in bar																			
		0,4					0,8					1,2					1,5				
		KB				FB	KB				FB	KB				FB	KB				FB
		difference in temperature [°C]					difference in temperature [°C]					difference in temperature [°C]					difference in temperature [°C]				
30	20	10	5	30	20	10	5	30	20	10	5	30	20	10	5						
LPH 70123	975	0,45	0,60	0,90	1,20	1,8	0,64	0,86	1,32	1,79	2,8	0,84	1,14	1,77	2,46	4	0,99	1,35	2,12	2,98	5
	1175	0,54	0,70	1,00	1,26	1,7	0,77	1,00	1,43	1,82	2,5	1,02	1,33	1,93	2,49	3,5	1,20	1,59	2,35	3,08	4,5
LPH 70530	975	0,61	0,85	1,36	1,96	3,5	0,87	1,21	1,94	2,80	5	1,15	1,59	2,60	3,79	7	1,33	1,85	3,04	4,48	8,5
	1175	0,78	1,04	1,57	2,11	3,2	1,10	1,48	2,27	3,08	4,8	1,43	1,93	2,98	4,09	6,5	1,68	2,27	3,54	4,91	8
LPH 70540	975	0,75	1,02	1,63	2,32	4	1,08	1,48	2,33	3,27	5,5	1,40	1,92	3,06	4,34	7,5	1,62	2,23	3,57	5,12	9
	1175	0,96	1,28	1,92	2,55	3,8	1,34	1,78	2,65	3,51	5,2	1,73	2,31	3,47	4,64	7	2,01	2,70	4,10	5,53	8,5

FB = fresh liquid service

KB = combined liquid service with service water 30 °C, 20 °C, 10 °C, 5 °C warmer than the fresh water.

**Data regarding the size - order notes**

series + size	hydraulics + bearings	shaft sealing	material design	case sealing
	B• 2 antifriction bearings •N 1 shaft end, clockwise	041 double gland packing 135 mechanical seal, SIHI-FN	02 normal design cast iron, but without non-ferrous metal 42 main parts of Cr Ni Mo steel	0 liquid seal
LPH 70123	BN	041	02	0
70530		135	02	
70540		135	42	



## Accessories

Recommended accessories			LPH 70123	LPH 70530	LPH 70540
<b>Pressure liquid separator</b>  material design 130 / St-galvanized 172 / 1.4571  service liquid line material design 072 / St 37-0 172 / 1.4571  bend material design 072 / St 37-0	type weight SIHI part No.  SIHI part No.  SIHI part No.		XBd 2312 107 kg 35 000 332 35 000 333		
			35 003 173 35 003 174	35 003 176 35 003 177	35 003 178 35 003 179
			35 003 235	-	-
<b>Liquid discharge trap</b>  material design 762 / GG20+1.4541  reduction material design 072 / St 37-0  hanging gas line material design 072 / St 37-0	type / weight SIHI part No.  SIHI part No.  SIHI part No.		XUk 3302 / 22 kg 43 014 805	XUk 4102 / 31 kg 43 014 809	
			35 009 225	-	
			upon request	upon request	
<b>Motor</b> dependent on operating point, for example IP 55     EEx e II T3	size power weight  size power weight		280S 280M 45 kW 55 kW 540 kg 580 kg	280 M 315 S 55 kW 75 kW 580 kg 770 kg	315 S 315 M 75 kW 90 kW 770 kg 830 kg
			280M 315S 46 kW 64 kW 625 kg 910 kg	315S 315M 64 kW 76 kW 910 kg 960 kg	315M 315M 76 kW 95 kW 960 kg 1000 kg
<b>Coupling</b> for motor IP 55 pump side motor side  for motor EEx e II T3 pump side motor side	type / weight SIHI part No.  type / weight SIHI part No.		upon request		
			upon request		
<b>Contact safety device</b> material design 076 / steel 345 / 2.0321	SIHI part No.		upon request		
<b>Base frame</b> material design 081 / RSt 37-2  for motor size 280 M material design 081 / RSt 37-2	SIHI part No. weight  SIHI part No. weight		35 002 939 180 kg	35 002 944 190 kg	35 002 950 180 kg
				35 002 942 190 kg	

Any changes in the interest of technical development are reserved.

### Sterling SIHI GmbH

Lindenstraße 170, D-25524 Itzehoe, Germany, Telephone +49 (0) 48 21 / 7 71 - 01, Fax +49 (0) 48 21 / 7 71 - 274