

LPH 40106, LPH 40411 LPH 45008, LPH 45316

Pressure range: 0.2 to 1.5 bar
Suction volume range: 55 to 175 m³/h

CONSTRUCTION

Sterling SIHI liquid ring compressors are displacement compressors with a simple but robust construction and the following features and benefits:

- Can handle almost all gases and vapours
- Near isothermal compression
- Oil free with no internal lubrication required
- Able to handle quantities of liquid carry over
- Low maintenance and safe operation
- Low noise and almost vibration free
- Available in a wide range of materials
- Broad range of applications
- O-Ring sealing as standard
- Central drain plug as standard
- Built in solids drain
- Rotating metallic parts are non contacting to minimise wear

The Sterling SIHI liquid ring compressors LPH 40106 and LPH 40411 are one stage. They can be used without modification as vacuum pumps up to a suction pressure of 150 mbar (for more information see Catalogue Part LI 2).

The Sterling SIHI liquid ring compressors LPH 45008 and LPH 45316 are two stage. They can be used without modification as vacuum pumps up to a suction pressure of 33 mbar (for more information see Catalogue Part LII 3).

APPLICATION

Transport and compression of dry gases and saturated vapours. The pumps can also handle liquids. Compressors are used typically where a pressure of up to 1.5 bar is required and only a limited temperature increase due to the compression is permitted.

Applications include:

- The plastics processing industry for the recovery of gases such as vinyl chloride
- The petrochemical industry for the compression of flammable gases such as petroleum vapours or hydrogen
- Gas transfer e.g. to a reactor.



NOTE

By continuously feeding the compressor with a small amount of service liquid (usually water), the heat due to gas/vapour compression is conducted away. This also replenishes the liquid ring and ensures that it does not become saturated with process media. The condensed gas and fluid can be separated in a liquid separator (see Accessories Catalogue). Recharging the pump with service liquid at ambient temperature enables the unit to condense evacuated gases/vapours. More information is provided in the accessory catalogues.

The rotation of the pump is clockwise when viewed from the drive side.

GENERAL TECHNICAL DATA

Pump Type	Units	LPH 40106	LPH 40411	LPH 45008	LPH 45316
Speed	Normal speed = 50 Hz 60 Hz	1450 1750	1450 1750	1450 1750	1450 1750
Maximum compression over atmospheric	bar	0.6 or 0.8 ¹⁾	0.8 or 1.0 ¹⁾	1.5	1.2
Water pressure test (overpressure)	bar	3.0		3.0	
Moment of inertia of rotating parts of pump and of water content	kg · m ²	0.0375	0.05	0.05	0.09
Surface noise level	dB (A)	69...70		69...70	
Minimum permissible pulley diameter for V- belt drive	mm	160	180	160	180 or 200 ¹⁾
Maximum gas temperature	dry saturated	200 100		200 100	
Service liquid					
Maximum permissible temperature	°C	80		80	
Minimum permissible temperature	°C	10		10	
Maximum viscosity	mm ² /s	90		90	
Maximum density	kg/m ³	1200		1200	
Liquid capacity up to middle of shaft	litre	3.5	4.5	4.0	7.0

In selecting a compressor, avoid choosing one which is likely to be operating at a combination of its maximum permissible limits.

¹⁾ at 60Hz

Materials

Position Number	Component	Materials	
		OK	4B
10.60	Casing	0.6025	1.4408
10.90	Central Body		
13.70, 13.71*	Guide Disc		1.4404
21.00	Shaft	1.4308	1.4408
23.50, 23.51*	Impeller		
43.30, 43.31	Mechanical Seal Type SIHI FK (AG*)	Cr-Steel / Carbon / Butadiene Rubber	Cr Ni Mo-Steel / Carbon / Viton

* only on LPH 45008, 45316
other executions on request

Cut away Diagram LPH 40106, LPH 40411

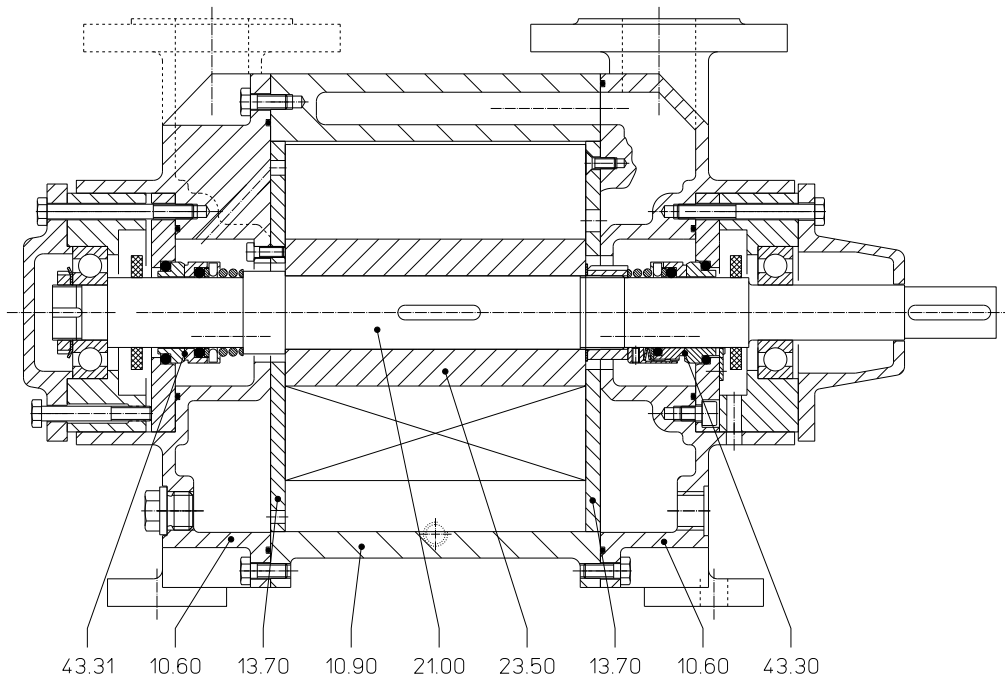

Cut away Diagram LPH 45008, LPH 45316

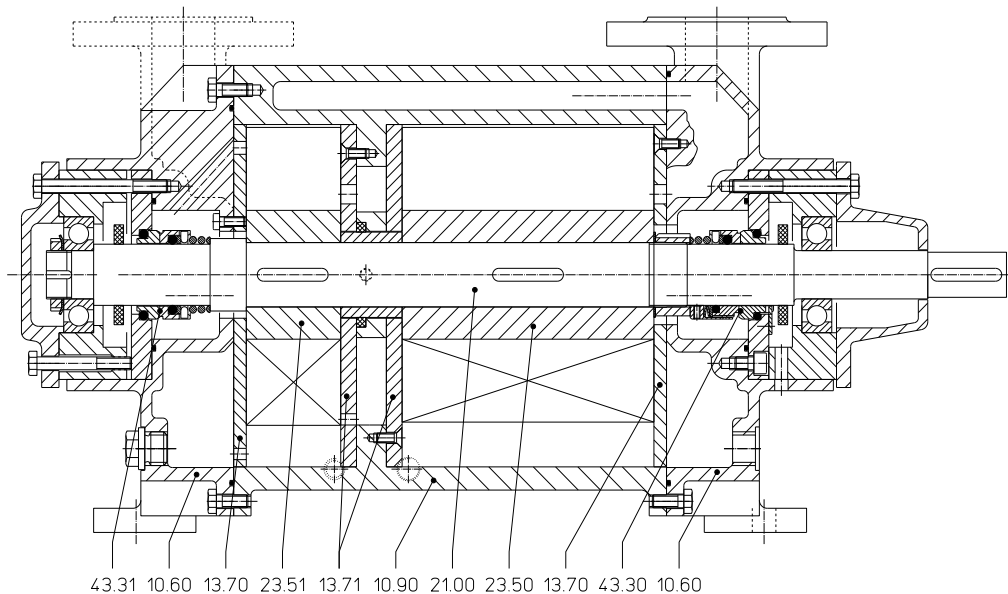

Performance

LPH 40106

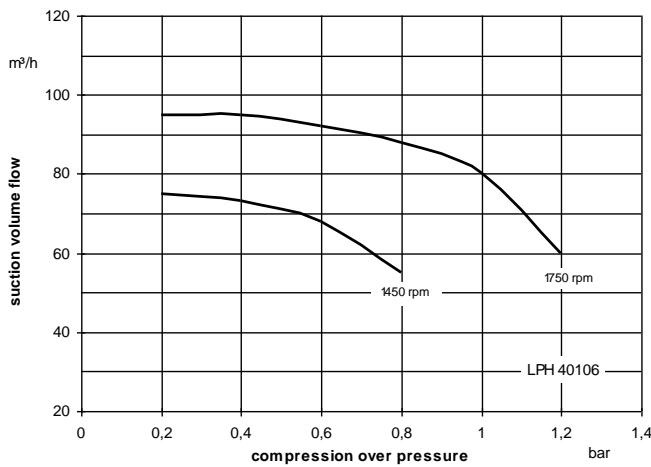

LPH 40411

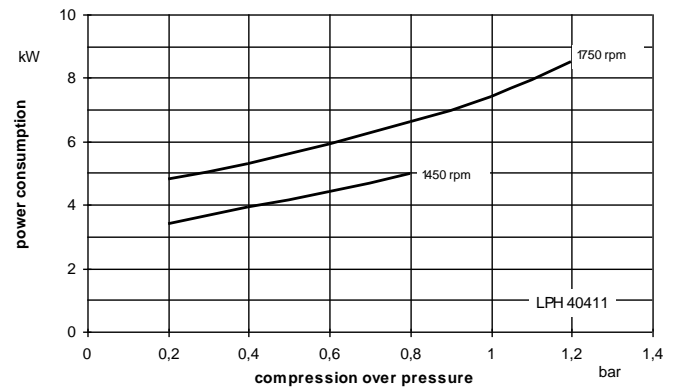
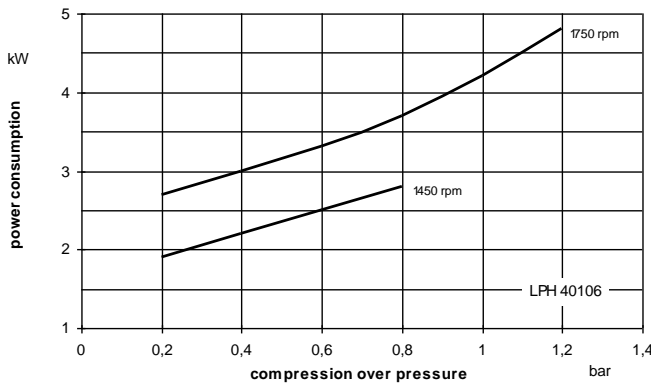
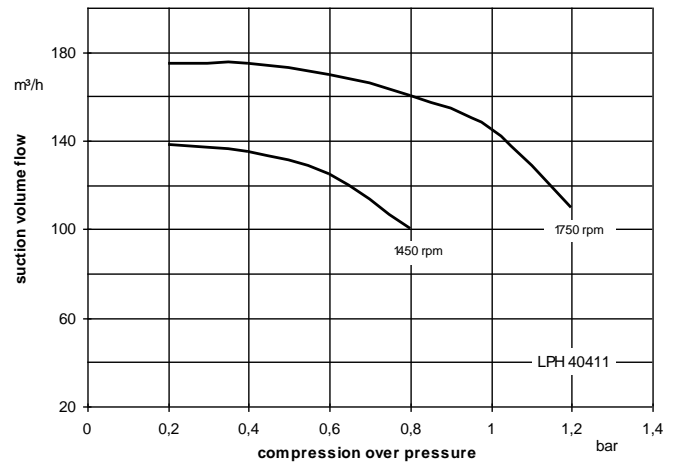

The suction volume and power consumed values are valid for compressing dry air at 20°C at atmospheric pressure (1013 mbar) to the corresponding overpressure using water as the service liquid with a temperature of 20°C. The curve tolerance is 10%. The compression pressure is expressed in bar relative to ambient air pressure.

The values quoted will change with variations in the operating conditions e.g. when the physical properties of the gas to be compressed change or there are changes in the service liquid (vapour pressure, temperature, density, viscosity), with liquid, carry over, with suction pressures different from atmospheric pressure or with gas – vapour mixtures.

To determine operating data when the operating conditions vary from those quoted, please consult Technical Catalogue Part TH.

Performance

LPH 45008

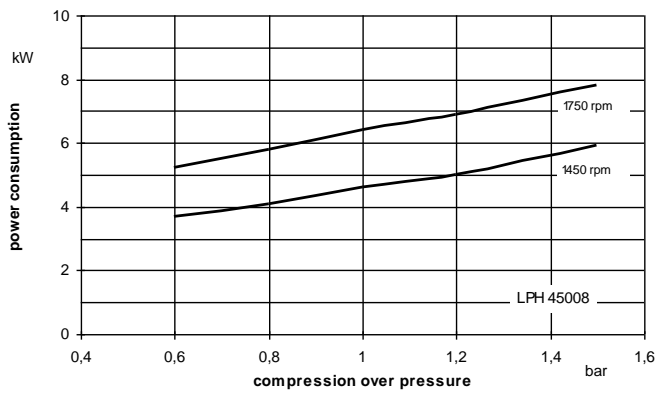
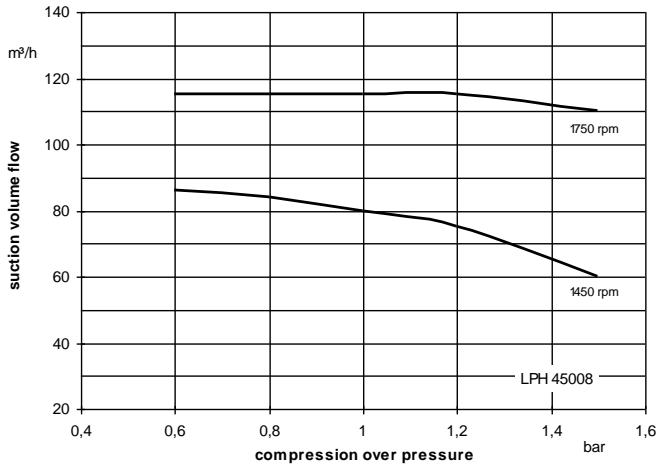

LPH 45316

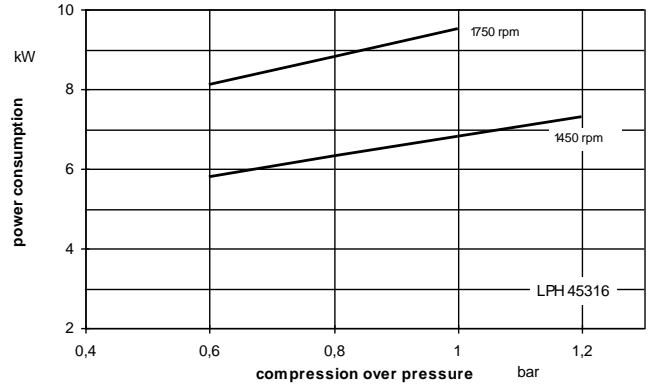
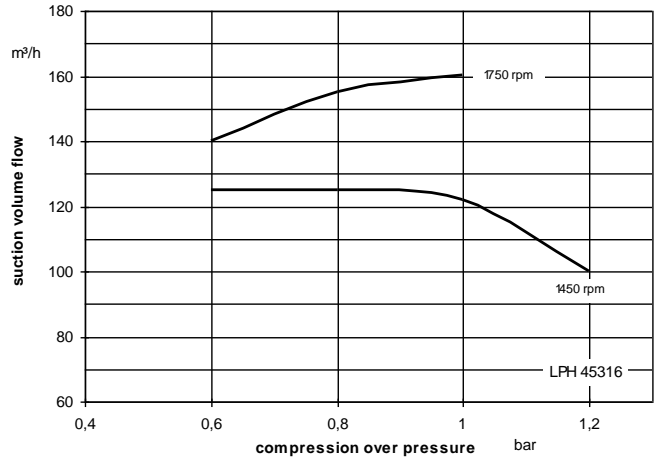

The suction volume and power consumed values are valid for compressing dry air at 20°C at atmospheric pressure (1013 mbar) to the corresponding overpressure using water as the service liquid with a temperature of 20°C. The curve tolerance is 10%. The compression pressure is expressed in bar relative to ambient air pressure.

The values quoted will change with variations in the operating conditions e.g. when the physical properties of the gas to be compressed change or there are changes in the service liquid (vapour pressure, temperature, density, viscosity), with liquid carry over, with suction pressures different from atmospheric pressure or with gas – vapour mixtures.

To determine operating data when the operating conditions vary from those quoted, please consult Technical Catalogue Part TH.

Dimensions LPH 40106, LPH 40411, LPH 45008, LPH 45316

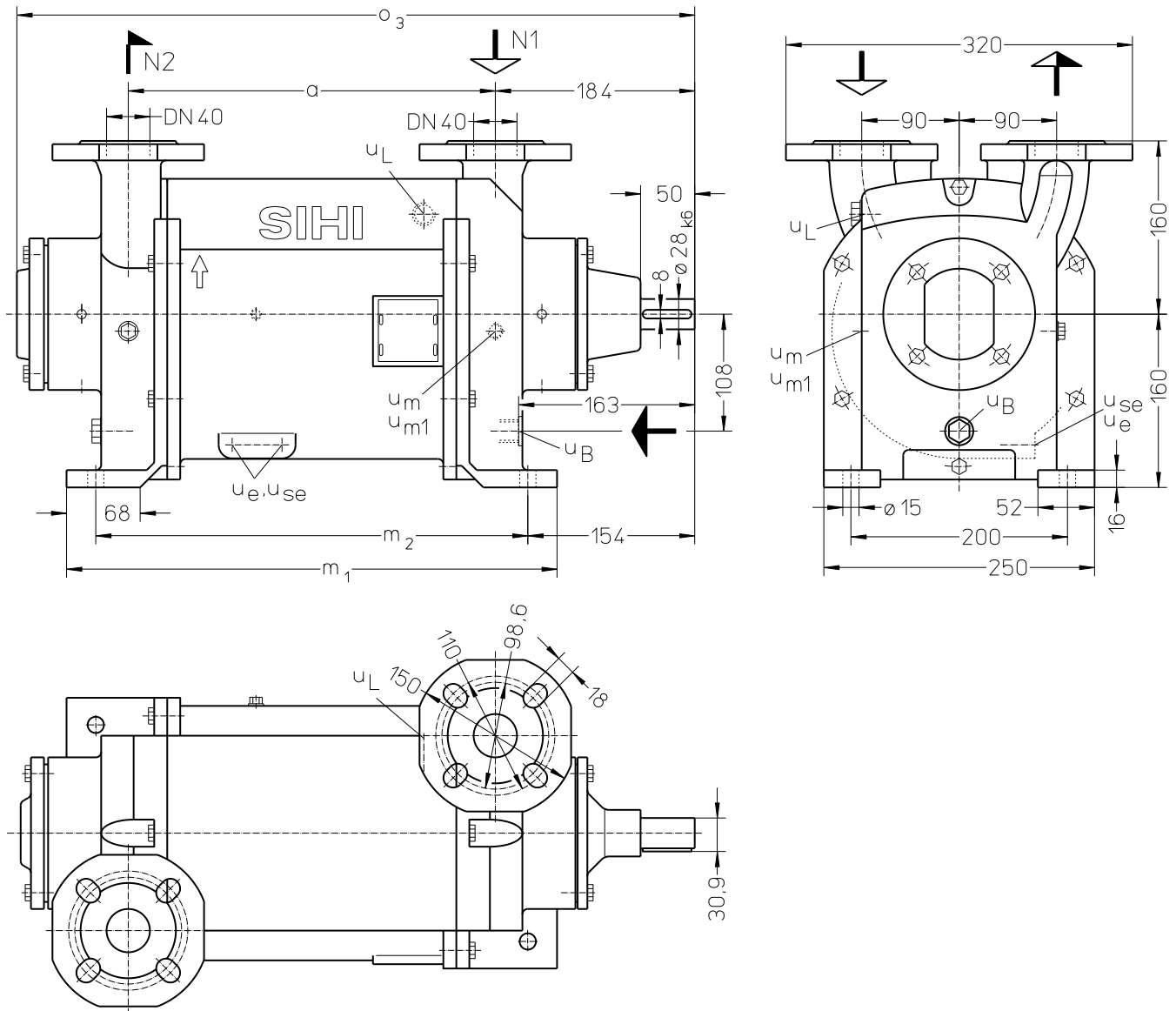

- N 1 = Gas inlet DN 40 (according to DIN EN 1092 PN 10)
Gas inlet 1 1/2" (according to ANSI 150 lbs)
- N 2 = Gas outlet DN 40 (according to DIN EN 1092 PN 10)
Gas outlet 1 1/2" (according to ANSI 150 lbs)
- u_B = Connection for service liquid G 1/2
- u_e = Connection for drain G 1/8
- u_{se} = Connection for dirt drain G 1/8
- u_L = Connection for vent valve G 1/2
- u_m = Connection for pressure gauge G 1/4
- u_{m1} = Connection for drainage valve or liquid level sensor G 1/4

type	a [mm]	m_1 [mm]	m_2 [mm]	o_3 [mm]	approx. weight [kg]
LPH 40106	144	258	204	431	55
LPH 40411	194	308	254	481	60
LPH 45008	239	353	299	526	65
LPH 45311	269	383	329	556	70

Arrangement Drawing LPH 40106, LPH 40411, LPH 45008, LPH 45316 with pressure liquid separator

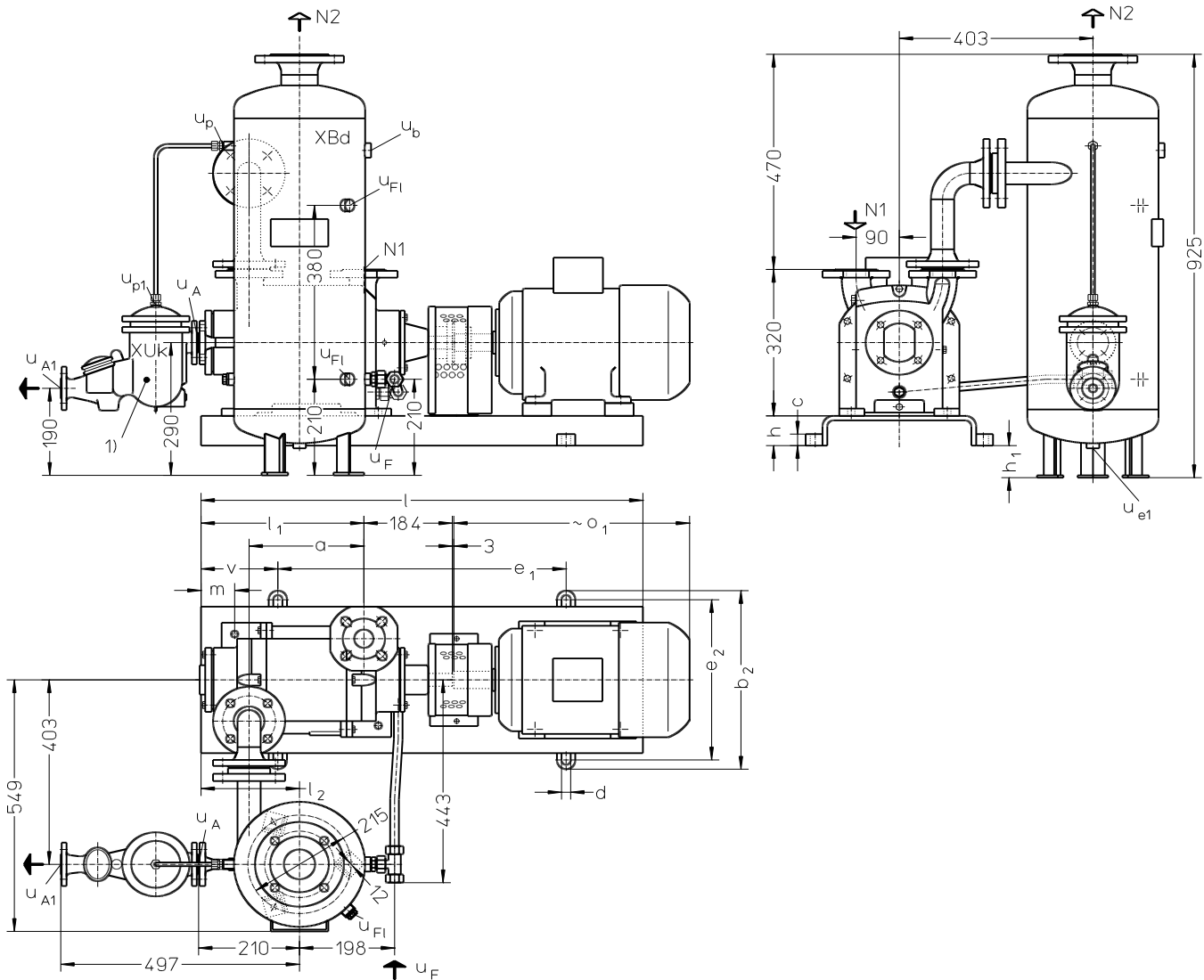

1) = Support required

N 1 = Gas inlet DN 40

N 2 = Gas outlet DN 65, 4 bolt

u_F = Connection for make-up liquid 18 mm

u_A = Liquid discharge DN 15

u_{A1} = Liquid discharge DN 15

u_{e1} = Drain connection G ½

u_b = Connection for safety valve G ¾

u_{Fl} = Connection for liquid level indicator G ½

u_p = Connection for gas balance pipe G ¼

u_{p1} = Connection for gas balance pipe G ¼

Flange connection dimensions according to DIN EN 1092 PN 10 [mm]			
DN	15	40	65
k	65	110	145
D	90	150	185
Number x d ₂	4 x 14	4 x 18	4 x 18

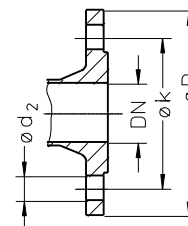

Dimensions on Arrangement Drawing LPH 40106, LPH 40411, LPH 45008, LPH 45316

Type	E-Motor 50 Hz		Base-plate	a [mm]	b ₂ [mm]	c [mm]	d [mm]	e ₁ [mm]	e ₂ [mm]	h [mm]	h ₁ [mm]	l [mm]	l ₁ [mm]	l ₂ [mm]	m [mm]	v [mm]	o ₁ * [mm]	2)	3)						
	Size	kW																ca. [kg]	ca. [kg]						
LPH 40106	100L	3.0	S301	144	390	25	19	480	350	65	70	730	224	185	50	125	372	110	155						
	100L	2.5																393	120	165					
	112M	4.0																							
	112M	3.6																							
LPH 40411	112M	4.0	S303	194	390	25	19	600	350	65	70	920	274	185	50	160	393	130	175						
	132S	5.0															453	145	190						
	132S	5.5																							
	132M	6.8																							
LPH 45008	132S	5.5	S303	239	390	25	19	600	350	65	70	920	339	205	70	160	453	155	200						
	132S	5.0															491	150	195						
	132M	7.5																							
	132M	6.8																							
LPH 45316	132M	7.5	S344	339	450	30	24	660	400	80	55	1020	439	205	70	180	453	180	225						
	132M	6.8	S385									490					30	24	740	440	80	1140	491	195	240
	160M	11.0																							
	160M	10.0																							

* = Dimensions depend upon motor supplier

2) = Weight for Compressor + Motor + Coupling + Coupling Guard + Baseplate

3) = as 2) + Pressure Separator + Pressure Line + Liquid Drain

Make-up Liquid in [m³/h] dependent on Compression Pressure, Speed, Method of Operation and Temperature Difference

Type	Speed [rpm]	Compression Pressure in [bar]																			
		0.2				0.6				0.8				1.2							
		KB				FB	KB				FB	KB				FB					
		Temperature Difference [°C]					Temperature Difference [°C]					Temperature Difference [°C]									
		30	20	10	5		30	20	10	5		30	20	10	5		30	20	10	5	
LPH 40106	1450	0.04	0.06	0.10	0.14	0.03	0.06	0.09	0.16	0.25	0.6	0.07	0.10	0.18	0.29	0.7	-	-	-	-	-
	1750	0.06	0.08	0.12	0.16		0.08	0.11	0.19	0.29		0.09	0.13	0.22	0.33		0.12	0.17	0.29	0.45	1
LPH 40411	1450	0.07	0.09	0.13	0.18		0.10	0.14	0.23	0.33		0.12	0.16	0.27	0.39		-	-	-	-	-
	1750	0.09	0.11	0.16	0.19		0.13	0.18	0.27	0.38		0.15	0.20	0.31	0.43		0.20	0.27	0.42	0.59	1

Type	Speed [rpm]	Compression Pressure in [bar]																							
		0.6				0.8				1.2				1.5											
		KB				FB	KB				FB	KB				FB									
		Temperature Difference [°C]					Temperature Difference [°C]					Temperature Difference [°C]													
		30	20	10	5		30	20	10	5		30	20	10	5		30	20	10	5					
LPH 45008	1450	0.09	0.12	0.19	0.26	0.5	0.10	0.13	0.21	0.31	0.6	0.12	0.17	0.27	0.40	0.8	0.14	0.20	0.32	0.46	0.9				
	1750	0.11	0.15	0.22	0.30		0.13	0.17	0.26	0.35		0.16	0.21	0.33	0.46		0.18	0.24	0.37	0.52					
LPH 45316	1450	0.13	0.17	0.26	0.35		0.6	0.14	0.19	0.30		0.41	0.7	0.17	0.23		0.36	0.51	0.9	-		-	-	-	-
	1750	0.16	0.21	0.31	0.39			0.18	0.24	0.35		0.45		-	-		-	-		-		-	-	-	

FB = Operation with make-up water

KB = Combined make-up water with service liquid 30 °C, 20 °C, 10 °C, 5 °C warmer than make-up water.

Size Details - Ordering Information

Range + Size	Hydraulic and Bearings	Shaft Seal	Materials	Casing Sealing
	<ul style="list-style-type: none"> A• 1.Hydraulic •B Two greased roller bearings 	AGE Mechanical seal type SIHI FK, O-Rings Butadiene rubber AG1 Mechanical seal type SIHI FK, O-Rings Viton	0K Main parts out of cast iron (GG), impeller in low alloyed steel 4B Main parts out of stainless steel	1 O-Ring Sealing
LPH 40106 40411 45008 45316	AB	AGE, AG1	0K, 4B	1

other executions on request

SIHI LPH-X

Spare Parts Kits – Order Numbers

LPH 40106, LPH 40411

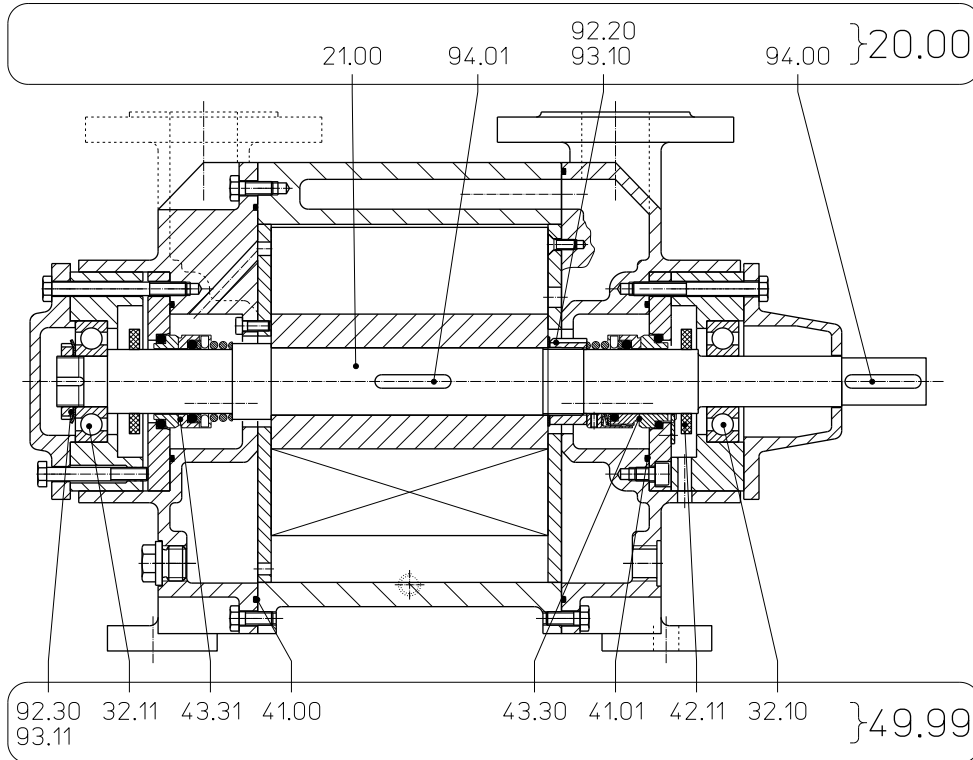

LPH 45008, LPH 45316

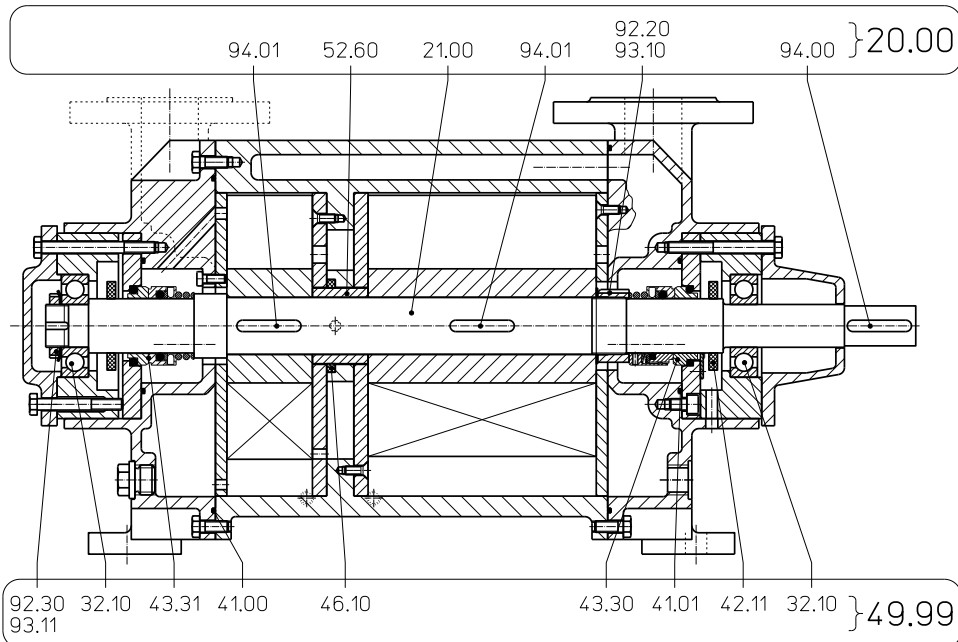

Material 0K					
Group	Spare Parts Kit	LPH 40106	LPH 40411	LPH 45008	LPH 45316
20.00	Shaft	65 006 715	65 006 714	65 006 712	65 006 710
49.99	Basic Repair AGE	65 008 221			

Material 4B					
Group	Spare Parts Kit	LPH 40106	LPH 40411	LPH 45008	LPH 45316
20.00	Shaft	65 006 754	65 006 755	65 006 757	65 006 759
49.99	Basic Repair AG1	65 008 223			

Accessories

Recommended Accessories	Material		LPH 40106	LPH 40411	LPH 45008	LPH 45316			
Liquid Separator		Type	XBd 0413						
		Weight	28 kg						
Separator	Steel, galvanised 1.4571	SIHI-Part No.	on request on request						
Service liquid line	Steel, galvanised 1.4571	SIHI-Part No.	20 059 389 20 059 393	20 059 390 20 059 394	20 059 391 20 059 395	20 059 392 20 059 396			
Pressure pipe (elbow)	1.0254 1.4571	SIHI-Part No.	35 003 165 35 003 166						
Liquid level indicator	Brass / Perspex 1.4571 / Perspex	SIHI-Part No.	43 014 920 43 040 384						
Liquid Drain		Type / Weight	XUk 1602 / 11 kg						
Service liquid drain	0.6020+ 1.454 1	SIHI-Part No.	43 014 792						
Gas balance line	Steel, galvanised 1.4571	SIHI-Part No.	on request 35 010 221						
Flange Adapter	Steel 1.4571	SIHI-Part No.	not required	20 059 826 on request	not required				
Drain Valve XCg 015	Steel 1.4571	SIHI-Part No.	on request 43 014 547						
Double nipple 1/2" - 1/4"	Steel, galvanised 1.4571	SIHI-Part No.	43 049 216 43 013 084						
Vent Valve	Brass 1.4571	SIHI-Part No.	43 014 257 43 014 271						
Motor									
Motor standard execution IP 55		Size Power Weight	100 L 3.0 kW 24 kg	112 M 4.0 kW 31 kg	132 S 5.5 kW 41 kg	132 S 5.5 kW 41 kg	132 M 7.5 kW 49 kg	160 M 11.0 kW 73 kg	
Coupling for motor IP 55		Type Weight	B 80 1.5 kg		B 95 2.6 kg	B 95 2.6 kg		B110 4.0 kg	
Pump side		SIHI-Part No.	43 021 414		43 021 426	43 021 426		43 021 439	
Motor side , incl. flexible elements		SIHI-Part No.	43 021 417		43 021 433	43 021 433		43 021 448	
Coupling guard	Steel	SIHI-Part No.	43 042 222		43 042 248	43 042 248		43 042 250	
Motor in EEx e II T3 execution		Size Power Weight	100 L 2.5 kW 23 kg	112 M 3.6 kW 29 kg	132 S 5.0 kW 42 kg	132 M 6.8 kW 61 kg	132 S 5.0 kW 42 kg	132 M 6.8 kW 61 kg	160 M 10.0 kW 67 kg
Coupling for motor EEx e II T3		Type Weight	BDS 88 2 kg		BDS 103 3 kg	BDS 103 3 kg		BDS 118 4 kg	
Pump side		SIHI-Part No.	43 111 058		43 111 051	43 111 051		43 111 042	
Motor side , incl. flexible elements		SIHI-Part No.	43 111 029		43 111 040	43 111 040		43 110 928	
Coupling guard	Brass	SIHI-Part No.	43 042 223		43 042 249	43 042 249		43 042 251	
Baseplate		Type Weight	S 301 27 kg		S 303 34 kg	S 303 34 kg		S 344 44 kg	S 385 62 kg
	Steel	SIHI-Part No.	43 040 634		43 040 635	43 040 635		43 040 637	43 040 639

Designs subject to change without prior notice.