

# SIHI<sup>LPH-X</sup> - Liquid Ring Vacuum Pump

One Stage

LPH 60527



SIHI® Pumps

**Pressure Range:** 120 to 1013 mbar  
**Suction Range:** 200 to 800 m<sup>3</sup>/h

## CONSTRUCTION

Sterling SIHI liquid ring vacuum pumps have a simple but robust construction with the following features and benefits:

- Near isothermal compression
- Oil free, with no internal lubrication
- Capable of handling almost all gases and vapours
- Able to handle quantities of liquid "carry over"
- Low maintenance and safe operation
- Low noise and almost vibration free
- Available in a wide range of materials
- Broad range of applications
- O-ring sealing as standard
- Cavitation protection as standard
- Drain hole as standard
- Built-in solids drain
- Rotating metallic parts are non contacting to minimise wear
- ATEX compliance

Sterling SIHI liquid ring vacuum pumps of the range LPH 60527 are one stage pumps. They can be used as compressors up to a pressure of 1.5 bar without any modification (see the Technical Catalogue - Liquid Ring Compressors Part K).

## APPLICATIONS

Evacuation and pumping of dry gases and saturated vapours. The pumps can also handle liquids. These units offer pressures in the range of 120...900 mbar(a) to atmospheric. Typical application areas include:

- Chemical and pharmaceutical industry for distillation, drying and degassing.
- Electronic industry for impregnation and drying.
- Plastics & Rubber industry for degassing.



## NOTE

By continuously feeding the pump with a small amount of service liquid (usually water), the heat due to gas/vapour compression is conducted away. This also replenishes the liquid ring and ensures that it does not become saturated with process media. The condensed gas and fluid can be separated in a liquid separator (see Accessories Catalogue). Recharging the pump with service liquid at ambient temperature enables the unit to condense evacuated gases/vapours. It can therefore be used for solvent recovery. More information is provided in the accessory catalogues. The integrated solids drain permits the removal of any entrained solids whilst the pump is operating. The service liquid can, therefore, simply be re-circulated. The rotation of the pump is clockwise when viewed from the drive end.

## GENERAL TECHNICAL DATA

Pump Type	Units	LPH 60527
Speed	50 Hz 60 Hz	rpm 1450 1740
Maximum overpressure on compression	bar	1.2
Permissible pressure difference between suction and discharge side	max. min.	1.5 0.2
Hydraulic test pressure (overpressure)	bar	3.0
Moment of inertia of rotating parts of pump and water content	kg · m <sup>2</sup>	0.36
Noise level at 200 mbar suction pressure	dB (A)	76
Minimum permissible pulley diameter for V belt drive	mm	200
Max. Gas temperature:	dry saturated	°C °C 200 100
Service liquid:		
Maximum permissible temperature	°C	80
Minimum permissible temperature	°C	10
Maximum viscosity	mm <sup>2</sup> /s	90
Maximum density	kg/m <sup>3</sup>	1200
Liquid capacity up to middle of shaft	litre	14.0
Maximum flow resistance of the heat exchanger	bar	0.2

In selecting a pump, avoid choosing one which is likely to be operating at a combination of its maximum permissible limits e.g. maximum viscosity and maximum permissible pressure difference.

## Materials

Position number	Component	Materials	
		0B	4B
10.10	Vacuum casing	0.6025	1.4408
10.90	Central body		
13.70	Guide disc		1.4404
21.00	Shaft	1.4021	1.4517
23.50	Impeller	1.0553	1.4517
43.30, 43.31	Mechanical seal, Type SIHI FK (AG*)	Cr-Steel / Carbon / Butadiene rubber	Cr Ni Mo-Steel / Carbon / Viton
43.30, 43.31	Double mechanical seal	on request	
46.10	Gland packing	GORE	-

Cut-away diagram LPH 60527 with single, double mechanical seal and gland packing

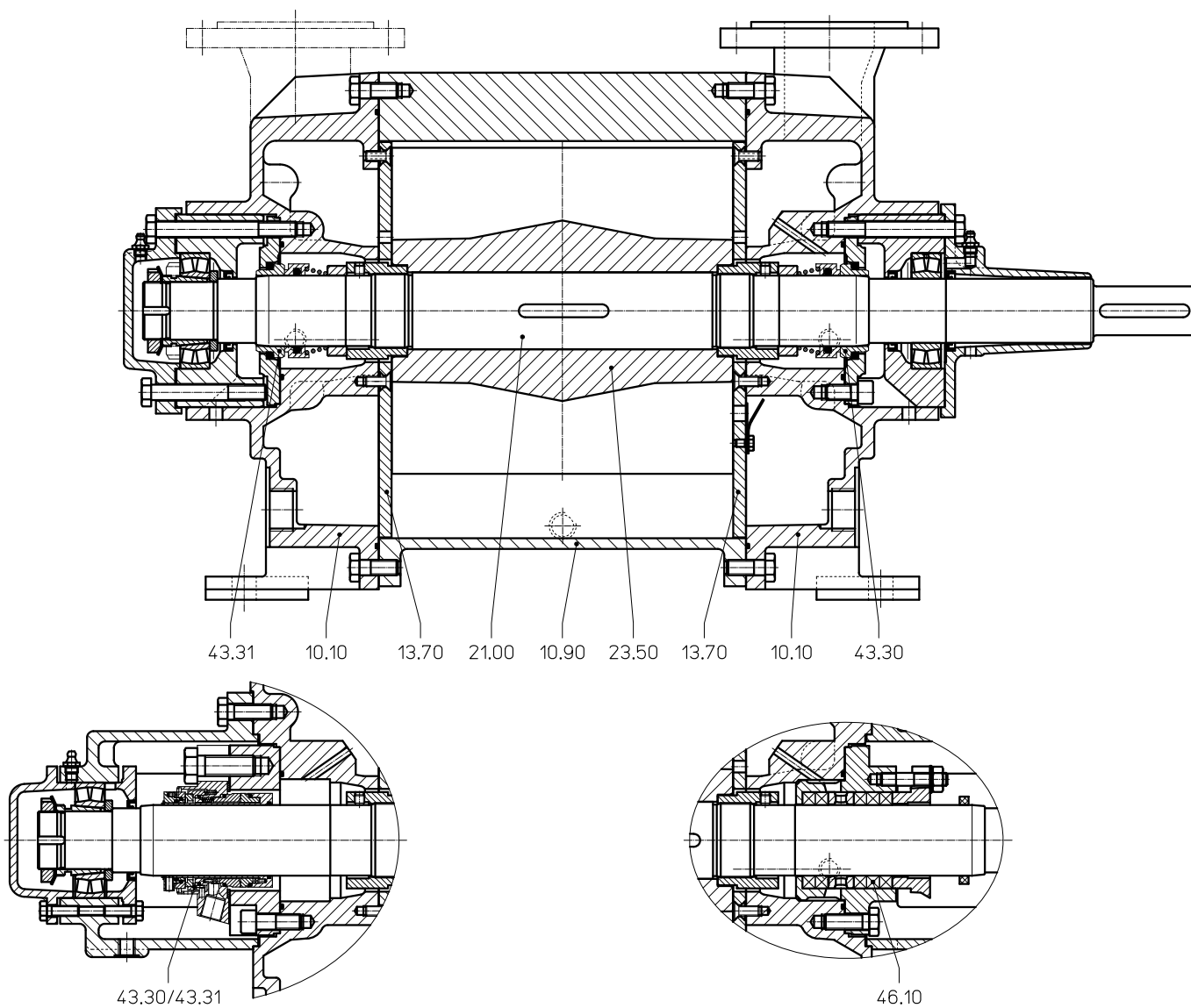

Performance Characteristics LPH 60527

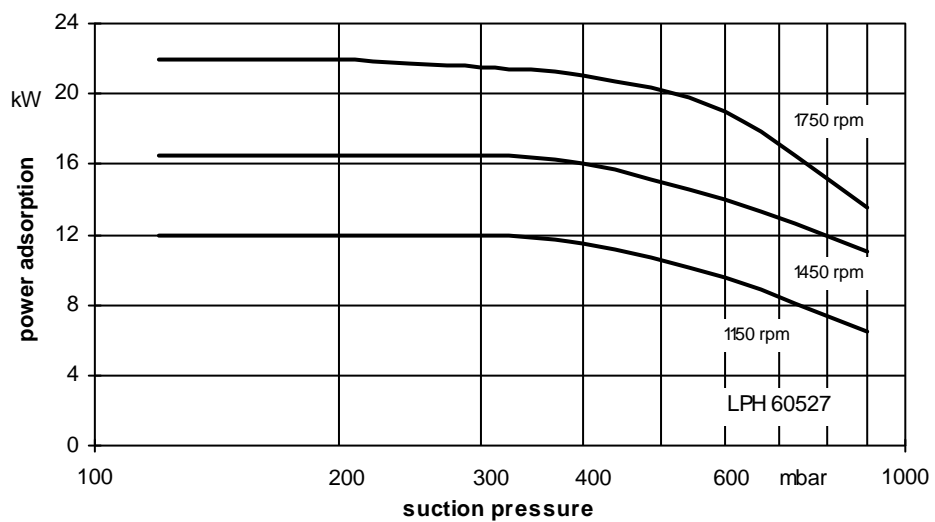
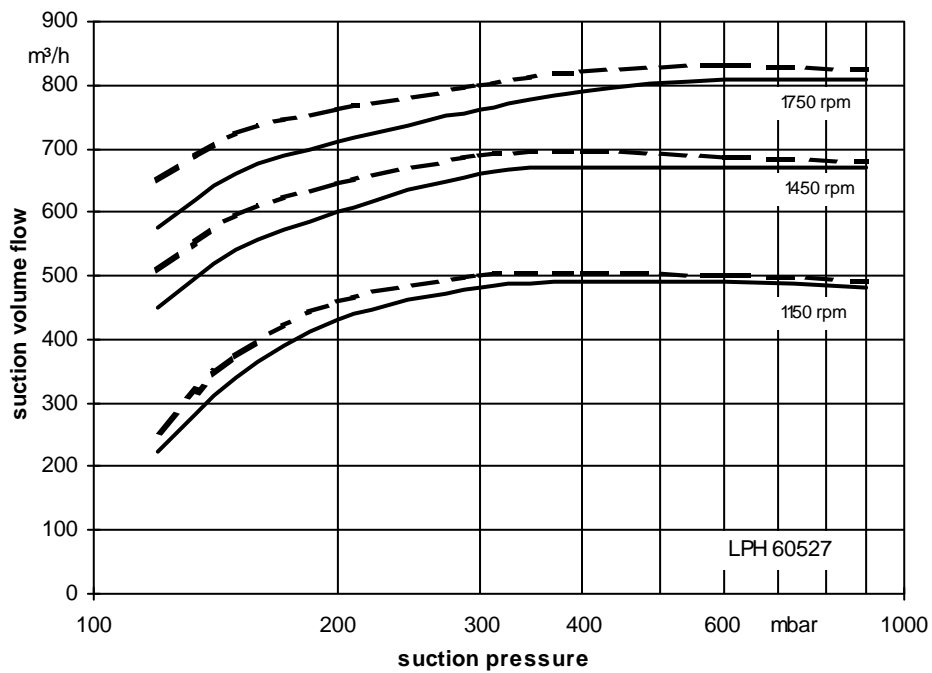

The operating data is valid under the following conditions:

- Process media:
  - dry air: 20°C —————
  - steam saturated air: 20°C - - - - -
- Service liquid:
  - water: 15°C

Pressure of gas to be evacuated: 1013 mbar (Atmospheric pressure)

The suction volume is related to the suction pressure.

Tolerance for the suction volume flow is 10% and for power 5%.

The maximum consumption of make up water occurs at the lowest suction pressure.

# SIHI<sup>LPH-X</sup>

## Dimensions LPH 60527 with single mechanical seal and gland packing

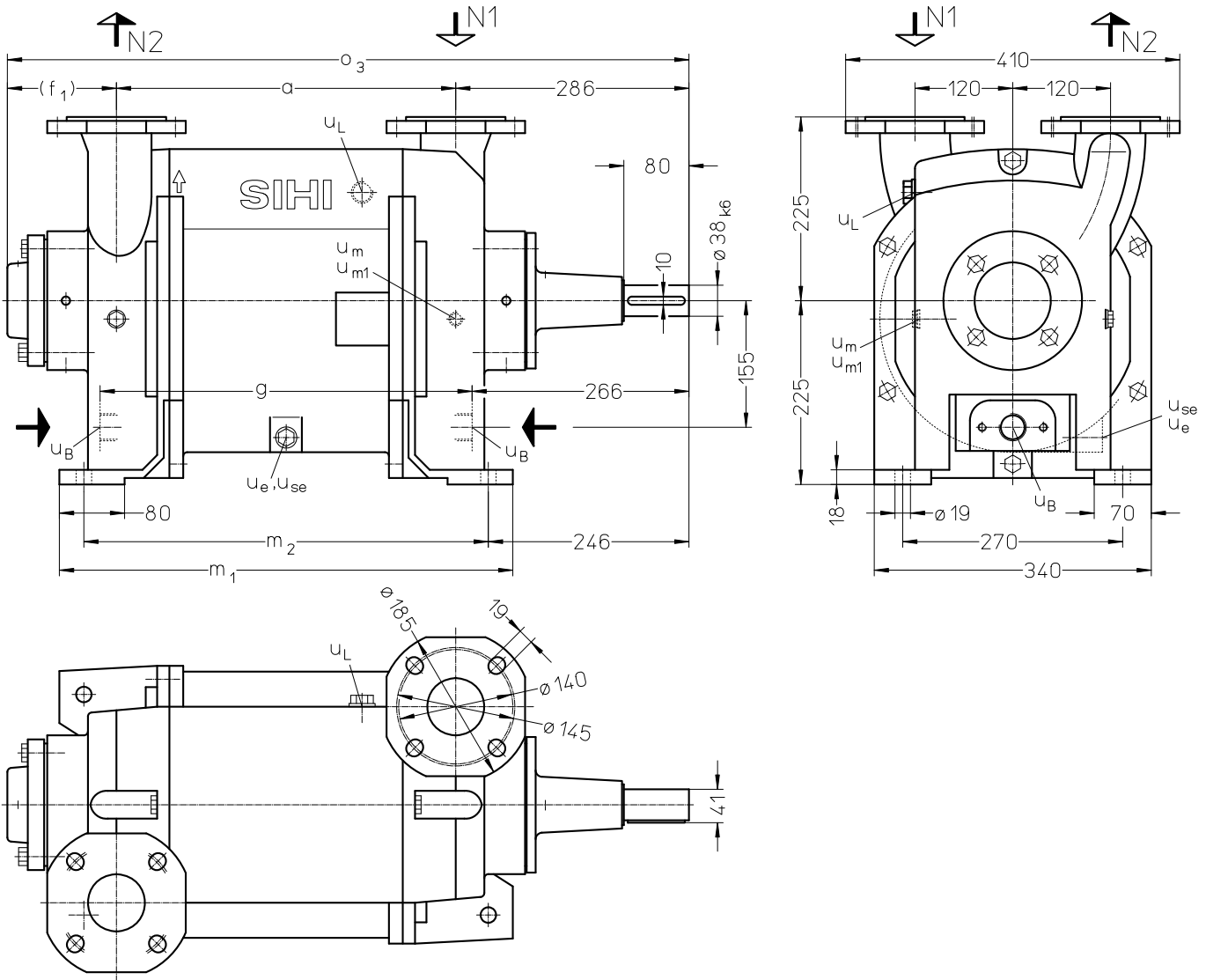

N 1 = Gas-inlet DN 65 (according to DIN 2501 PN 10)  
 Gas-inlet 2 1/2" (according to ANSI 150 lbs)

N 2 = Gas-outlet DN 65 (according to DIN 2501 PN 10)  
 Gas-outlet 2 1/2" (according to ANSI 150 lbs)

$u_B$  = Connection for service liquid G 1

$u_e$  = Connection for drain G 1/2

$u_{se}$  = Connection for dirt drain G 1/2

$u_L$  = Connection for air cock G 3/4

$u_m$  = Connection for pressure gauge G 3/8 (Grey cast iron)  
 Connection for pressure gauge G 3/4 (Stainless steel)

$u_{m1}$  = Connection for drainage valve or liquid level sensor G 3/8 (Grey cast iron)  
 Connection for drainage valve or liquid level sensor G 3/4 (Stainless steel)

	Execution	a [mm]	f <sub>1</sub> [mm]	g [mm]	m <sub>1</sub> [mm]	m <sub>2</sub> [mm]	o <sub>3</sub> [mm]	approx. weight [kg]
LPH 60527	Mechanical seal	416	134	456	556	496	902	180
	Gland packing		223				991	

## LPH 60527 with single mechanical seal, gland packing and top-mounted liquid separator

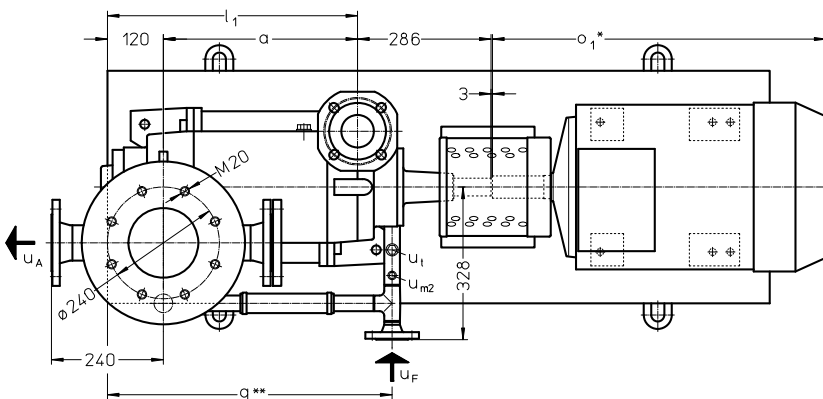
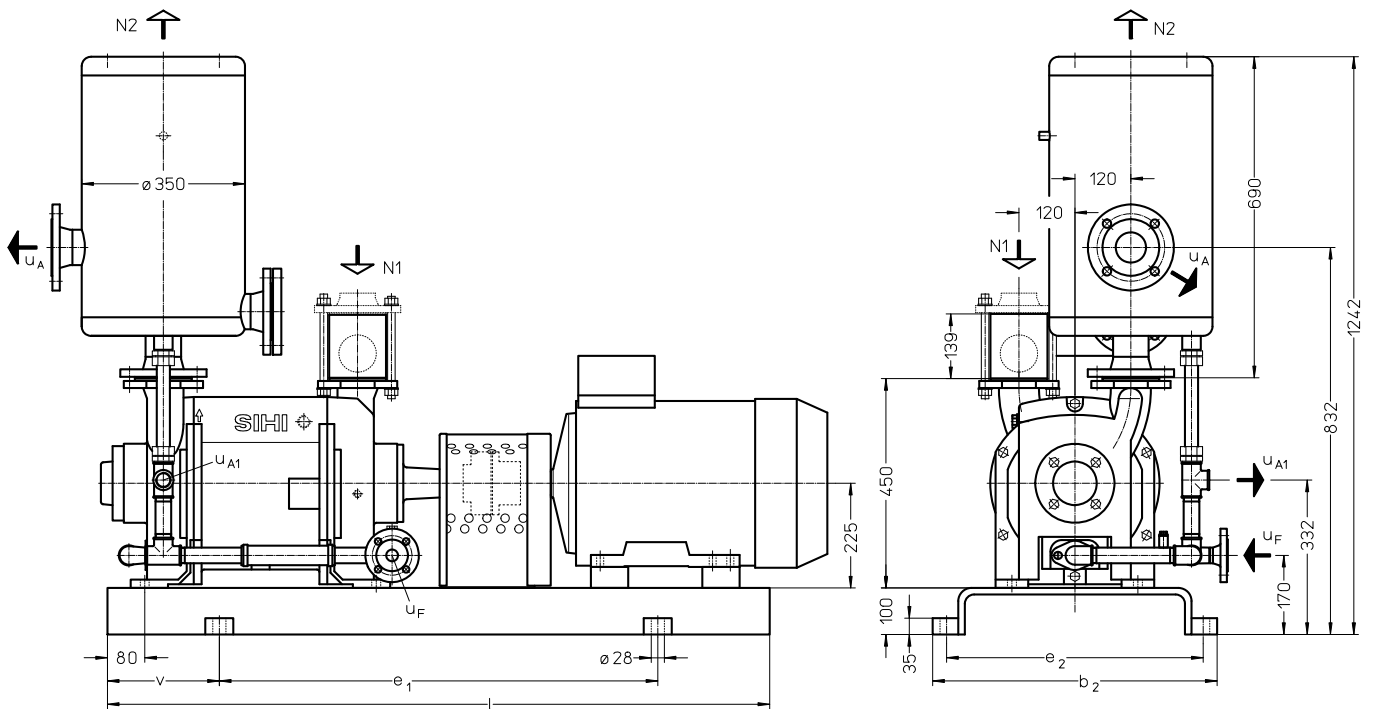

- N 1 = Gas-inlet DN 65
- N 2 = Gas-outlet DN 150
- u<sub>A</sub> = Liquid drain DN 65
- u<sub>A1</sub> = Liquid drain G 1
- u<sub>F</sub> = Connection for make up water DN 25
- u<sub>m2</sub> = Connection for pressure gauge G 1/4
- u<sub>t</sub> = Connection for thermometer G 1/2

	E-Motor 50 Hz			base-plate	a [mm]	b <sub>2</sub> [mm]	e <sub>1</sub> [mm]	e <sub>2</sub> [mm]	l [mm]	l <sub>1</sub> [mm]	o <sub>1</sub> * [mm]	q** [mm]	v [mm]	approx. weight [kg]
	size	IP 55	kW											
LPH 60527	180 M	18.5	-	S487	416	610	940	550	1420	536	715	610	240	529
	180 L	-	17.5											

\* Dimensions dependent upon motor supplier

\*\* Dimension +15mm with service liquid line in stainless steel

Flange dimensions according to DIN 2501 PN 10 [mm]		
DN	25	65
k	85	145
D	115	185
Number x d <sub>2</sub>	4 x 14	4 x 18

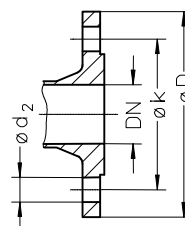

## LPH 60527 with single mechanical seal, gland packing and side-mounted liquid separator

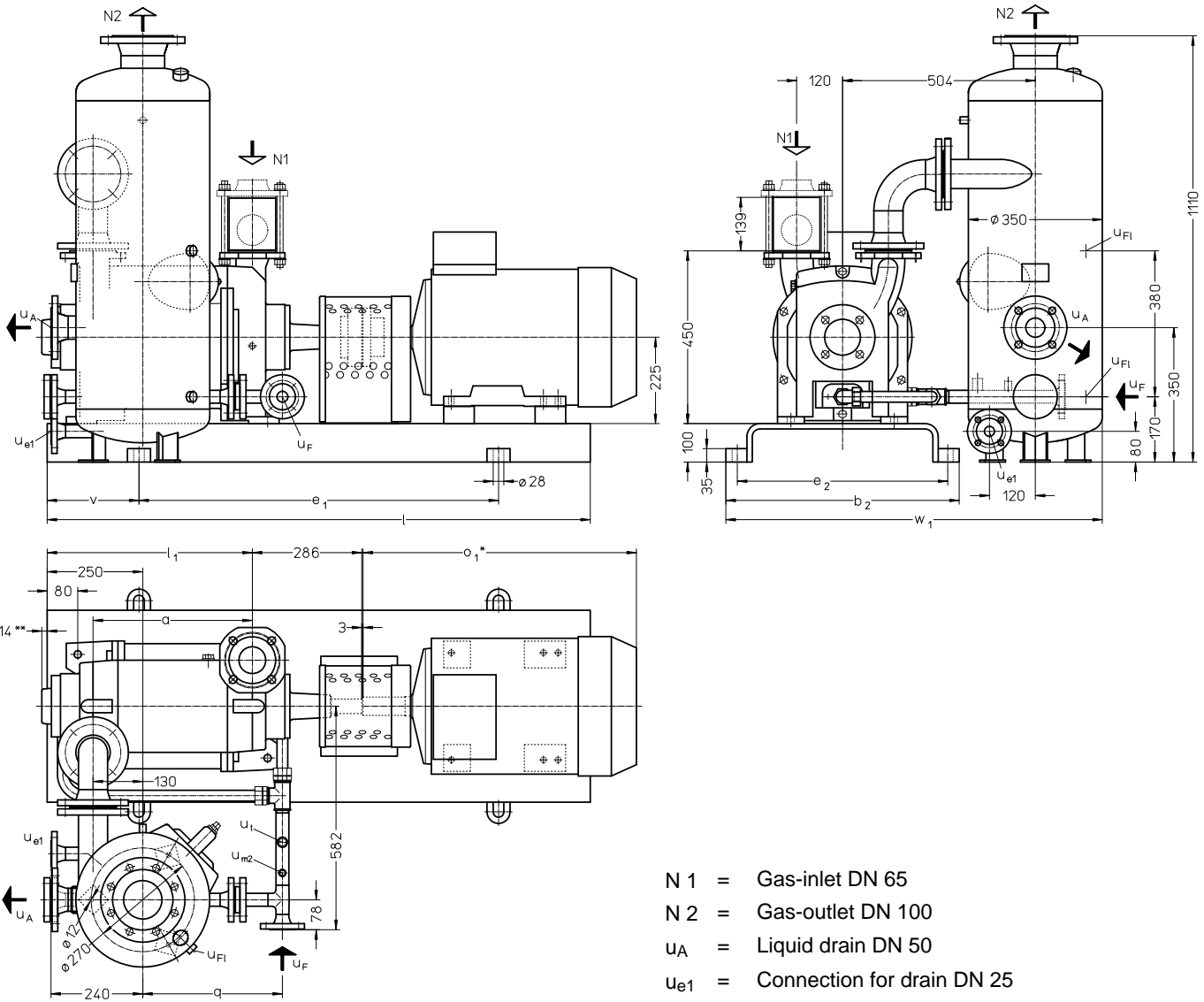

- N 1 = Gas-inlet DN 65
- N 2 = Gas-outlet DN 100
- U<sub>A</sub> = Liquid drain DN 50
- U<sub>e1</sub> = Connection for drain DN 25
- U<sub>F</sub> = Connection for make up water DN 25
- U<sub>Fl</sub> = Connection for liquid level indicator G 1/2
- U<sub>m2</sub> = Connection for pressure gauge G 1/4
- U<sub>t</sub> = Connection for thermometer G 1/2

	E-Motor 50 Hz		base-plate	a [mm]	b <sub>2</sub> [mm]	e <sub>1</sub> [mm]	e <sub>2</sub> [mm]	l [mm]	l <sub>1</sub> [mm]	o <sub>1</sub> * [mm]	q [mm]	v [mm]	w <sub>1</sub> [mm]	approx. weight [kg]	
	size	kW													IP 55
LPH 60527	180 M	18.5	-	S487	416	610	940	550	1420	536	715	365	240	984	551
	180 L	-	17.5												

\* Dimensions dependent upon motor supplier  
 \*\* Dimension +89mm at execution with gland packing

Flange dimensions according to DIN 2501 PN 10 [mm]				
DN	25	50	65	100
k	85	125	145	180
D	115	165	185	220
Number x d <sub>2</sub>	4 x 14	4 x 18	4 x 18	8 x 18

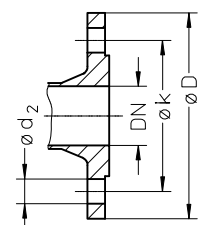

**Make-up Liquid Consumption** in [m<sup>3</sup>/h] dependent upon suction pressure, speed, drive type and temperature difference.

Suction Pressure in [mbar]		120				400				600				900							
Pump type	Speed [rpm]	KB				FB	KB				FB	KB				FB					
		Temperature Difference °C					Temperature Difference °C					Temperature Difference °C									
		20	10	5	2		20	10	5	2		20	10	5	2		20	10	5	2	
LPH 60527	1150	0.45	0.81	1.34	2.19	3.8	0.42	0.72	1.14	1.75	2.7	0.33	0.56	0.86	1.25	1.8	0.18	0.26	0.35	0.42	0.5
	1450	0.60	1.03	1.62	2.47		0.55	0.91	1.36	1.94		0.45	0.72	1.03	1.39		0.24	0.33	0.40	0.45	
	1750	0.76	1.26	1.90	2.71		0.68	1.08	1.54	2.08		0.56	0.86	1.16	1.47		0.27	0.35	0.41	0.46	

FB = Total service liquid flow rate on once-through system

KB = Flow of makeup water when combined with partial recirculation liquid at a temperature of 20°C, 10°C, 5°C, 2°C warmer than make-up water.

## Product Code - order details

Range + Size	Hydraulic + Bearings	Shaft Seal	Materials	Casing Sealing
	<ul style="list-style-type: none"> <li>•A 1. Hydraulic</li> <li>•B Two greased roller bearings</li> </ul>	041 Gland packing AGE Mechanical seal type SIHI FK, O-rings butadiene rubber AG1 Mechanical seal type SIHI FK, O-rings Viton	0B Main parts out of cast iron (GG), impeller in steel 4B Main parts out of stainless steel	1 O-ring sealing
LPH 60527	AB	041, AGE	0B	1
		AG1	4B	

## Motor Selection

For our products we offer a lot of different motor types.

To identify the right motor please specify frequency, voltage and protection class.

## Example of an Order:

LPHX 60527 AB AGE 0B 1 with 18.5 kW AC motor, 50 Hz, 400V Δ, IP55

# SIHI<sup>LPH-X</sup>

## Spare Parts Order Number

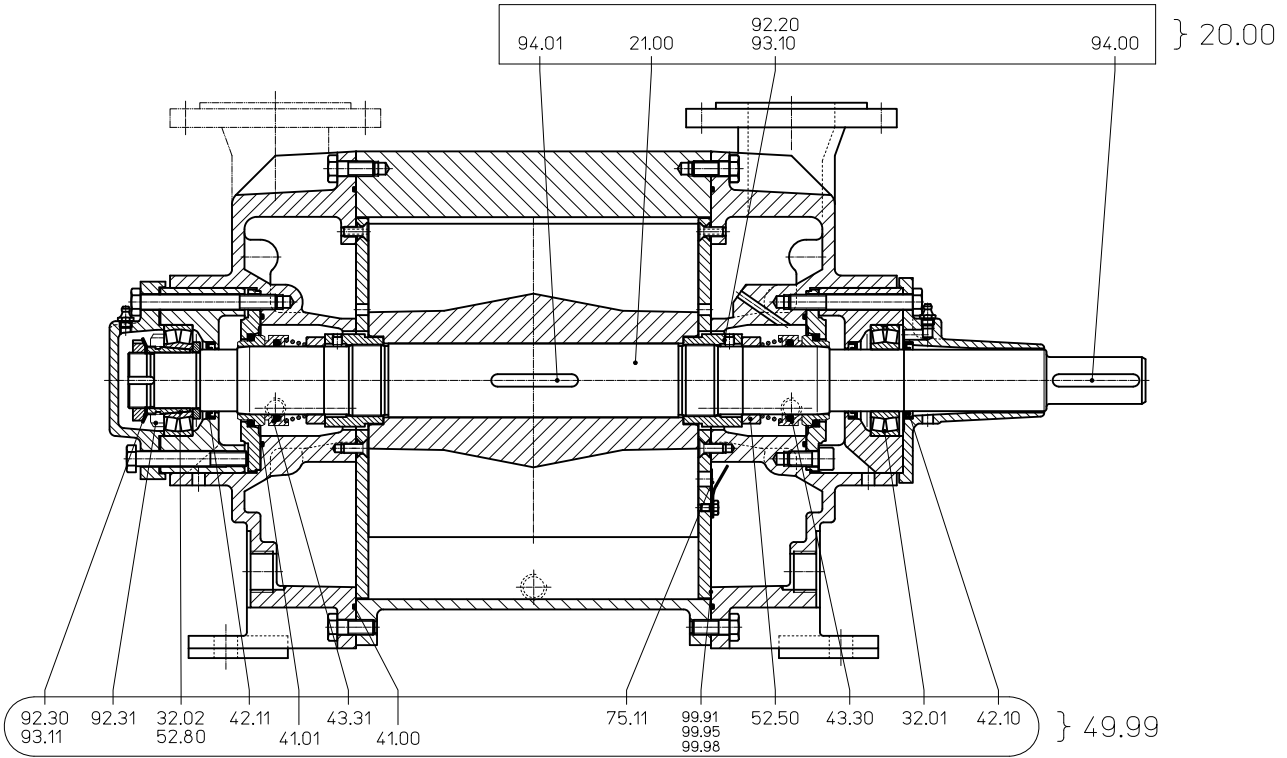

Material Design 0B		
Group	Spare parts kit	
20.00	Shaft	65 007 893
49.99	Basic repair AGE	65 007 772

Material Design 4B		
Group	Spare parts kit	
20.00	Shaft	65 007 898
49.99	Basic repair AG1	65 007 886

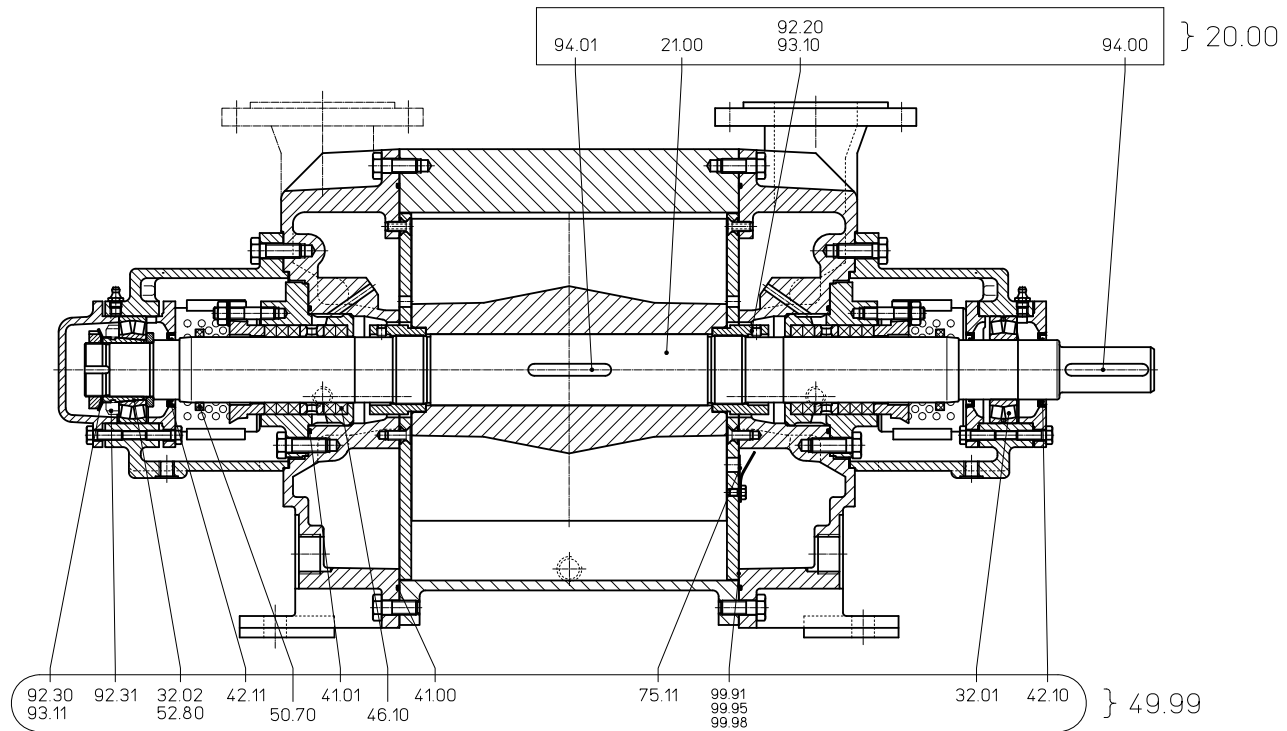

Material Design 0B		
Group	Spare parts kit	
20.00	Shaft	65 007 899
49.99	Basic repair 041	65 007 897



**Accessories**

Recommended Accessory	Material Execution		LPH 60527
<b>Top Mounted Liquid Separator</b>		Type / Weight	XBa 5540 / 35 kg
Top mounted separator	Steel, galvanised 1.4571	SIHI-Part No.	43 134 149 43 132 195
Service liquid pipework, standard execution	Steel 1.4571	SIHI-Part No.	35 003 125 35 003 126
Service liquid pipework with thermostatic control	Steel + Brass 1.4571 + Brass	SIHI-Part No.	20 073 168 20 073 219
<b>Side Mounted Liquid Separator</b>		Type / Weight	XBp 912 / 51 kg
Side mounted separator	Steel, galvanised 1.4571	SIHI-Part No.	43 132 197 43 132 198
Service liquid pipework, standard execution	Steel 1.4571	SIHI-Part No.	35 028 990 35 028 991
Service liquid pipework with thermostatic control	Steel + Brass 1.4571 + Brass	SIHI-Part No.	20 073 285 20 073 286
Pressure pipework (bend)	1.0254 1.4571	SIHI-Part No.	35 003 224 35 003 226
Liquid level indicator	Brass + Plexiglas 1.4571 + Plexiglas	SIHI-Part No.	43 014 912 43 040 384
<b>Sterling SIHI - Non Return Ball Valve</b>			
Intermediate flange execution XCk 65	0.6025 + Butadiene rubber 0.6025 + Teflon 1.4408 + Teflon	SIHI-Part No. Weight	20 072 794 / 5.6 kg 20 072 793 / 5.6 kg 20 029 500 / 15.8 kg
Flange execution with glass cylinder XCk 656	0.6025 + Butadiene rubber 0.6025 + Teflon 1.4408 + Teflon	SIHI-Part No. Weight	20 072 851 / 10.0 kg 20 072 852 / 10.0 kg 20 072 850 / 10.0 kg
<b>Adapter Flange</b>	Steel 1.4571	SIHI-Part No.	43 076 094 + 43 076 095 43 078 489 + 43 078 490
<b>Drain Valve + Double nipple</b>			
XCg 015 XCg 015	Steel 1.4571	SIHI-Part No.	43 014 545 + 43 013 086 43 014 547 + 43 013 097
<b>Air Inlet Valve + Double nipple</b>	Brass 1.4408	SIHI-Part No.	43 045 945 + 43 013 090 43 053 736 + 43 013 091
<b>Motor</b> standard execution IP 55		Size Power Weight	180 M 18.5 kW 113 kg
Coupling for motor IP 55 Pump side Motor side		Type / Weight SIHI-Part No.	B 125 / 6.2 kg 43 021 460 43 021 462
Coupling guard <sup>1)</sup> Coupling guard <sup>2)</sup>	Steel Steel	SIHI-Part No. SIHI-Part No.	43 042 306 43 042 304
<b>Motor</b> in EEx e II T3 execution		Size Power Weight	180 L 17.5 kW 177 kg
Coupling for motor EEx e II T3 Pump side Motor side		Type / Weight SIHI-Part No.	BDS 135 / 6.6 kg 43 111 062 43 090 912
Coupling guard <sup>1)</sup> Coupling guard <sup>2)</sup>	Brass Brass	SIHI-Part No. SIHI-Part No.	43 042 307 43 042 305
<b>Baseplate</b>	Steel	Type / Weight SIHI-Part No.	S 487 / 105 kg 43 040 642

<sup>1)</sup> execution with mechanical seal

<sup>2)</sup> execution with gland packing

Designs subject to change without prior notice.

**Sterling SIHI GmbH**

Lindenstraße 170, D-25524 Itzehoe, Germany, Tel. +49 (0) 48 21 / 7 71 - 01, Fax +49 (0) 48 21 / 7 71-274