

LEH 1200, LEH 1500, LEH 1800

Pressure range: 33 to 1013 mbar
Suction volume flow: 440 to 2050 m³/h

CONSTRUCTION TYPE

SIHI liquid ring vacuum pumps are displacement pumps of uncomplicated and robust construction with the following particular features:

- non-polluting due to nearly isothermal compression
- oil-free, as no lubrication in the working chamber
- handling of nearly all gases and vapours
- small quantities of entrained liquid can be handled
- easy maintenance and reliable operation
- low noise and nearly free from vibration
- wide choice of material, therefore applicable nearly everywhere
- Internal service liquid return; adjustable from the outside
- protection against cavitation as standard
- incorporated dirt drain
- incorporated central drain
- no metallic contact of the rotating parts

The SIHI liquid ring vacuum pumps LEH are single-stage ones.

APPLICATION

Handling and exhausting of dry and humid gases; entrained liquid can be handled during normal duty. The pumps are applied in all fields where a pressure of 33 to 900 mbar must be created by robust vacuum pumps.

Fields of application are for example:

- chemistry and pharmacy for distilling and degassing,
- electric industry for impregnation and drying
- plastics industry for degassing etc.



NOTE

During operation the pump must continuously be supplied with service liquid, normally water, in order to eliminate the heat resulting from the gas compression and to replenish the liquid ring, because part of the liquid is leaving the pump together with the gas. This liquid can be separated from the gas in a liquid separator (see catalogue part accessories).

It is possible to reuse the service liquid. The pumps are equipped with a device by which the contaminated service liquid can continuously be drained during operation (dirt drain), if necessary.

The direction of rotation is clockwise, when looking from the drive on the pump.

GENERAL TECHNICAL DATA

Pump type	unit	LEH 1200	LEH 1500	LEH 1800
Speed	50 Hz 60 Hz		975 1175	
Max. compression over pressure	bar	1,5		1,2
Max. admissible pressure difference	bar	1,5		1,2
Hydraulic test (over pressure)	bar		3	
Moment of inertial of the rotating pump parts and of the water filling	kg · m ²	2,6	3,05	3,5
Sound pressure level at a suction pressure of 80 mbar	dB (A)		79	
Min. pulley diameter permissible in case of V-belt drive	mm	355		500
Max. gas temperature	dry saturated		200 100	
Service liquid				
max. admissible temperature	°C		80	
max. viscosity	mm ² /s		90	
max. density	kg/m ³		1200	
volume up to shaft level	liter	30	35	39,5
Max. flow resistance of the heat exchanger	bar		0,2	

The combination of several limiting values is not admissible.

Material design

Item.	COMPONENTS	MATERIAL DESIGN	
		0B	4B
10.60, 10.70	Casing	0.6025	1.4408
10.90	Central body	1.0553	1.4571
13.70, 13.71	Guide disk	0.6025	1.4408
21.00	Shaft	1.0503	
23.50	Vane wheel impeller	0.7043	1.4517
43.30, 43.31	Standard mechanical seal	Cr-steel / carbon / Perbunan	Cr Ni Mo-steel / carbon / Viton
46.10	Gland packing	Soft packing	
52.40	Shaft sleeve	1.4027.05	1.4571

Sectional drawing LEH 1200, LEH 1500, LEH 1800

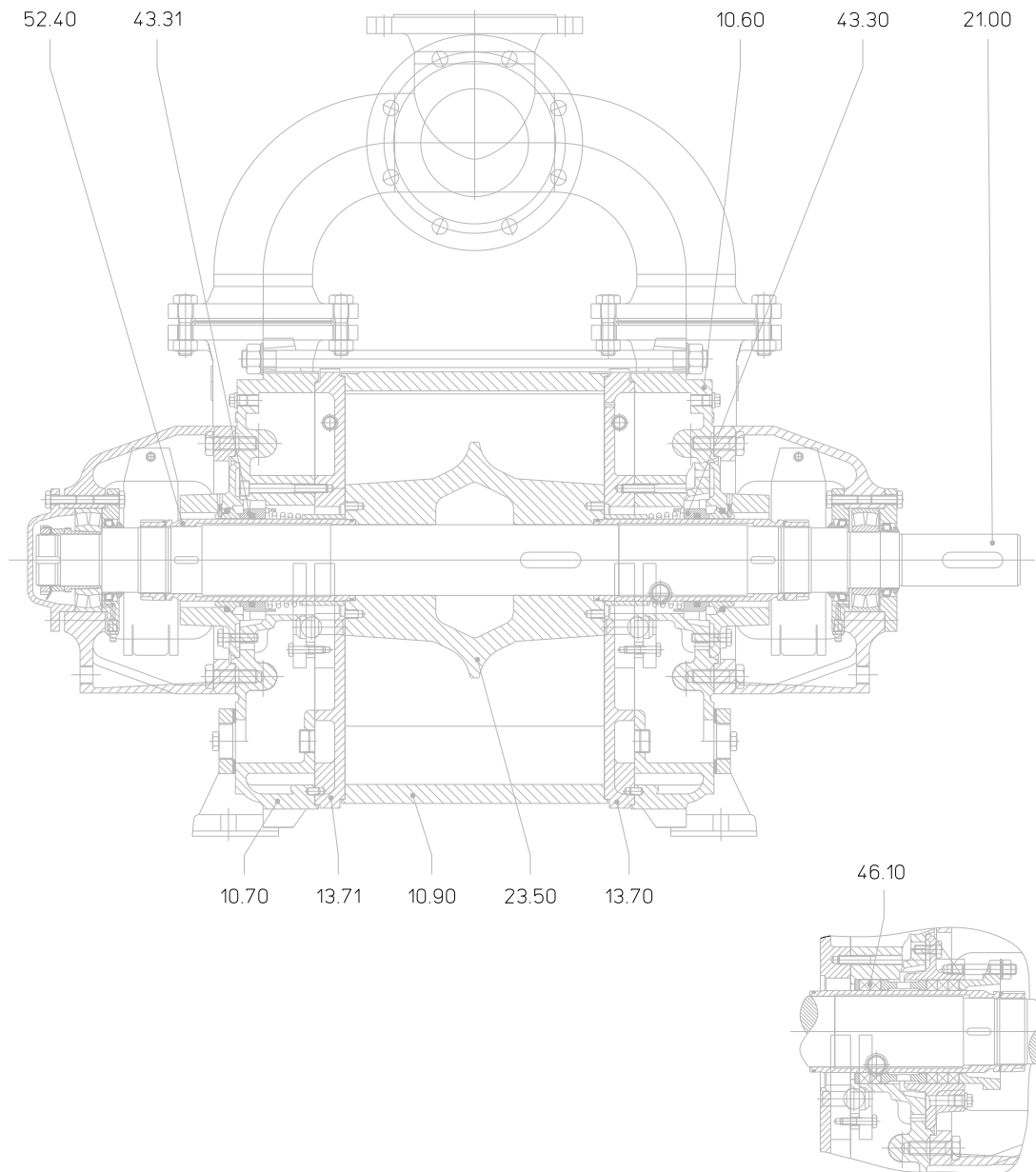

Suction volume flow and power absorption LEH 1200

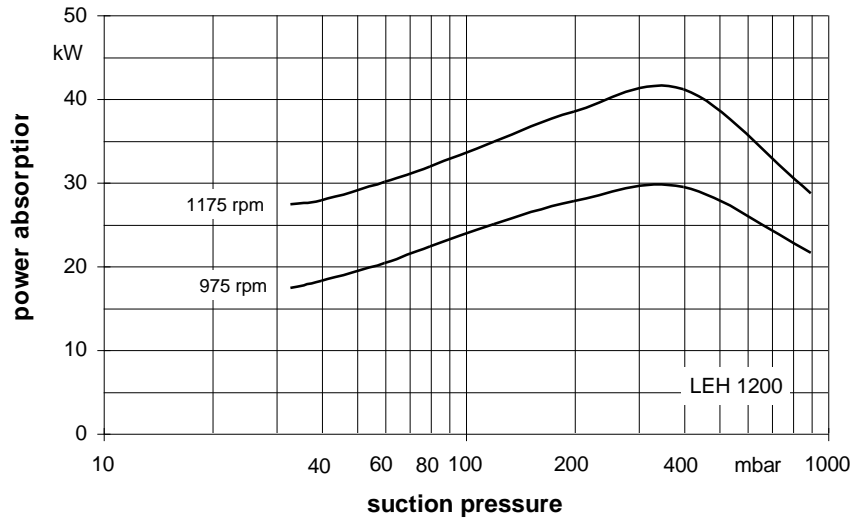
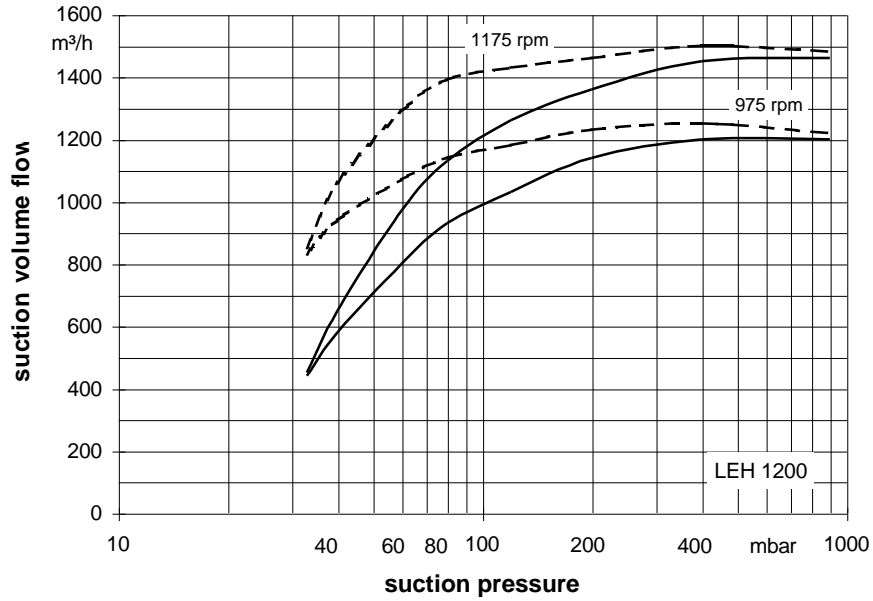

The operating data are applicable under the following conditions:

- pumping medium:
 - dry air: 20°C —————
 - water vapour saturated air: 20°C - - - - -
- service liquid:
 - water: 15°C

Compression pressure 1013 mbar (atmospheric pressure)
 The suction volume flow is applied to the suction pressure
 Tolerance of the operating data 10%
 Max. fresh water need with lowest suction pressure

Suction volume flow and power absorption LEH 1500

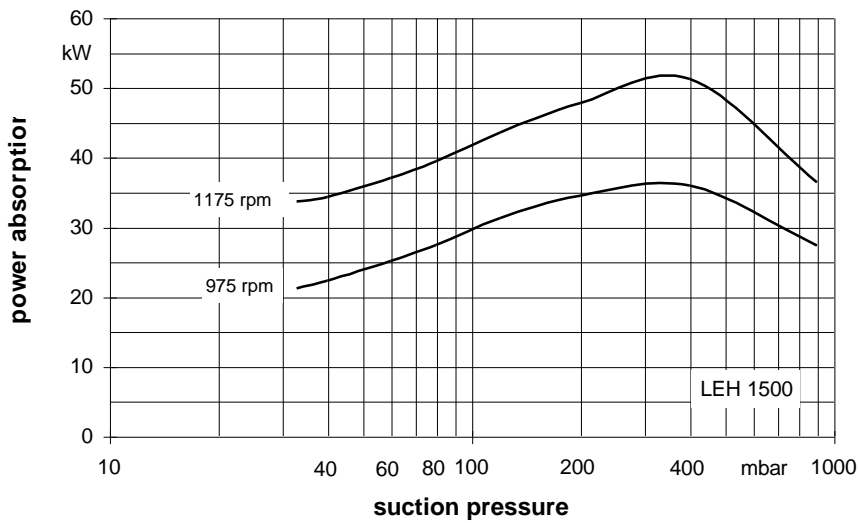
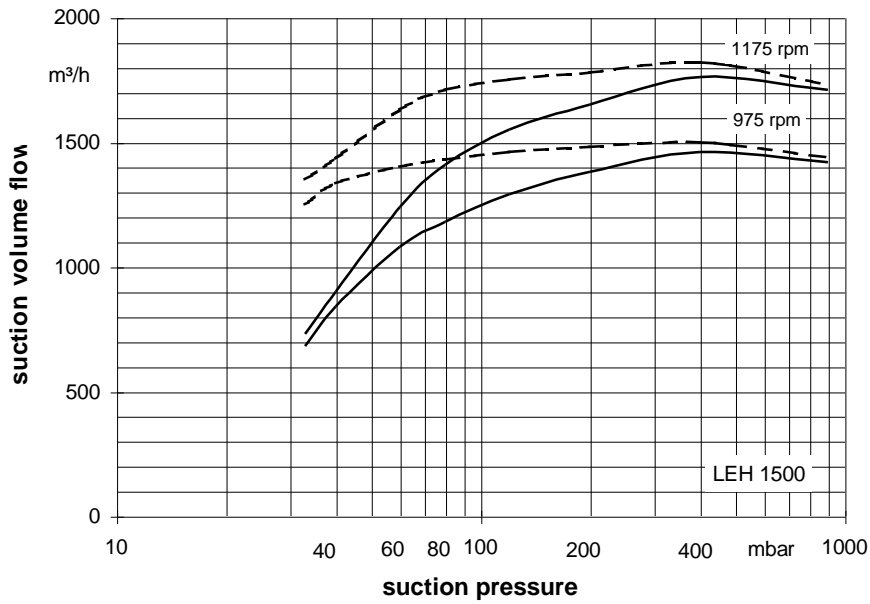

The operating data are applicable under the following conditions:

- pumping medium:
 - dry air: 20°C _____
 - water vapour saturated air: 20°C - - - - -
- service liquid:
 - water: 15°C

Compression pressure 1013 mbar (atmospheric pressure)

The suction volume flow is applied to the suction pressure

Tolerance of the operating data 10%

Max. fresh water need with lowest suction pressure

Suction volume and power absorption LEH 1800

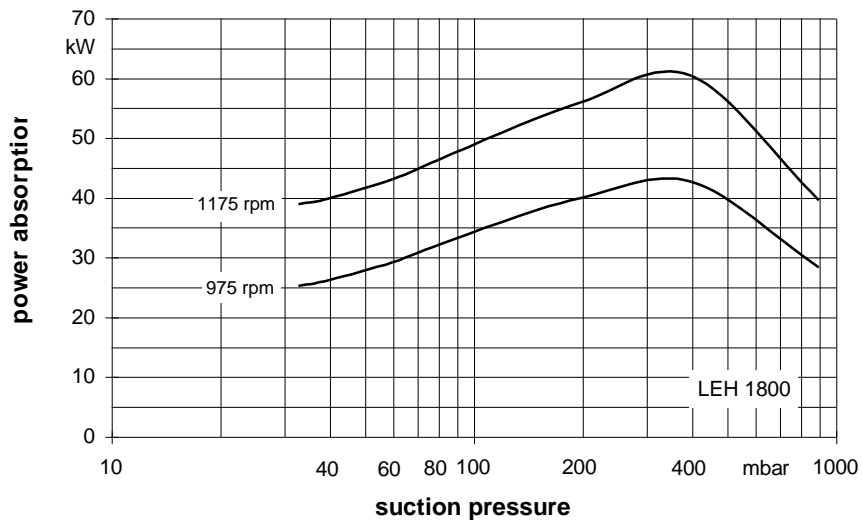
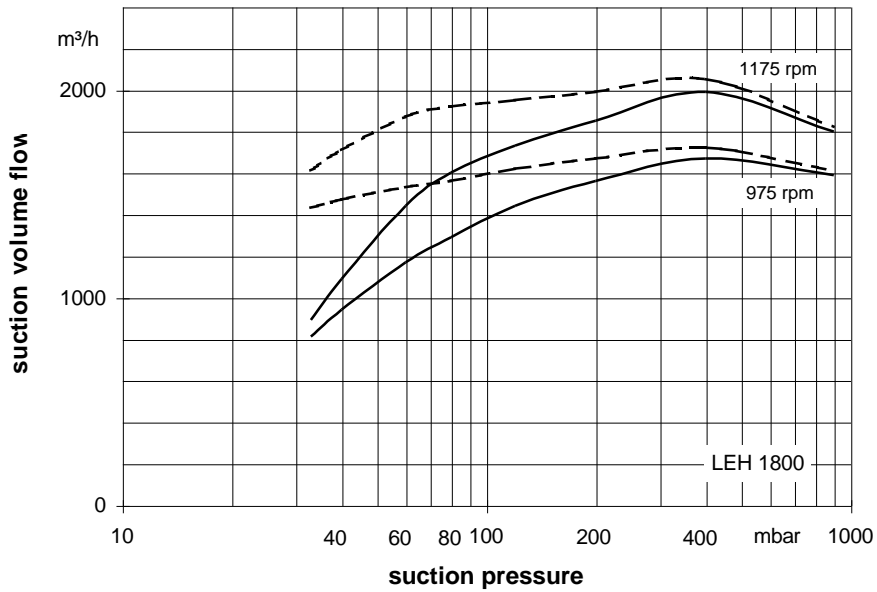

The operating data are applicable under the following conditions:

- pumping medium:
 - dry air: 20°C —————
 - water vapour saturated air: 20°C - - - - -
- service liquid:
 - water: 15°C

Compression pressure 1013 mbar (atmospheric pressure)

The suction volume flow is applied to the suction pressure

Tolerance of the operating data 10%

Max. fresh water need with lowest suction pressure

Dimension table LEH 1200, LEH 1500, LEH 1800

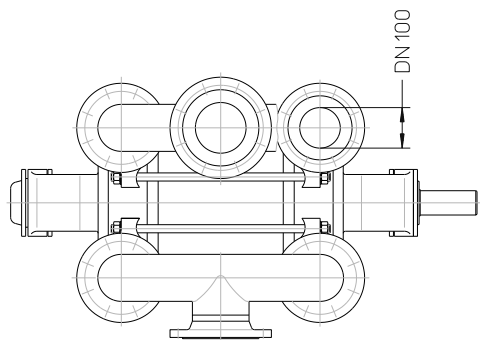
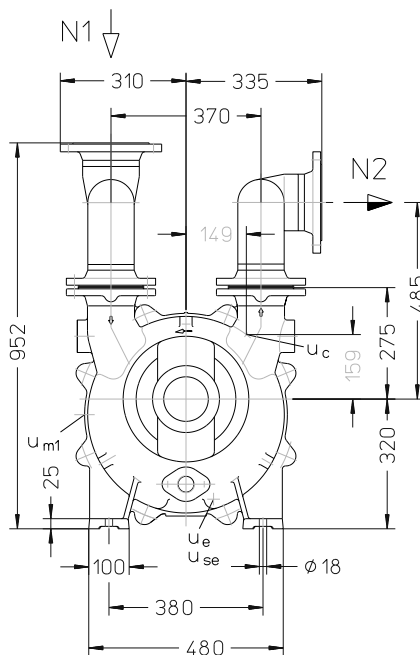
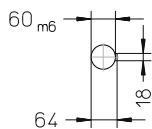
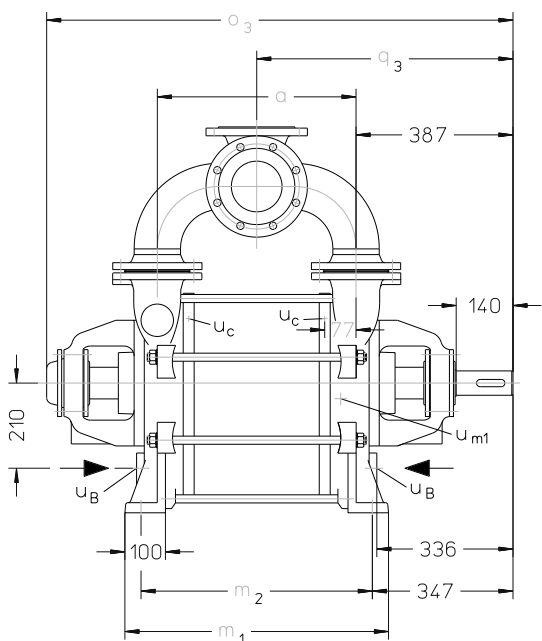

	a	m ₁	m ₂	o ₃	q ₃	weight app. kg
LEH 1200	490	651	571	1150	632	479
LEH 1500	560	721	641	1220	667	519
LEH 1800	615	776	696	1275	695	549

- N 1 = gas inlet DN 125
- N 2 = gas outlet DN 125
- u_B = connection for service liquid G 1 ¼
- u_c = connection for protection against cavitation G ¼
- u_e = drain connection G ½
- u_{m1} = connection for drain valve G ½
- u_{se} = connection for dirt drain G ½

flange connections to DIN 2501 PN 10		
DN	100	125
k	180	210
D	220	250
number x d ₂	8 x 18	8 x 18

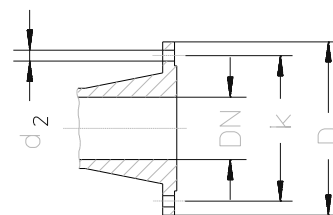

Arrangement drawing LEH 1200, LEH 1500, LEH 1800 with overhead liquid separator

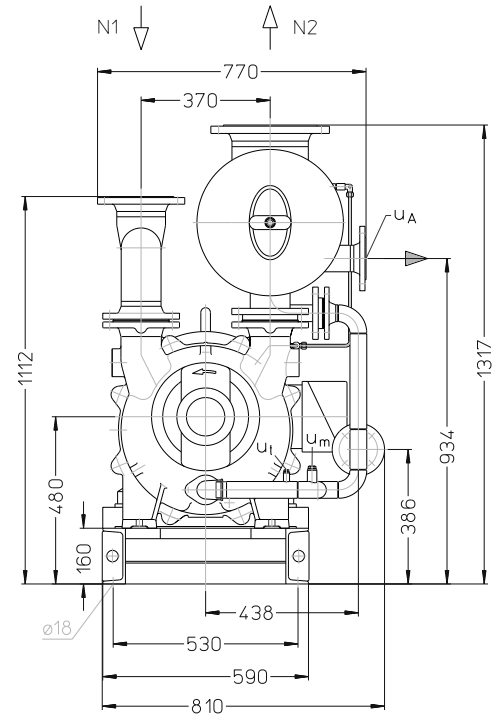
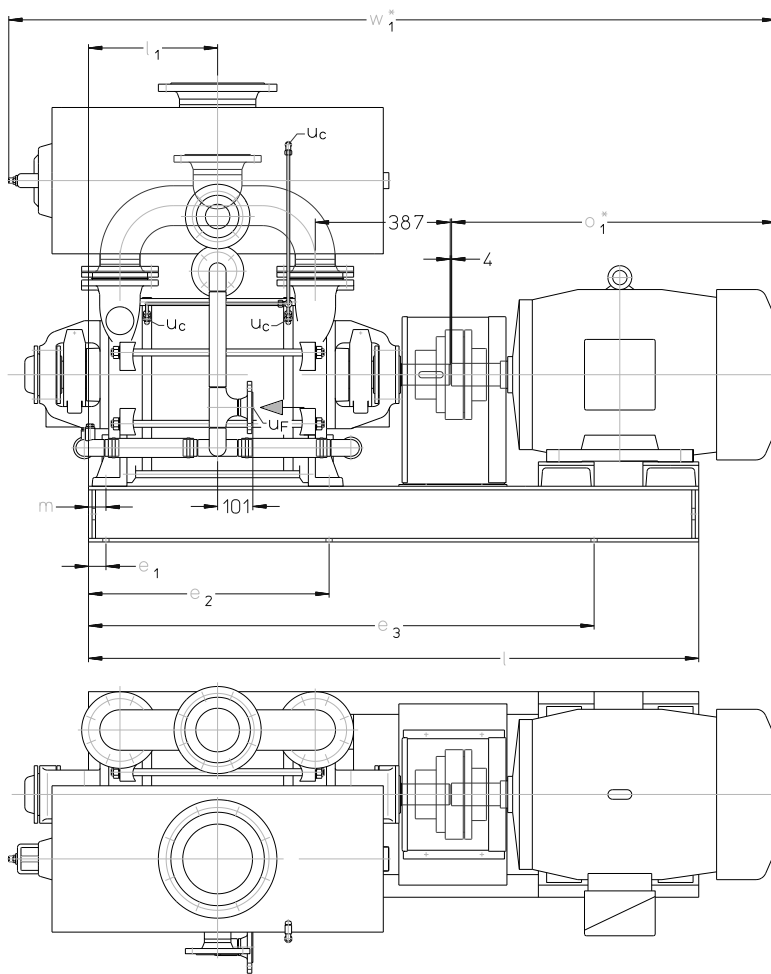

N 1 = gas inlet DN 125

N 2 = gas outlet DN 200

u_A = connection for liquid drain DN 65

u_F = connection for fresh liquid DN 40

u_c = connection for protection against cavitation G ¼

u_m = connection for pressure gauge G ½

u_t = connection for thermometer G ¼

	electric motor 50 Hz			e ₁	e ₂	e ₃	l	l ₁	m	o ₁ *	w ₁ *	weight app. kg
	size	IP 55	kW EEx e II T3									
LEH 1200	225 M	30	-	70	640	1370	1650	355	70	843	2043	1100
	250 M	-	33								930	1225
LEH 1500	250 M	37	-	50	690	1450	1750	370	50	1004	2200	1260
	280 S	-	40								2274	1455
LEH 1800	280 S	45	-	735	1530	1530	1900	388	40	1055	2329	1500
	280 M	-	46								2380	1570

flange connections to DIN 2501 PN 10				
DN	40	65	125	200
k	110	145	210	295
D	150	185	250	340
number x d ₂	4 x 18	4 x 18	8 x 18	8 x 22

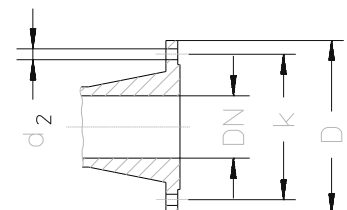

* dimensions dependent on the motor make

Arrangement drawing LEH 1200, LEH 1500, LEH 1800 with upright liquid separator

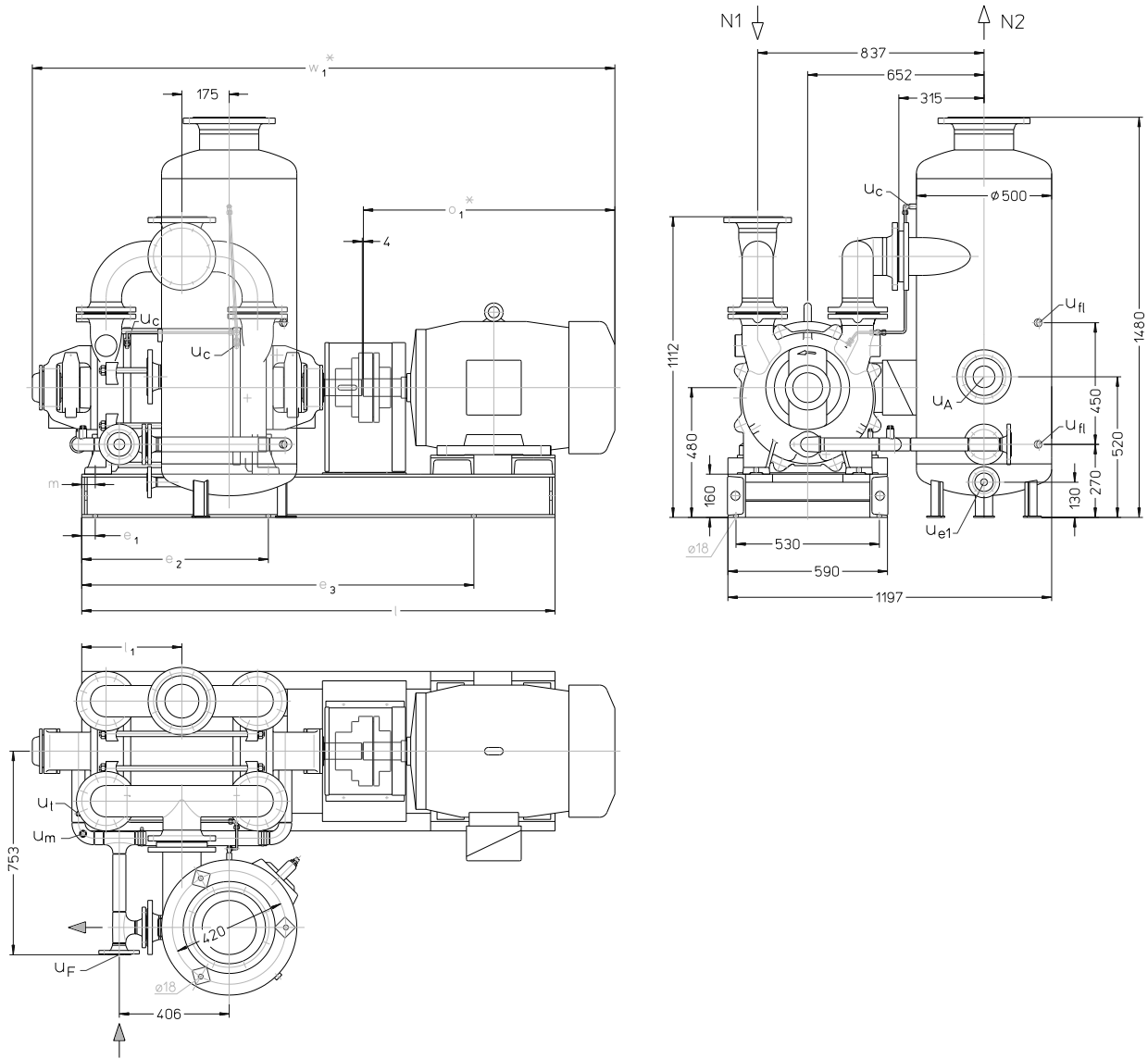

- N 1 = gas inlet DN 125
- N 2 = gas outlet DN 200
- u_A = connection for liquid drain DN 80
- u_F = connection for fresh liquid DN 40
- u_C = connection for protection against cavitation G ¼
- u_{e1} = drain connection DN 25
- u_{fi} = connection for liquid level indicator G ½
- u_m = connection for pressure gauge G ½
- u_t = connection for thermometer G ¼

	electric motor 50 Hz			e ₁	e ₂	e ₃	l	l ₁	m	o ₁ *	w ₁ *	weight app. kg
	size-	IP 55	kW EEx e II T3									
LEH 1200	225 M	30	-	50	640	1370	1650	355	70	843	1997	1100
	250 M	-	33		690	1450	1750			930	2084	1225
LEH 1500	250 M	37	-		735	1530	1900	388	40	1004	2228	1455
	280 S	-	40		735	1530	1900			1055	2334	1565

flange connections to DIN 2501 PN 10					
DN	25	40	80	125	200
k	85	110	160	210	295
D	115	150	200	250	340
number x d ₂	4 x 14	4 x 18	8 x 18	8 x 18	8 x 22

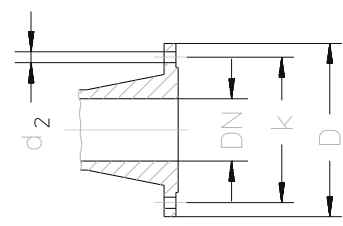

*dimensions dependent on the motor make

Fresh water requirements in [m³/h] dependent on suction pressure, speed, mode of operation and difference in temperature

suction pressure in [mbar]		33			120			200			400						
pump	speed [rpm]	KB			FB	KB			FB	KB			FB				
		difference in temperature [°C]				difference in temperature [°C]				difference in temperature [°C]							
		10	5	2		10	5	2		10	5	2					
LEH 1200	975	1,3	2,3	4,3	10	1,7	2,7	4,3	7,2	1,7	2,7	4,2	6,4	1,7	2,5	3,6	5,0
	1175	1,9	3,2	5,4		2,1	3,3	4,9		2,2	3,2	4,6		2,1	2,9	3,9	
LEH 1500	975	1,5	2,7	4,8		2,0	3,1	4,7		2,0	3,1	4,5		1,9	2,8	3,8	
	1175	2,2	3,7	5,9		2,5	3,7	5,2		2,5	3,6	4,9		2,3	3,2	4,1	
LEH 1800	975	1,8	3,0	5,2		2,2	3,3	4,9		2,2	3,3	4,7		2,1	3,0	3,9	
	1175	2,5	4,0	6,3		2,7	3,9	5,4		2,7	3,8	5,1		2,5	3,4	4,2	

FB = fresh liquid service

KB =combined liquid service with service water 10 °C, 5 °C, 2 °C warmer than the fresh water.

Data regarding the pump size - order notes

series + size	hydraulics + bearings	shaft sealing	material design	casing seal
	<ul style="list-style-type: none"> A• hydraulic A •B two grease lubricated antifriction bearings 	<ul style="list-style-type: none"> 041 double gland packing AAE mechanical seal O-rings Perbunan AA1 as AAE, but O-rings Viton 	<ul style="list-style-type: none"> 0B main parts of GG without non-ferrous metal 4B main parts of Cr Ni Mo-cast steel 	<ul style="list-style-type: none"> 0 liquid seal
LEH 1200 1500 1800	AB	041, AAE, AA1	0B, 4B	0

Design - Motor selection table

	designation	electric motor 50 Hz					
		motor enclosure IP 55			motor enclosure EEx e II T3		
		kW	size	designation	kW	size	designation
pump with free shaft end	01						
pump with coupling, pre-drilled at motor side	04						
as above, but with motor, for example 37 kW three-phase motor (50 Hz, 400 VΔ) at 975 rpm	e.g. BC	30	225 M	AC	33	250 M	BL
		37	250 M	BC	40	280 S	CL
		45	280 S	CC	46	280 M	DL

Example for ordering:

The construction size LEH 1500 AB AAE 0B 0 with 37 kW three-phase ac motor (50 Hz, 400 VΔ) 975 rpm has the complete order number:

LEH• 1500 AB AAE 0B 0

BC

If motors with other voltage or frequency are required a special information should be given.

On delivery the point (•) in the fourth place of the type code is replaced by a letter in the factory.

Accessories

Recommended accessories			LEH 1200	LEH 1500	LEH 1800
Overhead liquid separator		type	XBa 11540		
material design	130 / galvanized 172 / 1.4571	weight	96 kg	XBa 12540 100 kg	XBa 13240 104 kg
service liquid line		SIHI part No.	35 008 563	35 009 504	35 009 509
material design	072 / St 37-0 172 / 1.4571	SIHI part No.	35 008 564	35 009 506	35 009 510
cavitation protection line		SIHI part No.	35 005 440	35 005 442	35 005 444
material design	072 / St 37-0 172 / 1.4571	SIHI part No.	35 005 441	35 005 443	35 005 445
Upright liquid separator		type	XBp 2315		
material design	130 / galvanized 172 / 1.4571	weight	98 kg		
service liquid line		SIHI part No.	35 005 449		
material design	072 / St 37-0 172 / 1.4571	SIHI part No.	35 005 447		
cavitation protection line		SIHI part No.	35 005 434	35 005 436	35 005 438
material design	072 / St 37-0 172 / 1.4571	SIHI part No.	35 005 435	35 005 437	35 005 439
SIHI-gas ejector					
at service liquid temperature		15 °C	GEV 1200 A	GEV 1500 A	GEV 1800 A
at service liquid temperature		30 °C	GEV 1200 B	GEV 1500 B	GEV 1800 B
SIHI-ball type non-return valve		type / weight	XCk 150 / 35,8 kg resp. 43 kg		
material design	767 / GG-25 784 / 1.4408	SIHI part No.	20 072 800		
Reduction		weight	16,5 kg		
material design	072 / St 37-0 172 / 1.4571	SIHI part No.	35 002 762		
Motor in case of standard design					
IP 55		size	225 M	250 M	280 S
		power	30 kW	37 kW	45 kW
		weight	315 kg	420 kg	605 kg
EEx e II T3		size	250 M	280 S	280 M
		power	33 kW	40 kW	46 kW
		weight	420 kg	605 kg	670 kg
Coupling					
for motor IP 55		type / weight	A 180 / 14 kg	A 180 / 14 kg	A 180 / 14 kg
pump side		SIHI part No	43 035 527	43 035 527	43 035 527
motor side			43 021 496	43 034 392	43 021 495
for motor EEx e II T3		type / weight	ADS 194 / 17,5 kg	ADS 194 / 17,5 kg	ADS 218 / 24 kg
pump side		SIHI part No	43 040 600	43 040 600	43 040 602
motor side			43 035 601	43 038 678	43 038 708
contact safety device					
material design	076 / steel 345 / 2.0321	SIHI part No.	35 004 798		
base frame					
for motor IP 55	081 / USt 37-1	SIHI part No.	35 005 431	35 005 432	35 005 433
		weight	150 kg	155 kg	166 kg
for motor EEx e II T3	081 / USt 37-1	SIHI part No.	35 005 432	35 005 433	
		weight	155 kg	166 kg	

Any changes in the interest of the technical development are reserved.

Sterling SIHI GmbH

Lindenstraße 170, D-25524 Itzehoe, Germany
Telephone +49 (0) 48 21 / 7 71-01, Fax +49 (0) 48 21 / 7 71-274
www.sihi.com