

Liquid ring vacuum pumps

single-stage

LOH 20103, LOH 20107

Pressure range: 150 to 1013 mbar
Suction volume flow: 7 to 58 m³/h

CONSTRUCTION TYPE

Sterling SIHI liquid ring vacuum pumps are displacement pumps of uncomplicated and robust construction with the following particular features:

- handling of nearly all gases and vapours
- non-polluting due to nearly isothermal compression
- oil-free, as no lubrication in the working chamber
- small quantities of entrained liquid can be handled
- easy maintenance and reliable
- Low noise and nearly free from vibration
- wide choice of material, therefore applicable nearly everywhere
- incorporated central drain
- no metallic contact of the rotating parts

The Sterling SIHI liquid ring vacuum pumps LOH 20103 and LOH 20107 are single-stage ones. They can be applied without modification as compressors up to a compression pressure of 1 bar (see catalogue part K).

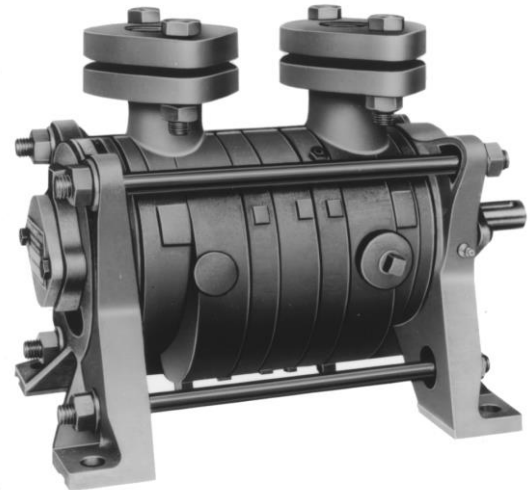

APPLICATION

Handling and exhausting of dry and humid gases; entrained liquid can be handled during normal duty. The pumps are applied in all fields where a pressure of 150 to 900 mbar must be created by robust vacuum pumps.

- Fields of application are for example:
- chemistry and pharmacy for distilling and degassing,
 - electric industry for impregnation and drying
 - plastics industry for degassing etc.

NOTE

During operation the pump must be continuously supplied with service liquid, normally water, in order to eliminate the heat resulting from gas compression and in order to replenish the liquid ring, because part of the liquid is leaving the pump together with the gas. This liquid can be separated from the gas in a liquid separator (see catalogue part accessories).

Reuse of the service liquid is possible.
 The direction of rotation of the pump is clockwise when looking from the drive on the pump.

GENERAL TECHNICAL DATA

Pump Type	units	LOH 20103	LOH 20107
Speed	50 Hz 60 Hz	2800 3400	2800 3400
Maximum overpressure on compression	bar		
Permissible pressure difference between suction and discharge side	bar		2.0 0.2
Hydraulic test pressure (Overpressure)	bar		3
Moment of inertia of rotating parts of pump and water content	kg · m²	0.0033	0.005
Noise level at 80 mbar suction pressure	dB (A)		66 67
Minimum permissible pulley diameter for V belt drive	mm		80
Maximum gas temperature	dry saturated		200 100
Service liquid:			
Maximum permissible temperature	°C		80
Minimum permissible temperature	°C		10
Maximum viscosity	mm²/s		90
Maximum density	kg/m³		1200
Liquid capacity up to middle of shaft	litre	0.9	1.0
Maximum flow resistance of the heat exchanger	bar		0.2

In selecting a pump, avoid choosing one which is likely to be operating at a combination of its maximum permissible limits e.g. maximum viscosity and maximum permissible pressure difference.

Materials

POSITION NUMBER	COMPONENTS	MATERIALS	
		0K	42
0001, 0002	casing	0.6025	1.4408
0010, 0011	intermediate piece		
0030	vane wheel impeller	1.4308	1.4517
0035	central body	1.0553	1.4571
0200	shaft	1.4021	1.4401
0500, 0600	mechanical seal	Cr-steel / carbon / butadiene rubber	Cr Ni Mo-steel / carbon / Viton

Cut-away diagram LOH 20103, LOH 20107

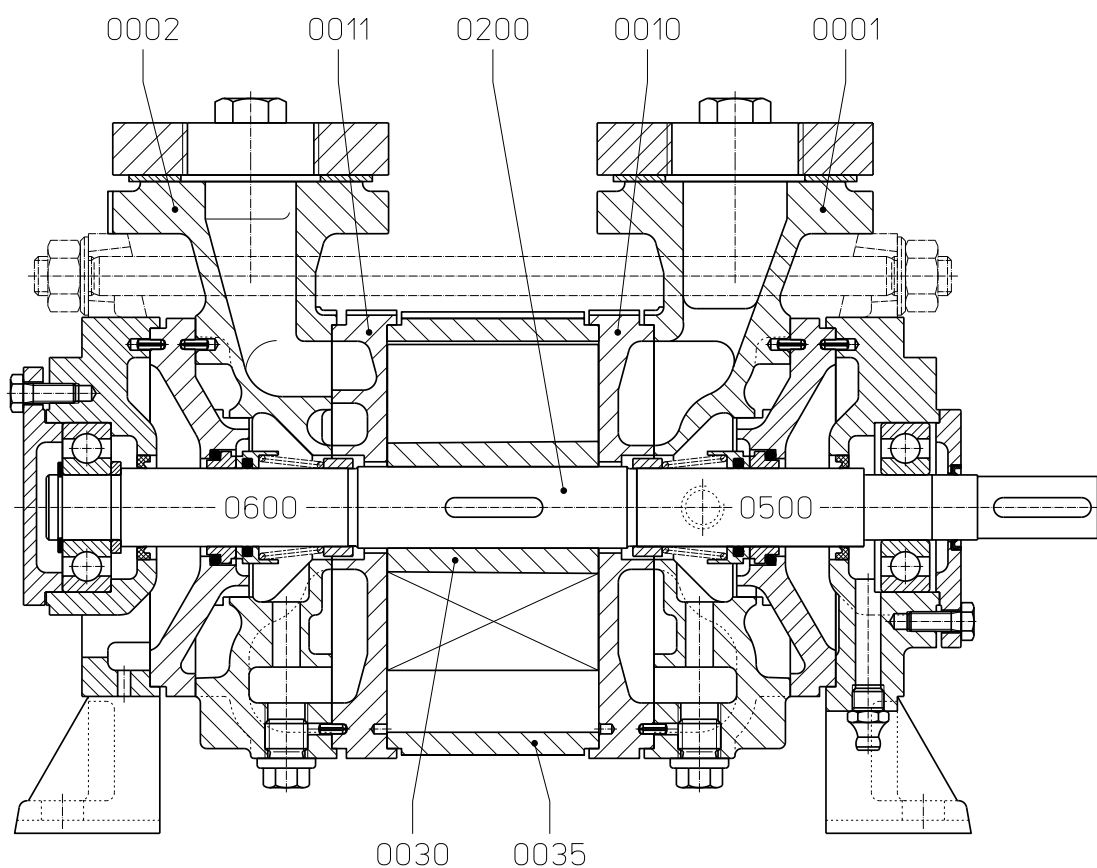

Performance Characteristics LOH 20103

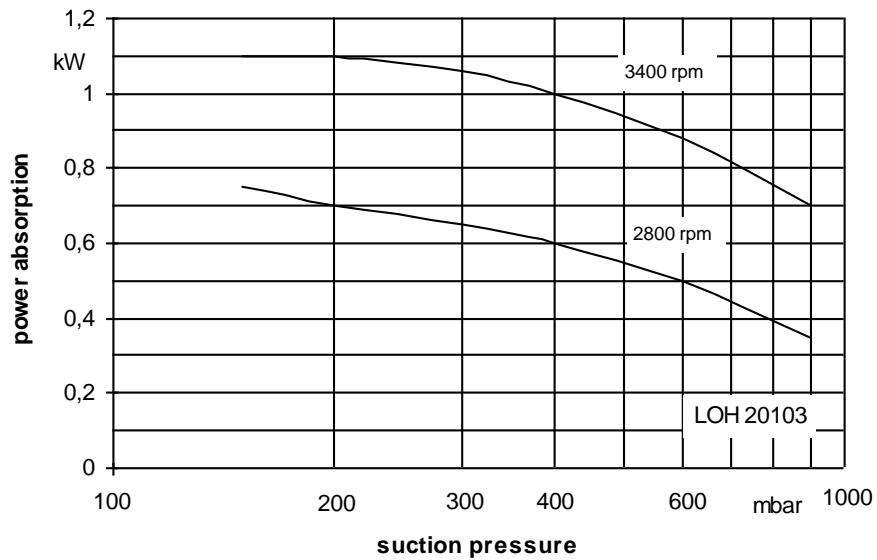
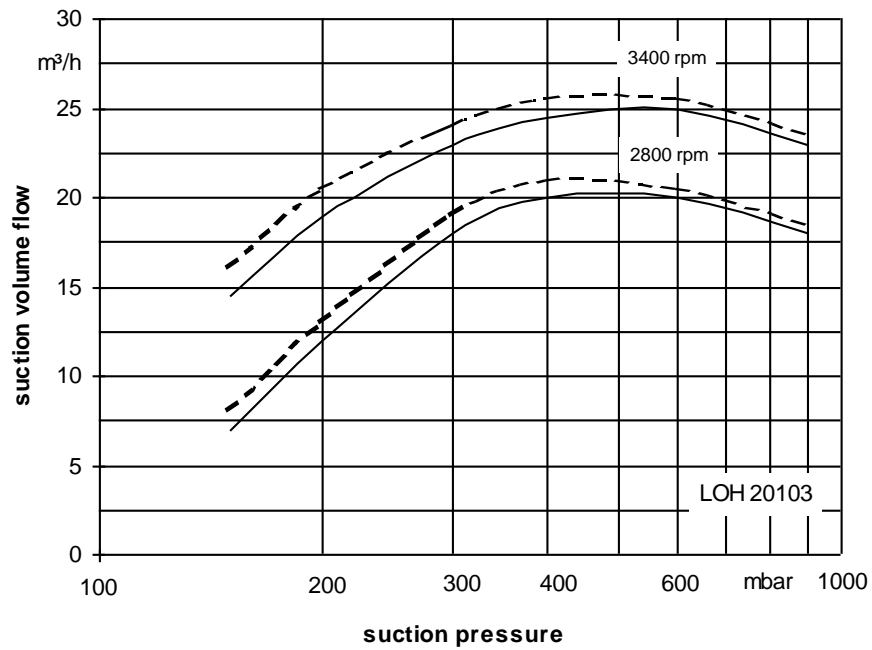

The operating data is valid under the following conditions:

- Process media:
 - dry air: 20°C —————
 - steam saturated air: 20°C - - - - -
- Service liquid:
 - water: 15°C

Pressure of gas to be evacuated: 1013 mbar (Atmospheric pressure)

The suction volume is related to the suction pressure.

Tolerance on operating data is 10% and on power absorption is 5%.

The maximum consumption of make-up water occurs at the lowest suction pressure.

Performance Characteristics LOH 20107

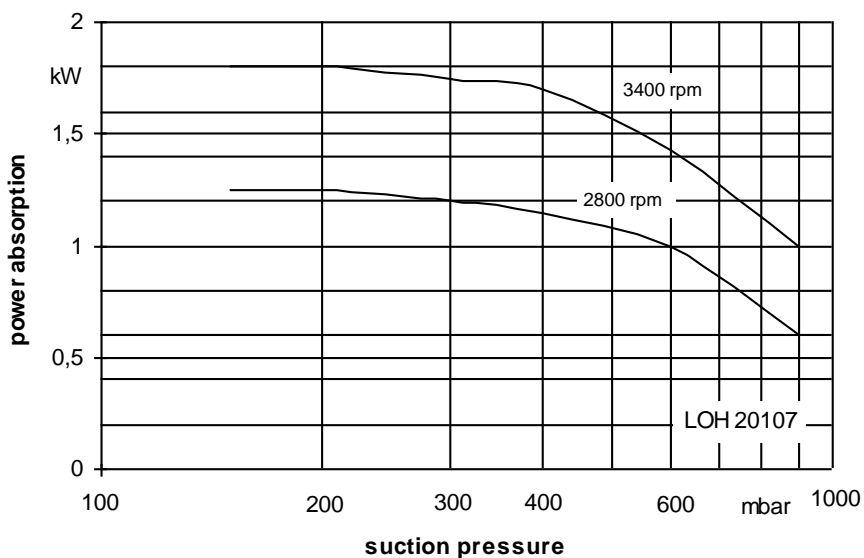
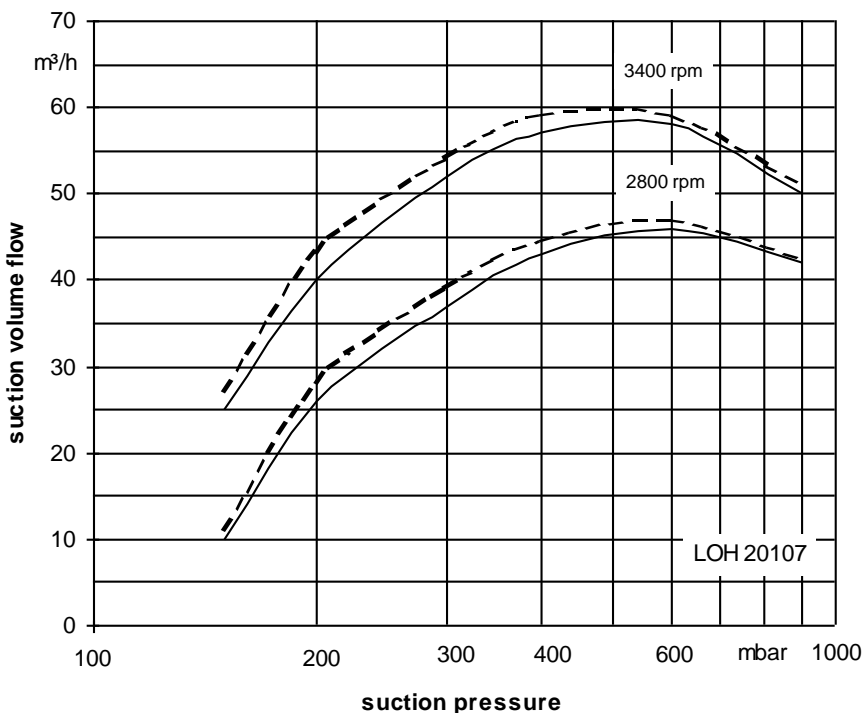

The operating data is valid under the following conditions:

- Process media:
 - dry air: 20°C
 - steam saturated air: 20°C
- Service liquid:
 - water: 15°C

Pressure of gas to be evacuated: 1013 mbar (Atmospheric pressure)

The suction volume is related to the suction pressure.

Tolerance on operating data is 10% and on power absorption is 5%.

The maximum consumption of make-up water occurs at the lowest suction pressure.

Dimensions LOH 20103, LOH 20107

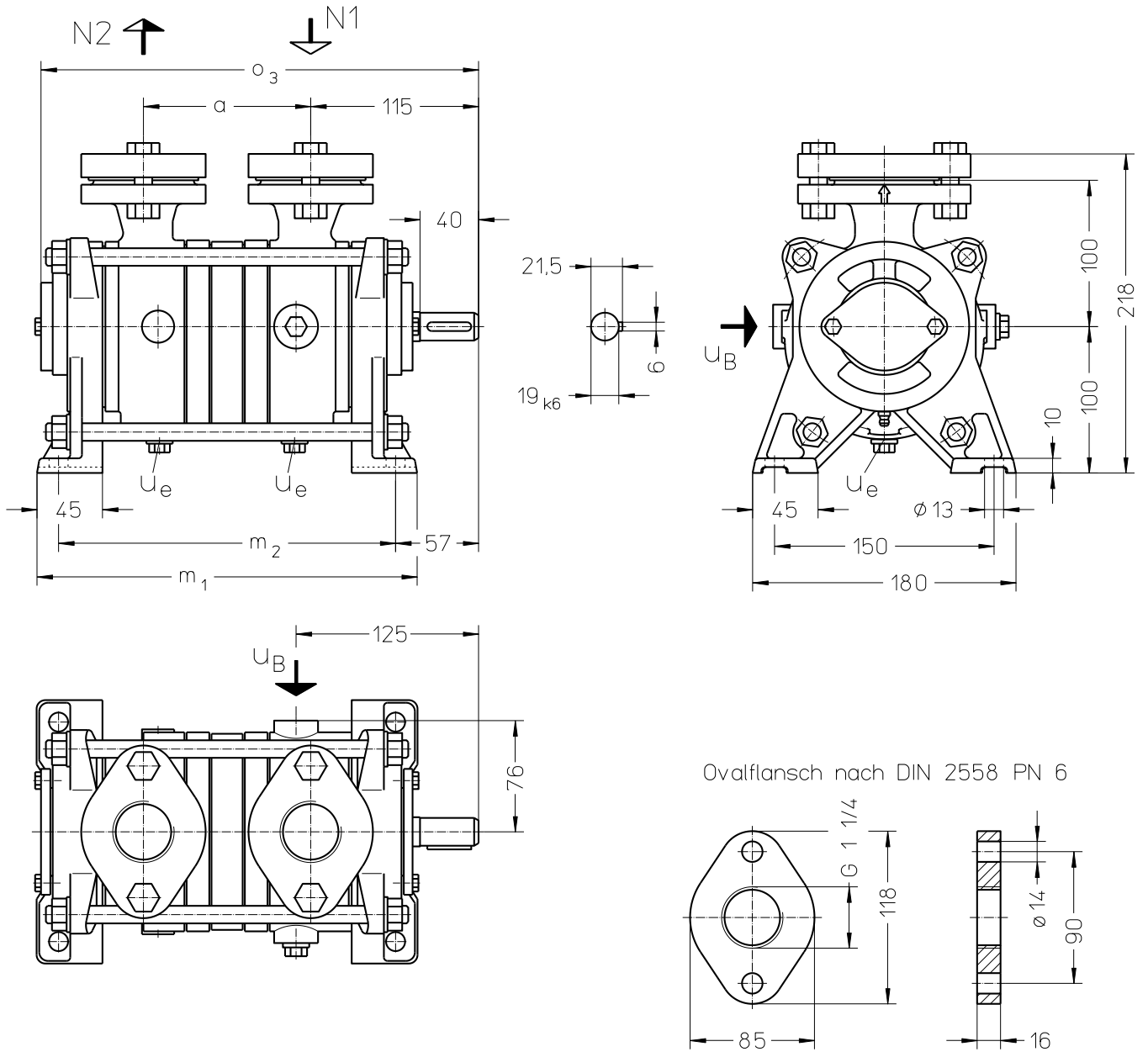

- N 1 = gas inlet G 1 1/4
- N 2 = gas outlet G 1 1/4
- u_B = connection for service liquid G 3/8
- u_e = drain connection G 1/4

	a [mm]	m ₁ [mm]	m ₂ [mm]	o ₃ [mm]	approx. weight [kg]
LOH 20103	114	260	230	299	20
LOH 20107	149	295	265	334	21

Arrangement drawing LOH 20103, LOH 20107 with overhead liquid separator

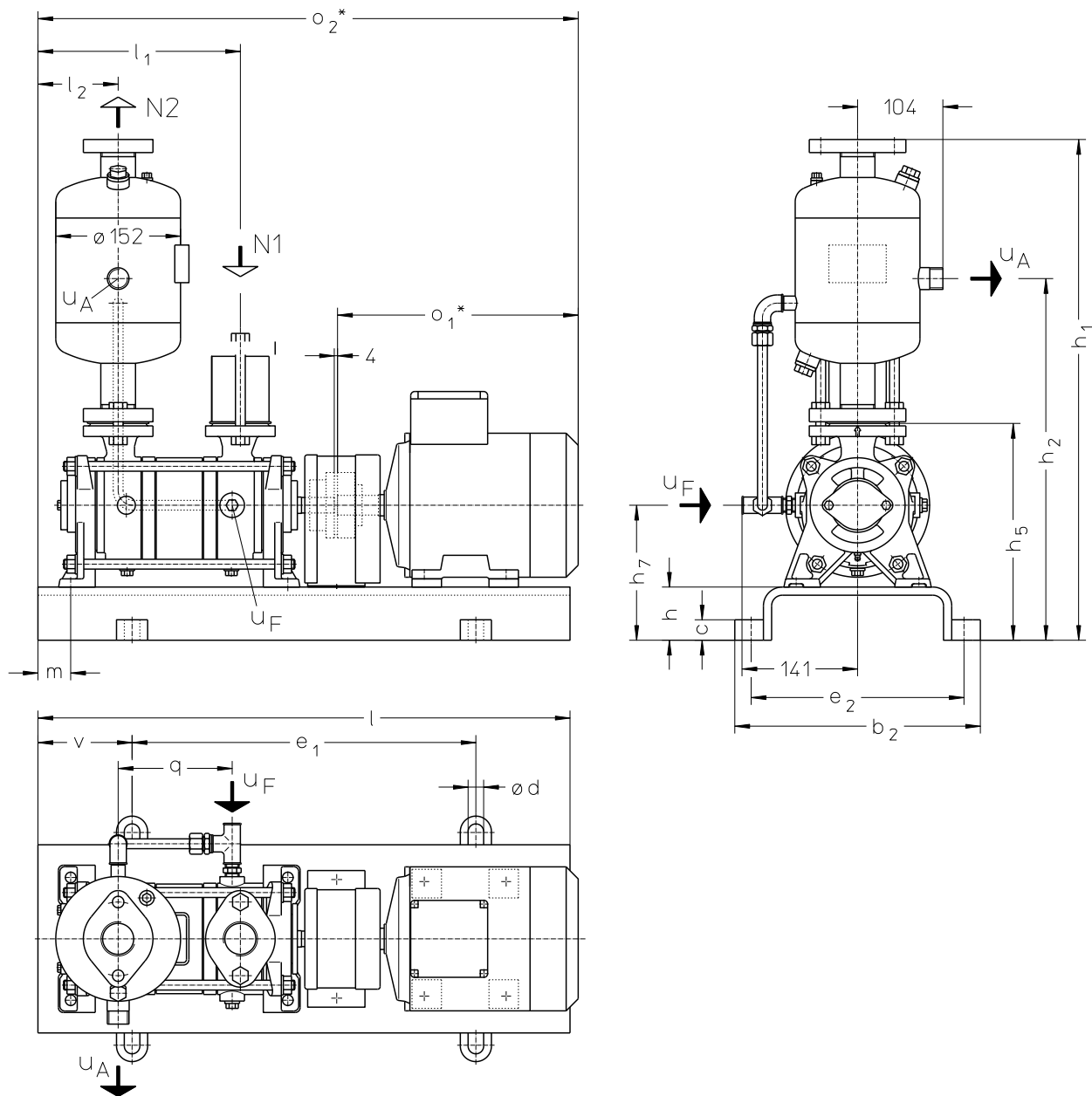

- N 1 = gas inlet G 1¼
- N 2 = gas outlet G 1¼
- u_A = connection for liquid drain G ¾
- u_F = connection for make-up liquid G ¾

	electric motor 50 Hz			b ₂	c	d	e ₁	e ₂	h	h ₁	h ₂	h ₅	h ₇	l	l ₁	l ₂	m	o ₁ *	o ₂ *	q	v	approx. weight [kg]
	size	IP 55	kW EExe II T3																			
LOH 20103	80a	0.75	-	317	20	15	350	285	35	612	412	235	135	570	212	98	40	274	605	104	110	45
	80b	1.1	-																			
	80a	-	0.75																			
	80b	-	1.1																			
LOH 20107	80b	1.1	-	300	25	19	420	260	65	582	442	265	165	650	267	118	60	274	660	139	115	58
	80b	-	1.1																			
	90S	1.5	-																			
	90S	-	1.5																			
	90L	-	2.0																			

* dimensions dependent upon the motor supplier

Make-up Liquid Consumption in [m³/h] dependent upon suction pressure, speed, drive type and temperature difference.

Suction pressure in [mbar]		150					400					600					900				
Pump Type	Speed [rpm]	KB				FB	KB				FB	KB				FB	KB				FB
		Temperature Difference °C					Temperature Difference °C					Temperature Difference °C					Temperature Difference °C				
		20	10	5	2		20	10	5	2		20	10	5	2		20	10	5	2	
LOH 20103	2800	0.03	0.05	0.09	0.16	0.3	0.02	0.04	0.07	0.13	0.27	0.02	0.04	0.06	0.11	0.21	0.01	0.02	0.04	0.06	0.1
	3400	0.04	0.07	0.12	0.18		0.04	0.07	0.11	0.17		0.03	0.06	0.09	0.14		0.02	0.04	0.05	0.08	
LOH 20107	2800	0.05	0.08	0.13	0.21	0.35	0.04	0.07	0.11	0.17	0.27	0.04	0.06	0.09	0.14	0.21	0.02	0.03	0.05	0.07	0.1
	3400	0.06	0.11	0.16	0.24		0.06	0.09	0.14	0.20		0.05	0.08	0.11	0.16		0.03	0.05	0.06	0.08	

FB = Total service liquid flow rate on once-through system

KB = combined liquid service with service water 20 °C, 10°C, 5°C or 2°C warmer than the fresh water

Product Code - order details

Range + Size	Hydraulic + Bearings	Shaft Seal	Materials	Casing sealing
	<ul style="list-style-type: none"> • B 2 antifriction bearings • N 1 shaft end, clockwise 	131 X0A mechanical seal	0K main parts out of cast iron, impeller 42 Main parts of stainless steel	0 liquid seal
LOH <u>20103</u> 20107	BN	131, X0A	0K, 42	0

Motor Selection

For our products we offer a lot of different motor types.

To identify the right motor please specify frequency, voltage and protection class.

Example of an Order:

LOHE 20103 BN 131 0K 0 with 1.1 kW AC motor, 50 Hz, 230V Δ, IP55

Accessories

Recommended accessories		Material execution		LOH 20103	LOH 20107
Top mounted liquid separator		Type / Weight	XBa 342 / 6 kg		
Top mounted separator	1.4571	SIHI-Part No.	43 132 176		
Service liquid pipework	Steel, galvanised 1.4571	SIHI-Part No.	20 054 559 20 054 560		
Sterling SIHI – Non return ball valve					
Intermediate flange execution XCK 32	0.6025 + Butadiene rubber 0.6025 + Teflon 1.4408 + Teflon	SIHI-Part No. Weight	20 072 744 / 1.2 kg 20 072 769 / 1.3 kg 20 085 240 / 3.3 kg		
Flange execution with glass cylinder XCK 324	0.6025 + Butadiene rubber 0.6025 + Teflon	SIHI-Part No. Weight	20 072 832 / 7.0 kg 20 072 833 / 7.0 kg		
Motor					
Motor standard execution IP 55		Size Power Weight	80 A 0.75 kW 8 kg	80 B 1.1 kW 10 kg	
		Size Power Weight	80 B 1.1 kW 10 kg	90 S 1.5 kW 13 kg	
Coupling for motor IP 55		Type / Weight	B 80 / 1.5 kg		
Pump side		SIHI-Part No.	43 021 409		
Motor side (for motor 80 A and 80 B)		SIHI-Part No.	43 021 420		
Motor side (for motor 90 S)		SIHI-Part No.	43 039 231		
Coupling guard	Steel	SIHI-Part No.	43 042 201		
Motor					
Motor in EEx e II T3 execution		Size Power Weight	80 A 0.75 kW 11 kg	80 B 1.1 kW 12 kg	
		Size Power Weight	80 B 1.1 kW 12 kg	90 S 1.5 kW 14 kg	
		Size Power Weight		90 L 2 kW 16 kg	
Coupling for motor EEx e II T3		Type / Weight	BDS 88 / 2 kg		
Pump side		SIHI-Part No.	43 111 026		
Motor side (for motor 80 A and 80 B)		SIHI-Part No.	43 111 034		
Motor side (for motor 90 S and 90 L)		SIHI-Part No.	43 111 055		
Coupling guard	Brass	SIHI-Teil Nr.	43 042 202		
Baseplate	Steel	Type / Weight SIHI-Part No.	S 007 / 8 kg 43 040 647	S 210 / 19.3 kg 43 040 630	

Any changes in the interest of the technical development are reserved.

Sterling SIHI GmbH

Lindenstraße 170, 25524 Itzehoe, Germany, Telephone +49 (0) 48 21 / 7 71 - 01, Fax +49 (0) 48 21 / 7 71-274