

# Air separator

Air separator

AT 8072B

Art. No	R S K	Application	Performance	Body material	Sealing material	D N	P N	Temperature (°C)	Connection
		F	F	F,R		R	R	R	F,R
8072B020		Venting water	Automatic venting	Brass		20	10	0-110	Internal/external thread
8072B225		Venting water	Automatic venting	Brass		25	10	0-110	Internal/external thread
8072B322		Venting water	Automatic venting	Brass		32	10	0-110	Internal/external thread
8072B400		Venting water	Automatic venting	Brass		40	10	0-110	Internal/external thread
8072B500		Venting water	Automatic venting	Brass		50	10	0-110	Internal/external thread

<b>Dimension range</b> G 3/4 - G 2	<b>PN</b> 10	<b>Temperature range</b> 0 °C to 110 °C	<b>Material</b> Brass
---------------------------------------	-----------------	--	--------------------------

# Air separator

Air separator

AT 8072B

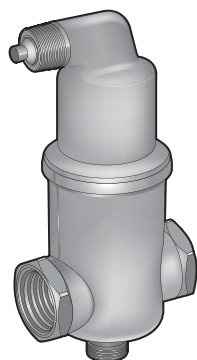

AT 8072B

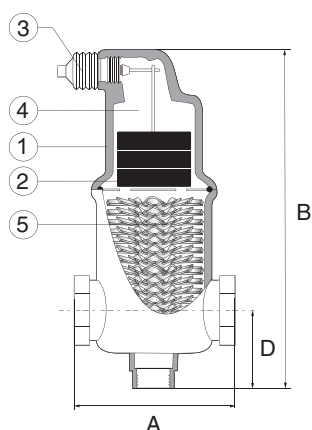

## Range of application

For automatic air separation of heating and cooling systems where the fluid is water or glycol. Can be mounted in systems with a mix of water/glycol and water/ethanol, if control and oversight is increased. The valve should not be used in systems with a mix of water/salts. Separates effective microbubbles.

## PSF.141 Air separator

Automatic air-/particle separator AT8072B... of brass, PN10, gas separator, large air chamber with dirt protection.

Fulfills AFS 1999:4, 8§ standards and shall not be CE-marked.  
All separators are functional- and density tested.

## Details

- |   |  |
|---|--|
| 1 | Body and top of brass  |
| 2 | Float of polypropylen, suspended in a bar  |
| 3 | Unique valve mechanism in leak proof performance   |
| 4 | Air chamber with large volume for max. operation safety  |
| 5 | Gasseparator helistill optimally separates the free gas bubbles, including microbubbles from the fluid |

## Dimensions and weight

Connection	G 3/4	G 1	G 1 1/4	G 1 1/2	G 2
A	85	88	88	88	132
B	153	180	200	234	275
D	20	35	40	42	58
Weight	1,0	1,3	1,4	1,6	3,9

Dimensions in mm. Weight in kg.

## Function and design

The velocity decreases as the fluid flows into the separation body and the gas-free bubbles are being optimally separated when they pass through the separator. The separated bubbles flows up into the the float body. The liquid level goes down and the float sinks.

The float, that is connected with the separation mechanism by a chain, has reached a certain low level, the mechanism is affected and air can flow into the free. When the float rises again, the mechanism closes. The large volume of the air chamber and special design makes the liquid level never reach the drainage mechanism, even if the air in the chamber is compressed to 10 bar.

## Technical information

Connection	20	25	32	40	50
Max flow l/sec	0,35	0,55	1,0	1,4	2,1
Max flow m <sup>3</sup> /h	1,3	2,0	3,6	5,0	7,5
Pressure drop bar	0,017	0,013	0,014	0,014	0,02

Values above apply at max. speed 1 meter/second.

Rätten till ändringar utan föregående meddelande förbehålls.  
Armatec ansvarar inte för eventuella tryckfel eller misstänksfel.  
Dokumentet får kopieras endast i sin helhet.

# Air separator

Air separator

AT 8072B

## Installing

Since the micro bubbles are released at the hottest point in the plant, the component should be placed on the hottest spoint in the system. In a heating system is the warmest point usually on the supply line, as close to the heater as possible. In order to maintain a good absorption effect, the static pressure at the site of installation should not exceed 15-20mvc.

In a cooling system is the warmest point often in the return line before the cooler. To enable the float to move and blow out the air the pressure needs to ba around 0,3-0,5 bar by the installation point.

## Maintenance and spare parts

The separator should be checked regularly and cleaned if necessary.

## Marking

Marked with dimension, max. operation pressure, max. operation pressure and the manufacturers name

## How to order

**Example: AT 8072B20**

Connection	AT-No.
G 3/4	8072B20
G 1	8072B25
G 1 1/4	8072B32
G 1 1/2	8072B40
G 2	8072B50