



armatec

## USER MANUAL

STOP VALVE

Type 3561

### CONTENTS

1. Product description
2. Requirement for maintenance staff
3. Transport and storage
4. Function
5. Application
6. Assembly
7. Maintenance
8. Service and repair
9. Reasons of operating disturbances and remedy
10. Valve service discontinuity
11. Warranty terms

### 1. PRODUCT DESCRIPTION

Stop valves are manufactured at different executions, they are used as stop valves, throttling valves, SDNR valves. Stop valves are designed only for shut off and open the flow, throttling valves are designed for flow control and SDNR valves are used as non return valves protecting the plant against back flow of medium and additionally they can shut off the flow. SDNR valves visually differ from stop valves having cylinder stem extension on the upper end of the stem.

SDNR valve (option)

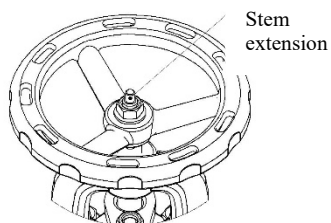

Stop valve

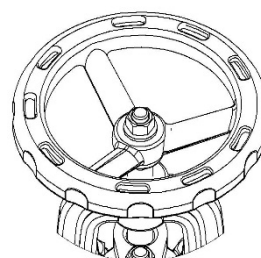

Type 3561 PN16 (A - 01)

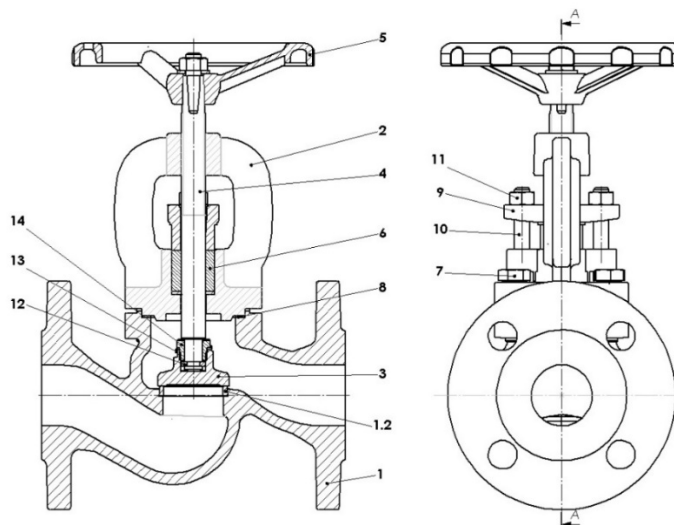



armatec

Angle PN16(option)

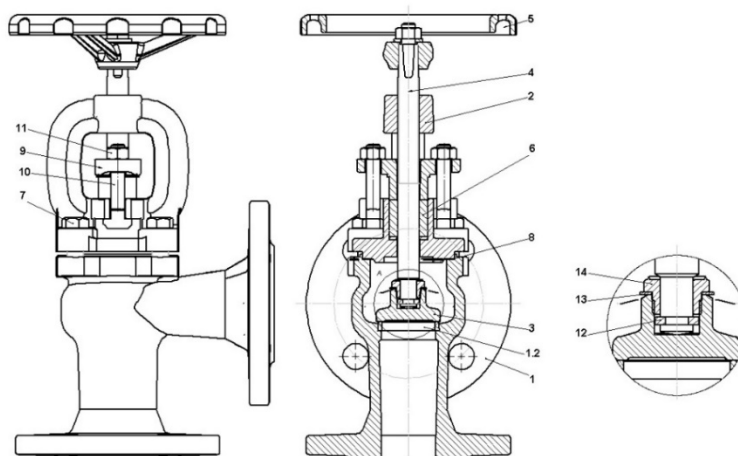

	Body material	A				C		
		Type	00	01;04;71;91	02;05;72;92	O3;13	01;04;71;91	02;05;72;92
1	Body	EN – GJL250 JL1040				EN – GJS400 – 18-LT JS1025		
1.2	Seat ring	X12Cr13 1.4006	CuSn10 – C CC480K		X12Cr13 1.4006	CuSn10 – C CC480K		
2	Bonnet	EN – GJL250 JL1040				EN – GJS400 – 18-LT JS1025		
3	Disc	X20Cr13 1.4021	CuSn10 – C CC480K		X20Cr13 1.4021	CuSn10 – C CC480K		
4	Stem	X20Cr13 1.4021	CuZn40Mn1,5	CuSn10 – C CC480K	X20Cr13 1.4021	CuZn40Mn1,5	CuSn10 – C CC480K	
5	Hand wheel	EN-GJS500-7 JS1050						
6	Glandpacking	Grafit						
7	Hexagonbolt	8.8			A2-70	8.8		
8	Gasket	Grafit + NiCr						
9	Gland	EN – GJL250 JL1040				EN – GJS400 – 18-LT JS1025		
10	T-bolt	5.8 + ocynk						
11	Nut	8 + ocynk						
12	Ring	----- -----	X20Cr13 1.4021	CuSn10 – C CC480K		X20Cr13 1.4021	CuSn10 – C CC480K	
13	Lock washer	----- -----	X6CrNiTi18- 10 1.4541	CuSn6		X6CrNiTi18- 10 1.4541	CuSn6	
14	Screw	----- -----	X20Cr13 1.4021	CuSn10 – C CC480K		X20Cr13 1.4021	CuSn10 – C CC480K	
Max. temperature		300°C	300°C	225°C	225°C	350°C	225°C	225°C



armatec

Type 3561 PN40 (F - 01)

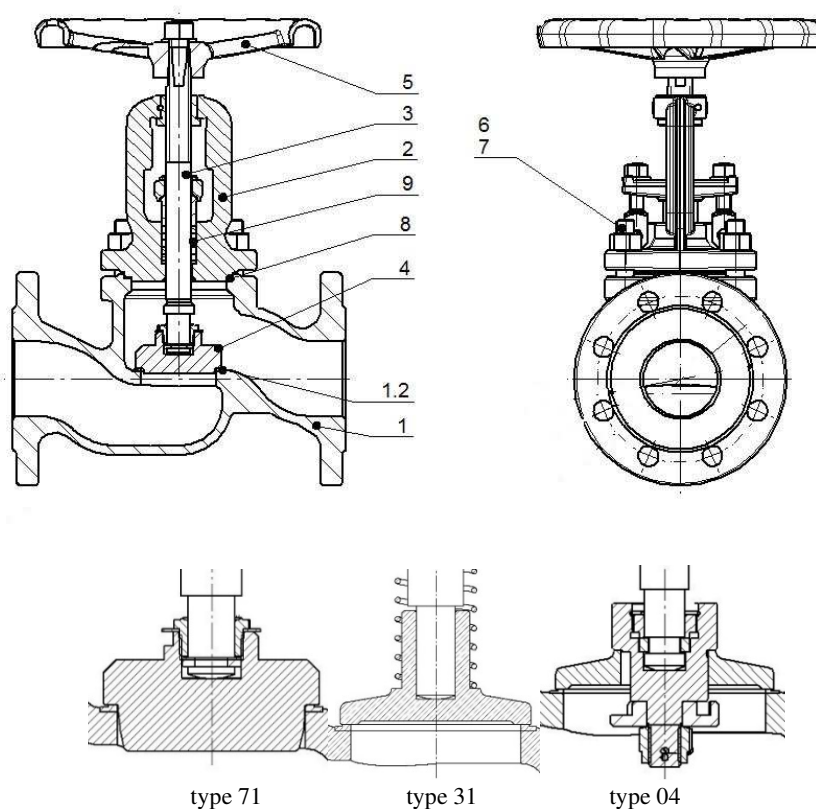

	Body material	F		I	
		01 04 71	31	01 0471	31
1	Body	GP240GH 1.0619		GX5CrNiMO19-11-2 1.4408	
1.2	Paddingweld	Drut G 19 9 LSi / Stellit 21		Drut G 19 9 LSi / Stellit 21	
2	Bonnet	GP240GH 1.0619		GX5CrNiMO19-11-2 1.4408	
3	Stem	X20Cr13 1.4021		X6CrNiMoTi17-12-2 1.4571	
4	Disc	X20Cr13+QT 1.4021		X6CrNiMoTi17-12-2 1.4571	
5	Hand wheel	KOZ-120 PN-M-74203			
6	Studbolt	24CrMo4		A4-70	
7	Nut	24CrMo4		A4	
8	Bonnetgasket	Graphite + NiCr			
9	Glandpacking	Graphite			
10	Spring	-----	X17CrNi16-2	-----	X17CrNi16-2
<b>Max. temperature</b>		<b>450°C</b>		<b>400°C</b>	

Stop valves are provided with casted marking according to requirements of PN-EN19 standard. The marking facilitates technical identification and contains:

- nominal diameter DN (mm),
- nominal pressure PN (bar),
- body and bonnet material marking,
- arrow indicating medium flow direction,
- manufacturer marking,
- heat number,
- CE marking, for valves subjected 2014/68/UE directive. CE marking starts from DN32
- UKCA mark for valves subject to Regulation 2016 UK Nr. 1105. UKCA symbol with unit number from DN 32

## **2. REQUIREMENTS FOR MAINTENANCE STAFF**

The staff assigned to assembly, operating and maintenance tasks should be qualified to carry out such jobs. If the valve is provided with mechanical actuators, operating manual of actuator should be obeyed. If during valve operation heat parts of the valve, for example handwheel, body or bonnet parts could cause burn, user is obliged to protect them against touch.

## **3. TRANSPORT AND STORAGE**

Transport and storage should be carried out at temperature from  $-20^{\circ}$  to  $65^{\circ}$ C, and valves should be protected against external forces influence and destruction of painting layer as well. The aim of painting layer is to protect the valves against rust during transport and storage. Valves should be kept at unpolluted rooms and they should be also protected against influence of atmospheric conditions.



armatec

There should be applied drying agent or heating at damp rooms in order to prevent condensate formation. The valves should be transported in such a way to avoid handwheel and valve stem damage.



It is not allowed to fit lifting devices to connecting holes and handwheel.

4. FUNCTION

Valves with stop disc are designed for shut off medium flow, valves with throttling disc enable to control the flow and SDNR valves are designed to work as non return valves and enable to shut off the valve at any time as well.

Application range was mentioned at catalogue card. The kind of working medium makes some materials to be use or to be prohibited for use.

5.APPLICATION

- industry, shipbuildingindustry, chemicalindustry
- heating
- power engineering
- refrigeration, air conditioning
- industrial water
- steam
- compressedair
- diathermicoil,
- glycol
- neutralfluids

When selecting the valve for specific medium, "List of Chemical Resistance" can be helpful. It can be found at manufacturer website near catalogue cards.

Valves were designed for normal working conditions. In the case that working conditions exceed these requirements (for example for aggressive or abrasive medium) user should ask manufacturer before placing an order.

Working pressure should be adapted to maximum medium temperature according to the table as below.

Acc. EN 1092-2	PN		-60°C ÷ <-10°C		-10°C ÷ 120°C	150°C	200°C	250°C	300°C	350°C	400°C	450°C
EN-GJL250	6	bar	-----		6	5,4	4,8	4,2	3,6	---	---	---
	16		-----		16	14,4	12,8	11,2	9,6	---	---	---
EN-GJS400-18 LT	16		-----		16	15,5	14,7	13,9	12,8	11,2	---	---
	25		-----		25	24,3	23	21,8	20	17,5	---	---
Acc. EN 1092-1			-40°÷<-	-	50°C ÷ 100°C	150°C	200°C	250°C	300°C	350°C	400°C	450°C
GP240GH +N	40	bar	30	40	37,1	35,2	33,3	30,4	27,6	25,7	23,8	13,1
Acc. EN 1092-1			-60°÷<-10°C		-	150°C	200°C	250°C	300°C	350°C	400°C	450°C
G-X5CrNiMo19-11-2	40	bar	40		40	36,3	33,7	31,8	29,7	28,5	27,4	---



Acc. EN 1092-1		Temperature [° C]																		
Material	PN	-10 < do < 50	100	150	200	250	300	350	400	450	460	470	480	490	500	510	520	530	540	550
P245GH GP240 GH	63	63	58,5	55,5	52,5	48,0	43,5	40,5	37,5	20,7	-	-	-	-	-	-	-	-	-	-
	100	100	92,8	88,0	83,3	76,1	69,0	64,2	59,5	32,8	-	-	-	-	-	-	-	-	-	-
	160	160	137	130	124	113	103	97	91	47	-	-	-	-	-	-	-	-	-	-
13CrMo4-5	63	63	63	63	63	63	63	60,0	56,7	53,1	50,5	47,9	45,4	42,8	41,1	34,8	28,2	23,4	18,3	14,7
	100	100	100	100	100	100	100	95,2	90,0	84,2	80,2	76,1	72,0	68,0	65,2	55,2	44,7	37,1	29,0	23,3
	160	160	160	160	160	160	156	146	137	124	119	114	109	99	89	79	70	59	46	37

Table cells in gray relate to work in conditions of creep.

**!** Valves made of GP240GH cast steel and operating at temperatures above 400°C due to material creep, cannot operate under these conditions for more than 100,000 hours.

**!** Valves made of 13CrMo4-5 stainless steel and operating at temperatures above 490°C due to material creep, cannot operate under these conditions for more than 100,000 hours.

**!** The valve design withstands an unlimited number of fatigue cycles.

### 6. ASSEMBLY

During the assembly of stop valves following rules should be observed:

- to evaluate before an assembly if the valves were not damaged during the transport or storage,
- make sure that the valves used are appropriate for the operating parameters and media in a given installation,
- to take off dust caps if the valves are provided with them,
- during welding work, the valves should be protected against spatter,
- steam lines must be routed in such a way as to prevent the accumulation of water; to prevent water hammer a condensate separator should be used,



**!** The valves must not be installed as an end piece of the pipeline if the temperature is high valve will be less than minus 10°C.

**!** Pipeline where the valves are fitted should be conducted and assembled in such a way that the valve body is not subjected to bending moment and stretching forces.  
**!** Bolted joints on the pipeline must not cause additional stress resulted from excessive tightening, and fastener materials must comply with working conditions of the plant.

- during pipeline painting valve stem should be protected,
- stop valves can be assembled in any position, however it is recommended to install the valve with handwheel upwards,
- screw down and non-return valves (version with spring) can be assembled in any position, screw down and non-return valves (version without spring) should be assembled only on the horizontal pipelines with handwheel upwards

**!** It should be take note of medium flow direction, marked with an arrow on the body. Flow direction is established



**armatec**

according to the rules as below:

	Stop valve	SDNR and throttling disc valve	Stop valve	Stop valve	Stop valve
	PN6 – PN25	PN6 – PN40	PN40	PN 63-100	PN160
<b>Under the disc</b>	DN15 – DN150	DN15 – DN300	DN15 – DN125	DN15 – DN25	DN15 - DN50
<b>On the disc</b>	DN200 – DN300	-----	DN150 – DN200	-----	----

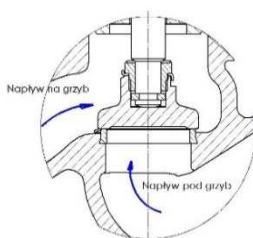

- during valve operation, hot valve parts, such as body or bonnet parts, may cause burns. If necessary, the user should put up insulating covers and warning plates,
- before starting the system, and in particular after repairs, flush the pipeline system with the valve fully open to remove solids or welding spatter harmful to the sealing surfaces,
- installing a strainer before the valve increases the certainty of its proper functioning.
- the valves have been designed for applications independent of external conditions.

If there is a risk of corrosion caused by external conditions (weather, aggressive vapours, gases, etc.), special anti-corrosion protection or special design of the valves is recommended.

**⚠ The designer of the installation, the contractor of construction works and the user are responsible for the correct selection of the valve to the conveyed medium and working conditions, as well as its arrangement and assembly.**

**⚠ Installations should be designed so as to prevent the negative effects of water hammer. This can be achieved by:**

- **reduction of the maximum pressure to the value permissible for the materials of the valves**
- **determination of the maximum pressure increase at the moment of water hammer and selection of appropriate DN diameter of the pipeline**
- **use of pumps with high inertia of rotors and regulation of pump revolutions**
- **use of overflow chambers and water-air tanks, airing valves or safety valves**
- **slow closing and opening of valves**

- before starting the system, and in particular after repairs, flush the pipeline system with the valve fully open to remove solids or welding spatter harmful to the sealing surfaces,
- installing a strainer before the valve increases the certainty of its proper functioning.

## 7. MAINTENANCE

During maintenance following rules should be observed:

- startup process – sudden changes of pressure and temperature should be avoided when starting the plant,



**armatec**

- valve is closed by turning the handwheel clockwise when looking from above the handwheel (according to arrow direction marked on the handwheel),

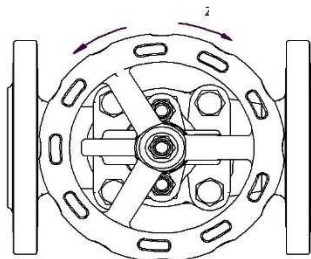

**It is prohibited to use additional lever when turning the handwheel**

- performance of fitted valves can be checked by multiple closing and opening. If leaks appear on the valve stem, tighten the valves with moderate force until the leakage stops, the two nuts on the bolts pressing the packing through the gland.
- in the case of necessity to replace packing rings, it should be done without overpressure inside the valve, when the valve is completely open. In this position inner space of the valve is entirely shut off : stop valves are provided with back seat on the upper part of disc which adheres to bonnet seat, SDNR valves are provided with flange on the stem which adheres to bonnet seat,
- in order to refill packing rings of valves 3561 (PN6 – PN25) unscrew the nuts on T-bolts, move the gland into handwheel direction, working under lifted gland refill cut - packing rings in the stuffing box, then press again these cut packing rings.

Fill the

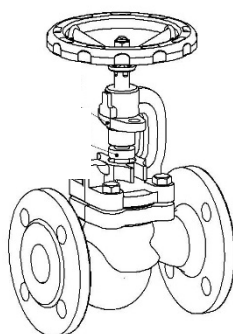

- valves in which there is an inflow over the disc are equipped with a balancing disc as shown below. Turning the handwheel to the left raises the balancing disc which results in equalization of upstream and downstream pressure. After pressure equalization the valve can be opened completely. The balancing disc operation is effective only in closed systems. In an open system where it is impossible to equalize pressure the balancing is ineffective. In this case, one should consider introduction of other structural solutions, e.g. a by-pass.

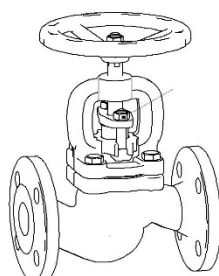



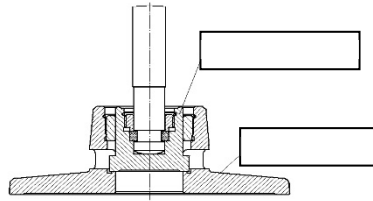

- The maximum differential pressure that can apply on both sides of the closing valve (the valve is closed) in valves where there is flow under the plug see in the table below.

differential pressure						



**In order to assure safety performance, each valve (especially rarely used) should be surveyed on regular basis. Inspection frequency should be laid down by user, but not less than one time per month.**

### 8. SERVICE AND REPAIR

All service and repair jobs should be carried out by authorized staff using suitable tools and original spare parts. Before disassembly of complete valve from the pipeline or before service, the pipeline should be out of operation. During service and repair jobs it is necessary to decrease pressure to 0 bars , valve temperature to ambient temperature and to use personal health protectives in pursuance of existing threat. After valve disassembly it is necessary to replace flange connection gaskets between valve and pipeline.



**Precautions should be taken when touching gasket between body and valve bonnet. The gasket contains stainless steel stripe that may cause injury,**

Gasket

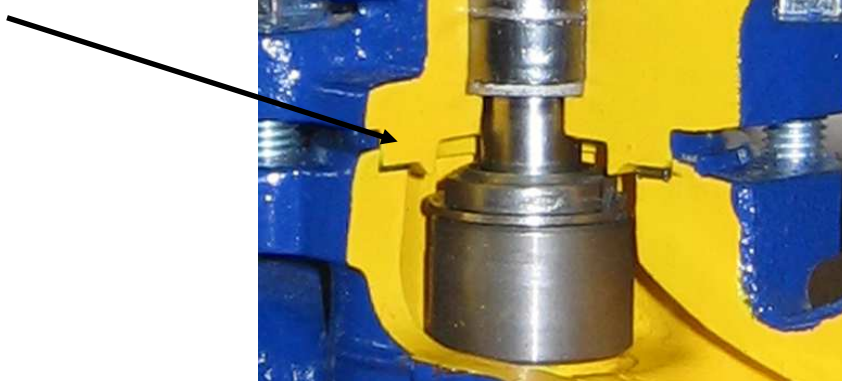

Everytime when valve bonnet was disassembled sealing surface should be cleaned. During assembly it should be applied new gasket of the same type as previously used. Body-bonnet bolt connections should be tighten when the valve is at open position. The bolts should be tighten evenly and crosswise by torque wrench.

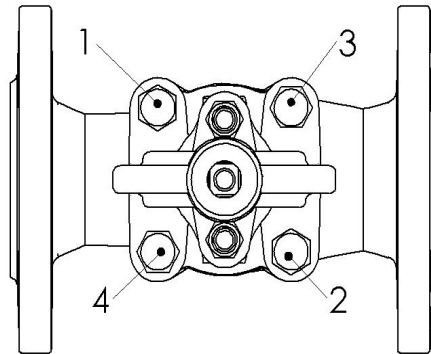

- Tightentorques

Screw	Torque
M8	15-20 Nm
M10	35 -40 Nm
M12	65 – 70 Nm
M16	140 -150 Nm

- before valves re-assembly in the pipeline it is necessary to check valve operation and tightness of all connections. Tightness test should be carried out with water pressure of 1,5 nominal pressure of the valve.

## 9.REASONS OF OPERATING DISTURBANCES AND REMEDY

- When seeking of valve malfunction reasons safety rules should be strictly obeyed

<b>Fault</b>	<b>Possible reason</b>	<b>Remedy</b>
No flow	Valve closed	Open the valve
	Flange dust caps were not removed	Remove dust caps on the flanges
Poor flow	Valve is not open enough	Open the valve
	Dirty filter	Clean or replace the screen
	Clogged pipeline	Check the pipeline
Control difficulties	Dry stem	Grease the stem
	Gland packing tighten too much	Slightly slacken gland nuts. Put attention to keep stuffing box tightness
Stem leakage	Too much loose on the gland	Tighten the gland until tightness will be reached



**armatec**

		If necessary add packing rings in stuffing box. Keep special caution.
Seat leakage	Shut off not correct	Tighten the handwheel without any auxiliary tools
	Seat or disc damage	Replace the valve and contact supplier or manufacturer
	Pressure difference too much	Apply the valve with balancing disc. Check if the valve was assembled according to arrow direction marked on the valve.
	Medium polluted with solid particles	Clean the valve. Fit strainer before the valve.
Broken connecting flange	Bolts tighten unevenly	Replace the valve with new one