

3-DELT KONTRAVENTIL MED SVEJSEENDER

TYPE 381 ISO



armatec



GENERELT

DIMENSION:	DN8 TIL DN50
TRYKTRIN:	PN63
TEMPERATUR:	-20°C TIL 200°C
MATERIALE:	SYREFAST RUSTFRIT STÅL
TILSLUTNING:	SVEJSEENDER - ISO 1127

OPTION

DIMENSION:	DN65 TIL DN100
GODKENDELSER:	EU1935

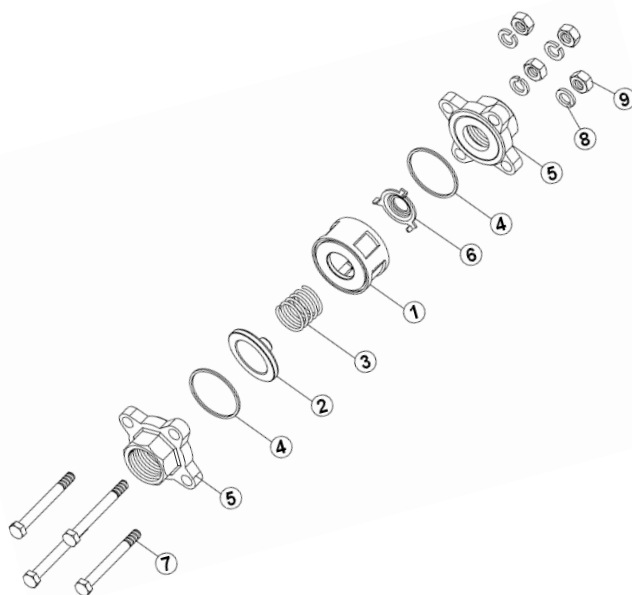

POS	BESKRIVELSE	MATERIALE
1	HUS	RUSTFRIT STÅL 1.4408
2	KLAP	RUSTFRIT STÅL AISI 316
3	FJERDER	RUSTFRIT STÅL AISI 316
4	PAKNING	PTFE
5	TILSLUTNINGSENDE	RUSTFRIT STÅL 1.4408
6	BØSNING	RUSTFRIT STÅL AISI 316
7	BOLT	RUSTFRIT STÅL A2-70
8	SKIVE	RUSTFRIT STÅL AISI 304
9	MØTRIK	RUSTFRIT STÅL A2-70

BESKRIVELSE

- **3-delt konstruktion** for nem inspektion og udskiftning af midterpart.
- **Fjederpåvirket klap** muliggør montering i alle retninger.
- **Materiale certifikat EN10204/3.1** foreligger, da der er sporbarhed på alle kontraventiler.

VELEGNET TIL



INDUSTRI



VANDVÆRKER



VARMEANLÆG



KØLEANLÆG



DAMP



BIOGAS



FØDEVARER

DIMENSIONER

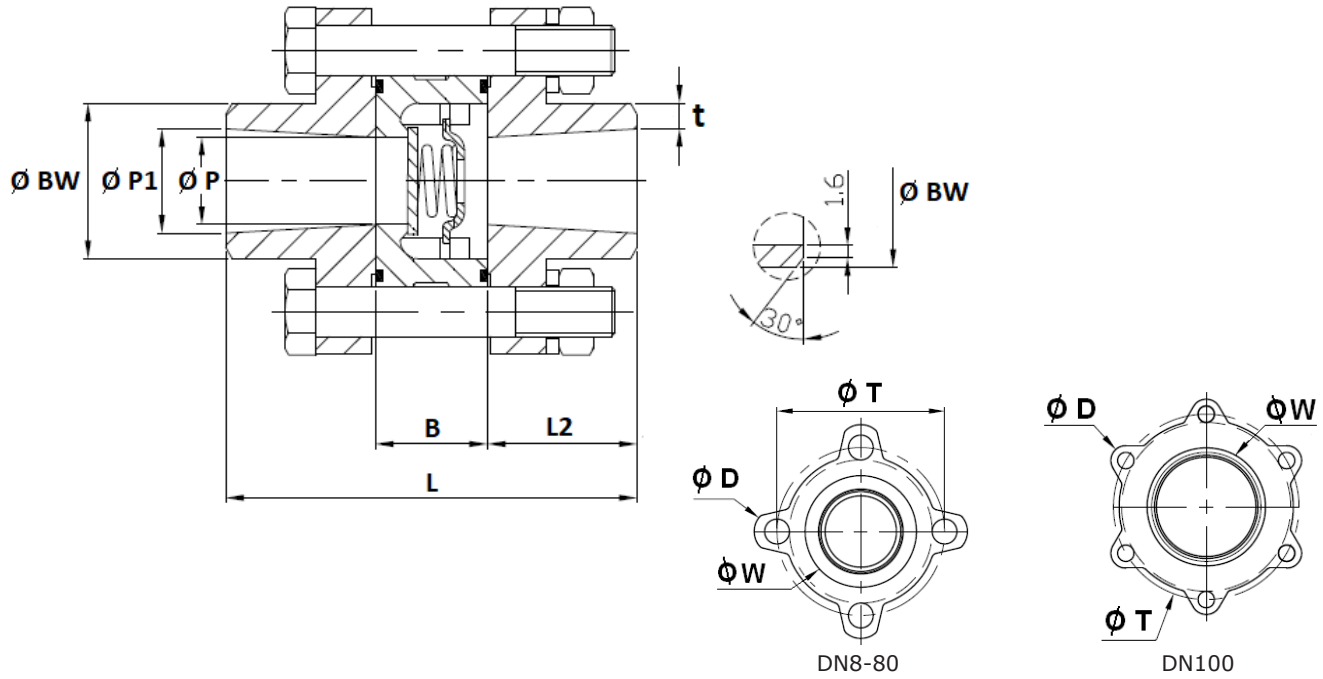

DIM [MM]	Ø P [MM]	Ø P1 [MM]	L [MM]	L2 [MM]	B [MM]	Ø D [MM]	Ø BW [MM]	t [MM]	Ø T [MM]	VÆGT [KG]
DN 8	10,0	9,5	66,0	24,0	18,0	12,0	13,5	2	36,5	0,3
DN 10	10,0	13,2	66,0	24,0	18,0	12,0	17,2	2	36,5	0,2
DN 15	15,0	17,3	67,0	24,0	19,0	14,0	21,3	2	42,7	0,4
DN 20	20,0	22,9	81,0	28,5	24,0	16,0	26,9	2	51,7	0,5
DN 25	25,0	29,7	89,5	30,0	29,5	16,0	33,7	2	58,7	0,7
DN 32	32,0	37,2	92,0	29,5	33,0	18,0	42,4	2,6	72,7	1,3
DN 40	38,0	43,1	103,5	33,0	37,5	18,0	48,3	2,6	83,7	1,7
DN 50	50,0	54,5	117,0	35,0	47,0	18,0	60,3	2,9	98,7	2,5
DN 65	65,0	70,3	131,5	42,0	47,5	18,0	76,1	2,9	129,0	4,3
DN 80	80,0	82,5	143,5	44,0	55,5	18,0	88,9	3,2	153,5	6,2
DN 100	100,0	107,9	174,5	52,0	70,5	18,0	114,3	3,2	186,5	11,0

VENTIL DATA

DIM	Åbningstryk [mbar]			Kvs [m³/h]
	↑	↓	→	
DN 8	25	21	23	1,23
DN 10	25	21	23	1,23
DN 15	25	21	23	2,24
DN 20	25	21	23	6,50
DN 25	25	21	23	9,61
DN 32	27	21	24	15,89
DN 40	29	21	25	22,49
DN 50	29	21	25	25,12
DN 65	31	21	25	57,80
DN 80	32	21	26	64,83
DN 100	33	21	27	91,60

TRYKTABSKURVE

(MEDIE: VAND 20°)

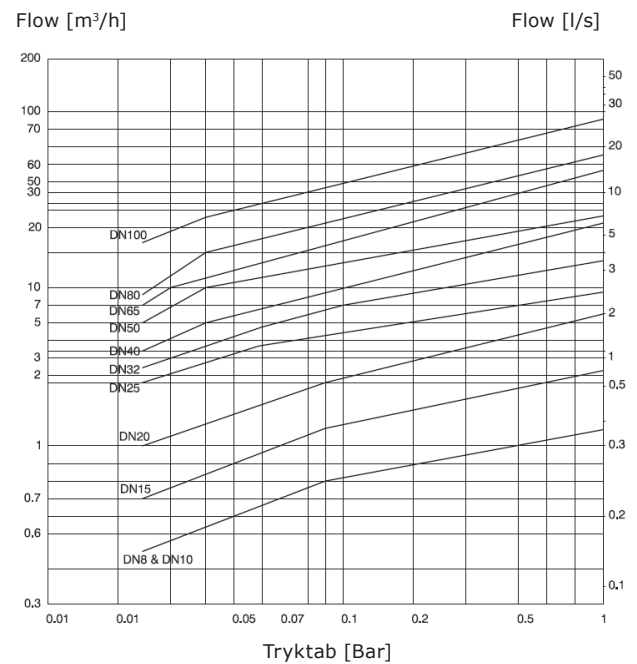

TRYK / TEMPERATUR

