

BALL VALVE WITH ISO-MOUNTING FLANGE

TYPE DVC7752 - FULL BORE



GENERAL

SIZE:	1/4" TO 3"
PRESSURE:	63 BAR
MATERIAL:	ACID-PROOF STAINLESS STEEL CF8M
THREAD:	BSPP - ISO 228/1
ISO TOP FLANGE:	ISO 5211
TEMPERATURE:	-29°C TO 200°C (TEMPERATURE DEPENDS ON PRESSURE)

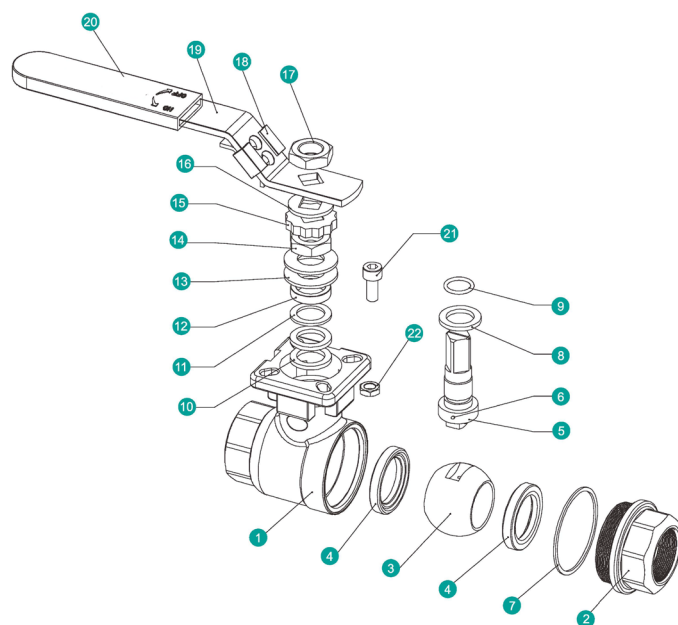

POS	DESCRIPTION	MATERIAL
1	BODY	STAINLESS STEEL CF8M
2	CONNECTION	STAINLESS STEEL CF8M
3	BALL	STAINLESS STEEL CF8M
4	SEAT	PTFE
5	STEM	STAINLESS STEEL AISI 316
6	ANTISTATIC DEVICE	STAINLESS STEEL AISI 316
7	BODY GASKET	PTFE
8	STEM PACKING	PTFE
9	O-RING	FPM
10	V-RING	PTFE
11	V-RING	50% PTFE + 50% STAINLESS STEEL
12	BUSHING	STAINLESS STEEL AISI 316
13	BELLEVILLE WASHERS	STAINLESS STEEL AISI 301
14	STEM NUT	STAINLESS STEEL A194-8
15	LOCK SADDLE	STAINLESS STEEL AISI 304
16	WASHER	STAINLESS STEEL AISI 304
17	NUT	STAINLESS STEEL A194-8
18	LOCKING DEVICE	STAINLESS STEEL AISI 304
19	HANDLE	STAINLESS STEEL AISI 304
20	HANDLE SLEEVE	VINYL
21	STOP BOLT	STAINLESS STEEL A2-70
22	STOP NUT	STAINLESS STEEL A2-70

DESCRIPTION

- **2-pcs ball valve in acid-proof stainless steel** with dynamic stuffing box in PTFE. Suitable for demanding tasks.
- **ISO 5211 top flange** makes it simple and easy to mount an actuator without bracket and coupling. A compact solution with less connections = less slack.
- **Approvals:** TA-Luft, EU1935, FDA, SIL2, ATEX 2014/34/EC (Ex II 2 G D)
- **The stem is blow-out proof**, which also gives the benefit of increasing the stem sealing when pressure rises.
- **Maintenance free stuffing box** with belleville washers. Reinforced V-rings will provide optimum packing and longer lifetime - also at various temperatures.

SUITABLE FOR

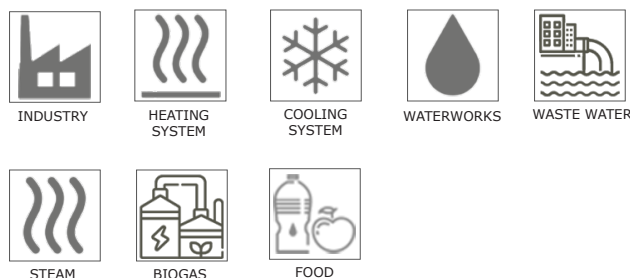

DIMENSIONS

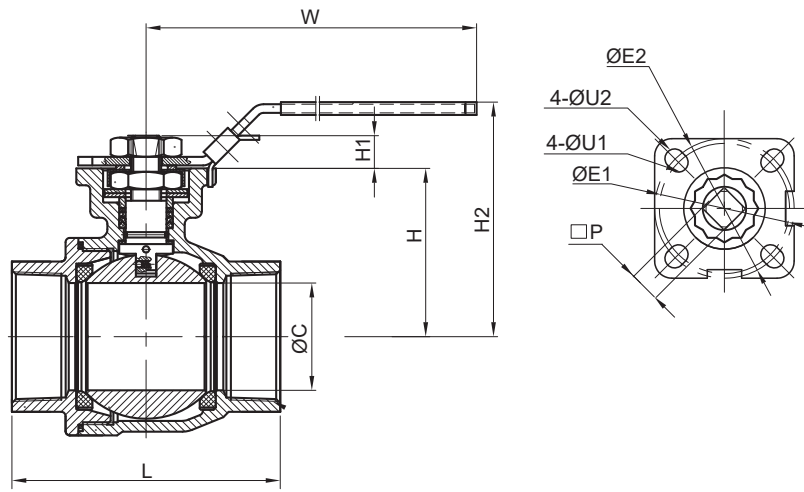

DIMENSION [INCH]	VALVE WITH HANDLE					MOUNTING FLANGE					STEM		
	ØC [MM]	L [MM]	W [MM]	H [MM]	H2 [MM]	ISO 5211	ØE1 [MM]	ØU1 [MM]	ISO 5211	ØE2 [MM]	ØU2 [MM]	P [MM]	H1 [MM]
1/4"	10.6	67	147	42.5	73	F03	36	6	F04	42	6	9	8
3/8"	12.7	67	147	42.5	73	F03	36	6	F04	42	6	9	9
1/2"	15.0	67	147	42.5	73	F03	36	6	F04	42	6	9	9
3/4"	20.0	70.4	147	49.0	79	F03	36	6	F05	50	7	9	9
1"	25.0	85.0	177	58.0	88	F04	42	6	F05	50	7	11	11
1 1/4"	32.0	94.0	177	62.5	93	F04	42	6	F07	70	9	11	11
1 1/2"	38.0	105.0	197	71.5	103	F05	50	7	F07	70	9	14	14
2"	50.0	125.0	197	78.4	110	F05	50	7	F07	70	9	14	14
2 1/2"	63.5	155.0	267	100.0	150	F07	70	9	F10	102	11	17	17
3"	76.0	173.0	267	109.0	159	F07	70	9	F10	102	11	17	17

VALVE DATA

DIMENSION [INCH]	¹⁾ TORQUE [NM]	KV-VALUE 90° [M3/H]	WEIGHT [KG]
1/4"	6.5	11	0.54
3/8"	6.5	11	0.55
1/2"	6.5	16	0.56
3/4"	7.8	31	0.62
1"	14.3	41	1.08
1 1/4"	24.7	80	1.42
1 1/2"	33.8	142	2.04
2"	49.4	178	3.27
2 1/2"	76.7	387	6.04
3"	131.3	671	9.17

¹⁾ Torque figures include 30% safety factor.

When dimensioning the actuator following must be added:

+15% with dry air and demineraliseret water.

+30% with sludge og abrasive media.

-15% with very lubricating media.

PRESSURE/TEMPERATURE

