

Float Valves

Float Valves NV 98

Universal Valve



Technical Data

Connection DN	40 - 80
Connection G	3/8A - 1 1/2A
Nominal Pressure PN	16
Operating Pressure	0 - 8 bar
K _{vs} -Value	0.5 - 82 m ³ /h
Temperature	130 °C
Medium	liquids

Description

Float valves automatically control liquid levels in sealed or open (non-pressurised) tanks and vessels without requiring external energy. The float registers the liquid level and directly controls the valve via a lever. A change in the liquid level immediately results in a changed flow volume.

NV 98 is a float valve for horizontal installation inside a tank as inlet valve with outlet at the bottom. This valve is made entirely of stainless steel featuring excellent corrosion resistance. NV 98 R (spigot connection) is fitted with a ball float, NV 98 F (flange connection) is fitted with a cylindrical float that is adjustable on its float bar. NV 98 FP is fitted with a parallel float guide which prevents oscillation of the float. The valve cone is fitted with a soft seal.

The following note applies to float valves fitted with float bars: If the liquid level is below the float bar i.e. if the float points downwards, a guide for the float bar should be installed.

Standard

- » All stainless steel construction
- » NV 98 R with ball float SC 3
- » NV 98 F with cylindrical float SC 8
- » NV 98FP with cylindrical float SC 8 and float bar parallel guide

Options

- » Various seal materials suitable for your medium
- » Special versions on request

Please state working pressure range when enquiring or ordering.

Operating instructions, know how and safety instructions must be observed. The pressure has always been indicated as overpressure. We reserve the right to alter technical specifications without notice.



illustration shows NV 98FP

K_{vs}-Values [m³/h]

pressure range bar	nominal diameter G...A					
	3/8	1/2	3/4	1	1 1/4	1 1/2
0 - 2	1.2	2.5	6	8	13.3	17.8
0 - 4	1.2	2.5	3.5	6	7.9	13.3
0 - 8	0.5	1.2	2.5	4	5	6.4

K_{vs}-Values [m³/h]

pressure range bar	nominal diameter DN			
	40	50	65	80
0 - 8	20	32	50	82

Pressure Ranges

nom. diam.	pressure range[bar]		
G 3/8 - 1	0 - 2	0 - 4	0 - 8
DN 40 - 80	0 - 8		

Float Valves

Float Valves NV 98

Universal Valve



Materials

Body	CrNiMo-steel
Cone	CrNiMo-steel
Seat	CrNiMo-steel
Valve Seal	G 3/8 FKM, G 1/2 - 1 1/2 EPDM
Float	CrNiMo-steel

Dimensions [mm] NV 98 R

size	nominal diameter G...A					
	3/8	1/2	3/4	1	1 1/4	1 1/2
A	40	40	40	45	47	47
B	60	60	60	65	72	77
C	85	85	85	90	96	101
D	ø 60	ø 60	ø 60	ø 60	ø 60	ø 60
E	110	110	110	115	123	128
F	16	16	20	20	23	25
G	3/8	3/8	1/2	3/4	1	1 1/4
H	200	200	200	200	200	200
I	125	135	155	175	205	225
K	ø 100	ø 110	ø 130	ø 150	ø 180	ø 200

Weights [kg] NV 98 R

nominal diameter G ... A						
3/8	1/2	3/4	1	1 1/4	1 1/2	
0.9	0.9	1.4	1.5	2.7	3	

Dimensions [mm] NV 98 F + NV 98 FP

size	nominal diameter DN			
	40	50	65	80
A	85	95	95	110
B	60	75	75	80
C	105	125	125	140
D	ø 70	ø 90	ø 90	ø 125
E	145	165	165	180
F	ø 43	ø 53	ø 64	ø 80
H	330	330	440	530
I	975	970	965	965
K	ø 280	ø 305	ø 340	ø 380
L	280	305	340	380
M	55	55	80	80

Weights [kg] NV 98 F + NV 98 FP

nominal diameter DN				
40	50	65	80	
6.5	9.5	12.5	13.5	

Customs Tariff Number

84818059

Special designs on request.

The pressure has always been indicated as overpressure.

Mankenberg reserves the right to alter or improve the designs or specifications of the products described herein without notice.

Dimensional Drawing

NV 98 RZ/u

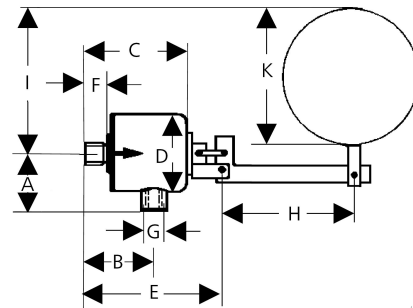

NV 98 FZ/u

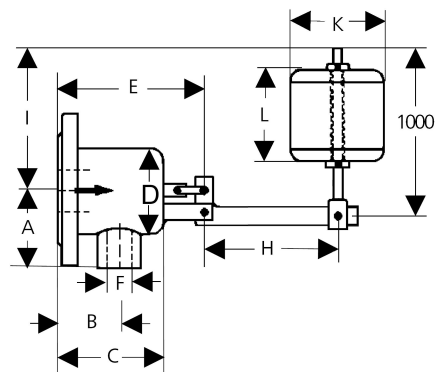

NV 98 FPZ/u

