

Features

- *State-of-the-art laser slotted metal section*
- Mounts between standard ANSI Class 150 and 300 welding neck flanges, or equivalent with same bore diameter♦
- No disk holder required
- Standard materials of construction: 316SS metal section(s), TFE seal, Non-asbestos gaskets (Other materials available)
- Operating pressures to 50% of the disk's marked burst pressure
- Temperature ratings to 500°F (260°C)
- Manufacturing range: all ARD Disks are supplied with 0% manufacturing range



Type ARD-S shown

CAUTION for installation
Additional gaskets NOT required
♦Contact ZOOK if disk is to be mounted into other style flanges

Options

- Burst Indication
- TFE Gaskets

Table 1 – ARD Series Disk Type Specifications

Disk Type	Materials of Construction	Function	Features	Nominal Thickness
ARD	Gasket/Seal/Cap/Seal/Gasket	Bi-Directional	Bursts at the specified pressure in both directions	1/8" (3.18mm)
ARD-L	Gasket/Cap/Seal/Gasket	Uni-Directional	Bursts at the specified pressure in one direction	
ARD-S	Gasket/Cap/Seal/Cap/Gasket	Bi-Directional	Bursts at two different set pressures as specified	
ARD-V*	Gasket/Cap/Seal/Support/Gasket	Uni-Directional	Bursts at the specified pressure in one direction, withstands full vacuum	

*ARD-V series disk has a non-opening vacuum support
Contact ZOOK for flow and free area specifications
Standard Gasket Material is BLUE-GARD 3000 / IFG 5500. Consult ZOOK for optional materials

Storage Tank Protection

Storage tanks are made from relatively light gauge materials. This limits their ability to contain pressure and, if they are emptied without proper venting, makes them vulnerable to collapse. ARD Disks provide simple, inexpensive protection against either condition.

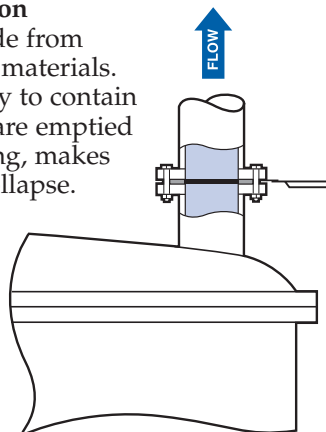

CAUTION

Disk size should be at least equal to the size of the flow inlet or outlet connection (whichever is greater) to the tank. Maximum rupture pressure should be no greater than the design pressure or vacuum (whichever is smaller) of the tank. Minimum rupture pressure should be at least double the maximum working pressure or vacuum (whichever is greater) to which the tank will be exposed.

Relief Valve Protection

Corrosive elements in the atmosphere can enter a relief valve through its outlet and attack the valve's working parts. This may prevent the valve from functioning properly. Valves with outlets connected to common headers are especially vulnerable. An ARD Disk mounted on the valve's outlet flange protects valve components from hostile environments. Consult ZOOK for guidance on applicable Code issues related to this application.

CAUTION

Disk size should be the same as the outlet flange of the valve. Maximum rupture pressure should be no greater than the set pressure of the valve. Minimum rupture pressure should be at least double the maximum working pressure in the header.

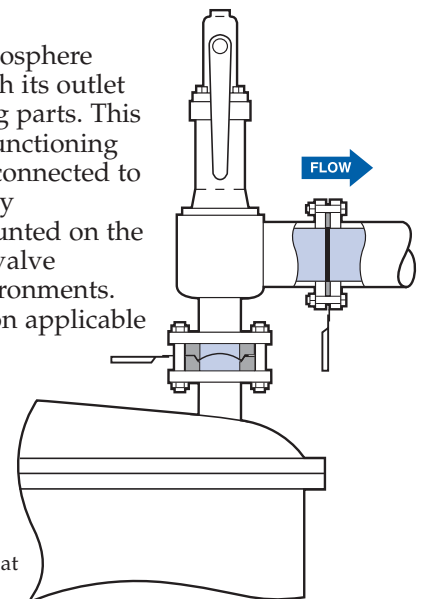

Table 2

ARD Series Minimum and Maximum Pressure Ratings
psig (bar) @ 72°F (22°C)

Disk Size	ARD-L, ARD-S, ARD-V	ARD	Maximum Burst Rating (All Types)
	Minimum Burst Rating	Minimum Burst Rating	
2"	6.00	7.00	15.00 psi (1.03 bar)
50 mm	0.41	0.48	
3"	4.00	5.00	
80 mm	0.28	0.34	
4"	3.00	3.00	
100 mm	0.21	0.21	
6"	2.00	2.00	
150 mm	0.14	0.14	
8"	1.50	1.60	
200 mm	0.10	0.11	
10"	1.25	1.25	
250 mm	0.09	0.09	
12"+	1.00	1.00	
300 mm+	0.07	0.07	
Max. Temp.	500°F (260°C)		

Table 2 – notes

- ARD Series Disks mount between standard ANSI Class 150 and 300 welding neck flanges, or equivalent with the same bore diameter. Contact ZOOK if disk is to be mounted into other style flanges
- Contact ZOOK for sizes 14" and larger

Table 3

Manufacturing Range/Burst Tolerance
psig (bar) @ 72°F (22°C)

Specified Burst Pressure	Burst Tolerance
Below 1 (Below 0.07)	± 0.33 (± 0.02)
1 to 4 (0.07 to 0.28)	± 0.50 (± 0.03)
Above 4 (Above 0.28)	± 1.00 (± 0.07)

Table 3 – notes

- 0% manufacturing range is standard. Disk will be marked with specified rating
- Burst tolerances are the maximum expected variation from the disk's marked burst pressure

United States Operations
ZOOK Enterprises, LLC
 16809 Park Circle Drive
 Chagrin Falls, OH 44022
 Toll Free **800.543.1043**
 Phone **440.543.1010**
 Fax **440.543.4930**
 E-mail **sales@zook.cc**

Canadian Operations
ZOOK Canada, Inc.
 4400 South Service Road
 Burlington, ON Can. L7L 5R8
 Toll Free **800.370.6057**
 Phone **905.681.2885**
 Fax **905.681.8838**
 E-mail **sales.canada@zook.cc**

European Operations
ZOOK Europe, LTD.
 Unit 1.14, Great House Waterside Business Park
 Redwall Close, Rotherham Road
 Dinnington, Sheffield UK. S25 3QA
 Phone **0044 (0) 1909 560999**
 Fax **0044 (0) 1909 560860**
 E-mail **zookeurope@zook.cc**



visit us on the web at www.zook.cc