

FOR USE IN EUROPE

FOR USE EXCEPT EUROPE

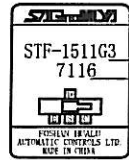

OR



CATALOG No.

MANUFACTURING No.

EXAMPLE

7 11 6  
 YEAR  
 DAY  
 MONTH 1~9: JAN. ~SEP.  
 X: OCTOBER  
 Y: NOVEMBER  
 Z: DECEMBER

(NOTICE)

- CHECK COMPATIBILITY WITH THE SYSTEM WHEN USING 4-WAY VALVES. PRESSURE RISE ON HIGH PRESSURE SIDE OR INCOMPLETE CHANGEOVER COULD BE RESULTED IN NOT COMPATIBLE.
- WHEN BRAZING, COOL THE VALVE BODY WITH WATER OR WET RAGS IN ORDER TO KEEP TEMPERATURE OF THE VALVE BODY 130°C OR LESS. (HOWEVER, DO NOT LET WATER ENTER THE INSIDE OF THE VALVE BODY.) BESIDES, MAKE SURE THAT FOREIGN MATERIALS SUCH AS OXIDE SCALE DO NOT ENTER THE INSIDE OF THE VALVE BODY. THIS COULD CAUSE INTERNAL LEAKAGE OR MALFUNCTION.
- WHEN MOUNTING THE SOLENOID COIL, THE FIXING SCREW MUST BE TIGHTENED WITH 1.47~1.96 N · M TORQUE.
- BE SURE NOT TO APPLY STRONG EXTERNAL FORCE BY IMPULSE FORCE, ETC. THIS COULD CAUSE MALFUNCTION DUE TO DEFORMATION.

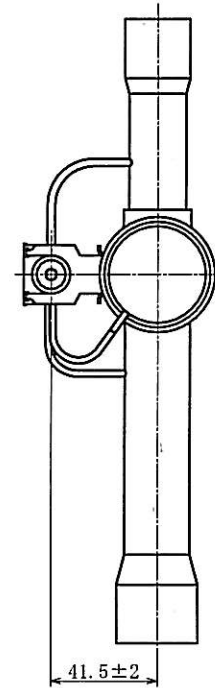
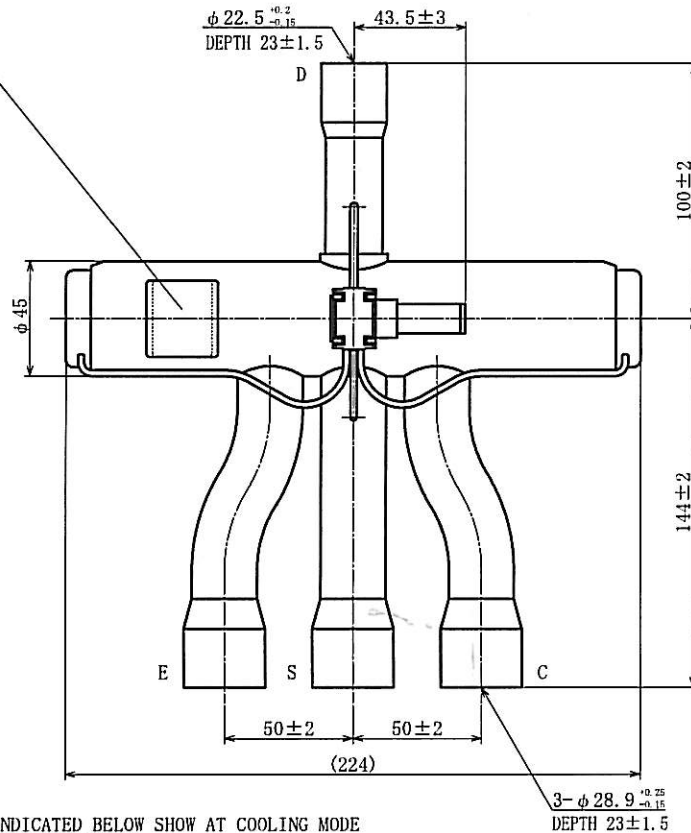

CONNECTIONS INDICATED BELOW SHOW AT COOLING MODE (WHEN COIL IS DE-ENERGIZED)

- D CONNECTION : DISCHARGE
- C CONNECTION : CONDENSER
- S CONNECTION : SUCTION
- E CONNECTION : EVAPORATOR

SPECIFICATIONS

WATER TEST PRESSURE	WITH WATER PRESSURE 6.44 MPa ( 64.4 bar)
AIRTIGHT TEST PRESSURE	WITH AIR PRESSURE 4.5 MPa ( 45.0 bar)
MAX. WORKING PRESSURE	4.5 MPa ( 45.0 bar)
CONNECTION	ILLUSTRATE
FLUID	R410A
PORT SIZE	23 mm
VALVE OPERATION	PILOT OPERATED 4-WAY REVERSING VALVE
DURABILITY	20000 TIMES TESTED BY AIR PRESSURE UNDER DISCHARGE PRESSURE 2.5MPa (25bar), SUCTION TUBE OPEN TO ATMOSPHERE AND BODY TEMP. NORMAL TEMPERATURE (LUB. OIL APPLIED DURING THE TEST)
MAX. OPERATING PRESS. DIFFERENTIAL	3.1 MPa ( 31 bar)
MIN. OPERATING PRESS. DIFFERENTIAL	0.3 MPa ( 3 bar)
VALVE LEAKAGE	6000 cm <sup>3</sup> /min. OR LESS WITH AIR UNDER 0. P. D. 1 MPa ( 10bar) AND BODY TEMP. NORMAL TEMPERATURE BUT 9000 cm <sup>3</sup> /min. OR LESS AFTER THE DURABILITY TEST.
CAPACITY	39 ~ 59 kW
MIN. OPERATING VOLTAGE *1	85% OR LESS OF RATED VOLTAGE AT 2.5MPa (25bar)
AMBIENT TEMPERATURE	-20 ~ +55 °C
ALLOWABLE FLUID TEMPERATURE	-20 ~ +120 °C
MAX. ALLOWABLE TEMPERATURE	+120 °C

MOUNTING POSITION

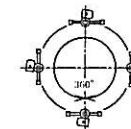

AVAILABLE TO INSTALL IN ANY POSITIONS WITH THE BODY AXIS HOLD HORIZONTALLY. 360°

AVAILABLE TO INSTALL IN ANY POSITIONS WITH THE BODY AXIS VERTICALLY AND THE SOLENOID COIL LOCATED ABOVE THE CENTER OF THE VALVE. 360°

\*1 MIN. OPERATING VOLTAGE IS SHOWN IN COIL SPECIFICATION DRAWING

WE MANUFACTURE THE PRODUCT BASED ON THE SPECIFICATIONS DESCRIBED IN THIS DRAWING. PLEASE CHECK THE SAFETY AND VALIDITY IN THE PRODUCT DESIGN IN CONSIDERATION THAT THE PRODUCT IS CONFORMED TO THE SYSTEM OR NOT WHEN USING.

Approved by	Date	Name	
	JULY. 11. 2006	4-WAY REVERSING VALVE BODY	
Designed by	Scale	Catalog Number	Drawing Number
	1:2	STF-1511G3	N-HV-23008
Drawn by	<b>SAGINOMIYA SEISAKUSHO, INC.</b>		