



Braukmann CBU140

Compact Booster Unit - single pump
To ensure the quality of potable water
according to EN 1717

APPLICATION

Fully automatic, ready-for-connection compact booster unit consisting of a single pump unit and a buffer tank for hygienic separation of drinking water and liquids of category 5 (agricultural businesses, slaughter houses, biological laboratories, sub-surface sprinkling systems) according to EN 1717.

The system has a mechanical float valve at the inlet and can be switched on and off as required. The compact construction allows for installation in narrow supply rooms. The system comes ready to plug in and is equipped with a pump control and a pressure gauge.

A membrane-based pressure expansion vessel to reduce the frequency of operation is included in delivery, it must be installed at the outlet pipework as indicated on the diagram below. The compact booster unit provides separation of category 5 liquids from drinking water supply according to EN 1717.

APPROVALS

- DVGW
- CE
- VA



SPECIAL FEATURES

- Pre-assembled, ready for installation
- No risk of microbial contamination due to hygienic separation of drinking water from non-drinking water
- Easy installation due to modular construction and draining with integrated siphon trap
- Reliable operation due to buffer tank

TECHNICAL DATA

Media	
Medium:	Water Without aggressive, abrasive and solid components
Flow rate:	up to 4 m ³ /h, 1.1 l/s
Pumping head:	up to 43 m
Pressure values	
Switch-on pressure pumps:	2.5 bar
Max. System pressure p _d :	6 bar
Max. inlet pressure:	4 bar
Operating temperatures	
Max. medium temperature:	35 °C
Specifications	
Inlet flow at 4 bar:	< 1 l/s
Supply voltage:	230 V AC ± 10%, 50 Hz

Specifications	
Power consumption in stand-by mode:	2.5 - 3 W
Max. power consumption:	800 W
Drive:	Single-phase, a.c. motor 230V, with built-in circuit protector Direct online starting Thermal class F
Protective class:	IP44
Weight CBU without water:	approx. 22 kg
filled with water:	approx. 35 kg
Weight membrane pressure expansion vessel	
without water:	approx. 2.4 kg
filled with water:	approx. 5 kg

CONSTRUCTION

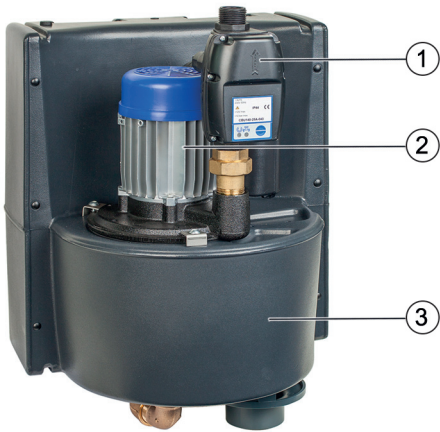
Overview	Components	Materials
	1 Monitoring and control unit for the centrifugal pump	-
	2 Self-priming multi-stage centrifugal pump	-
	3 Inlet tank with integrated drinking water inlet via mechanical float valve and free outlet according to EN 1717	PE-LLD
Not depicted components:		
	Fastening set for wall mounting, consisting of screws, wall plugs and mounting bracket	Zinkplated steel
	Flexible expansion joint connection PN10 with DVGW-/TÜV approval and 10-year guarantee for the pressure side as well as the drinking water connection (length approx. 30/50 cm)	Stainless steel
	Membrane pressure expansion vessel	Steel

METHOD OF OPERATION

The self-priming system draws in the pumping medium from an angular tank via the inlet. In this tank there is a water storage of approx 13 Litre, which is automatically filled and refilled from the drinking water network via inlet float valve.

The pump is controlled via a pressure switch within the controller at the outlet, it maintains the set pressure by switching the pump during a draw off. The factory setting on the pressure switch is 2.5 bar and the pump over runs for 10 seconds during each operation to reduce the number of on/off cycles. The device is protected from dry running, it had a check valve in line to prevent backflow into the pump and a pressure gauge indicates the outlet pressure.

TRANSPORTATION AND STORAGE

Keep parts in their original packaging and unpack them shortly before use.

The following parameters apply during transportation and storage:

Parameter	Value
Environment:	clean, dry and dust free
Min. ambient temperature:	5 °C
Max. ambient temperature:	40 °C
Max. ambient relative humidity:	50 % *

*non condensing

INSTALLATION GUIDELINES

Setup requirements

- Install shut-off valves
- Use flexible pressure hoses for connection with the pipelines (included in scope of delivery)
- The installation location should be protected against frost and be easily accessible
- Install membrane pressure expansion vessel downstream of the CBU in an upward position
- If the supply pressure exceeds 4 bar, a pressure reducer has to be connected
- Check pump flow and inlet flow rates – if necessary, install a resistance at the outlet to avoid activation of the dry running protection (for detailed information see the installation instruction)

Installation Example

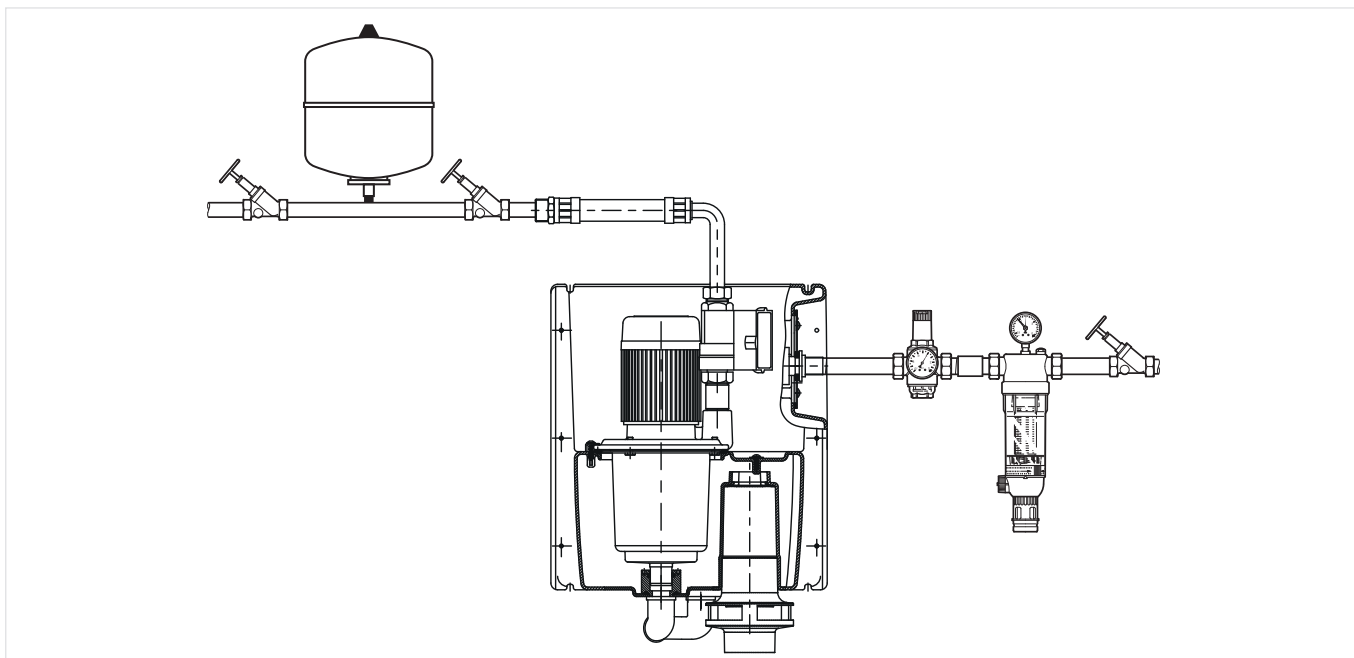

Fig. 1 Installation example of the CBU Compact Booster Unit

Indicators provided by the LEDs on the pump control unit

- Green - operational availability
- Red - Lack of water or a fault

TECHNICAL CHARACTERISTICS

Pressure drop characteristics

Pump Output

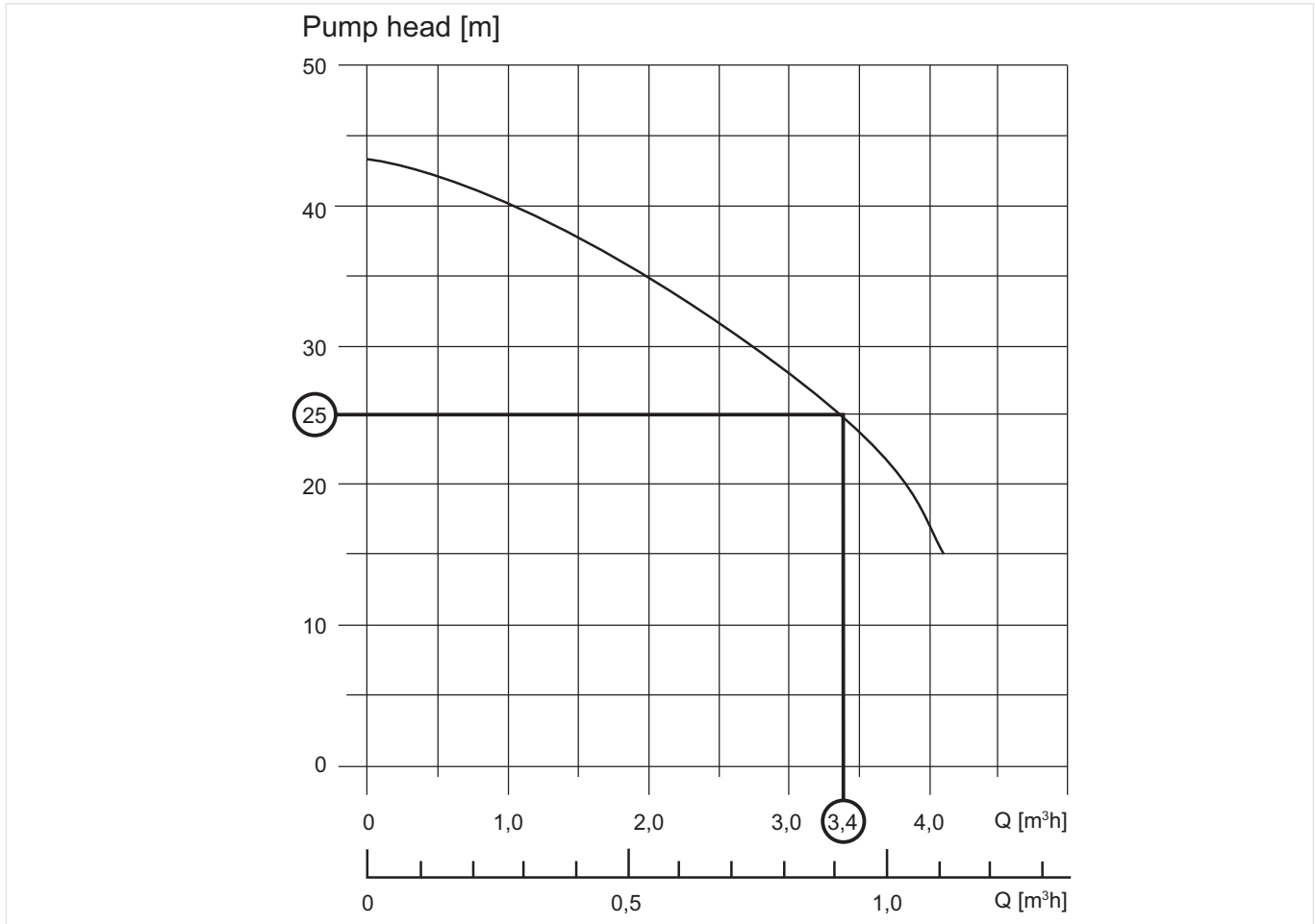

Flow characteristics of the inlet valve

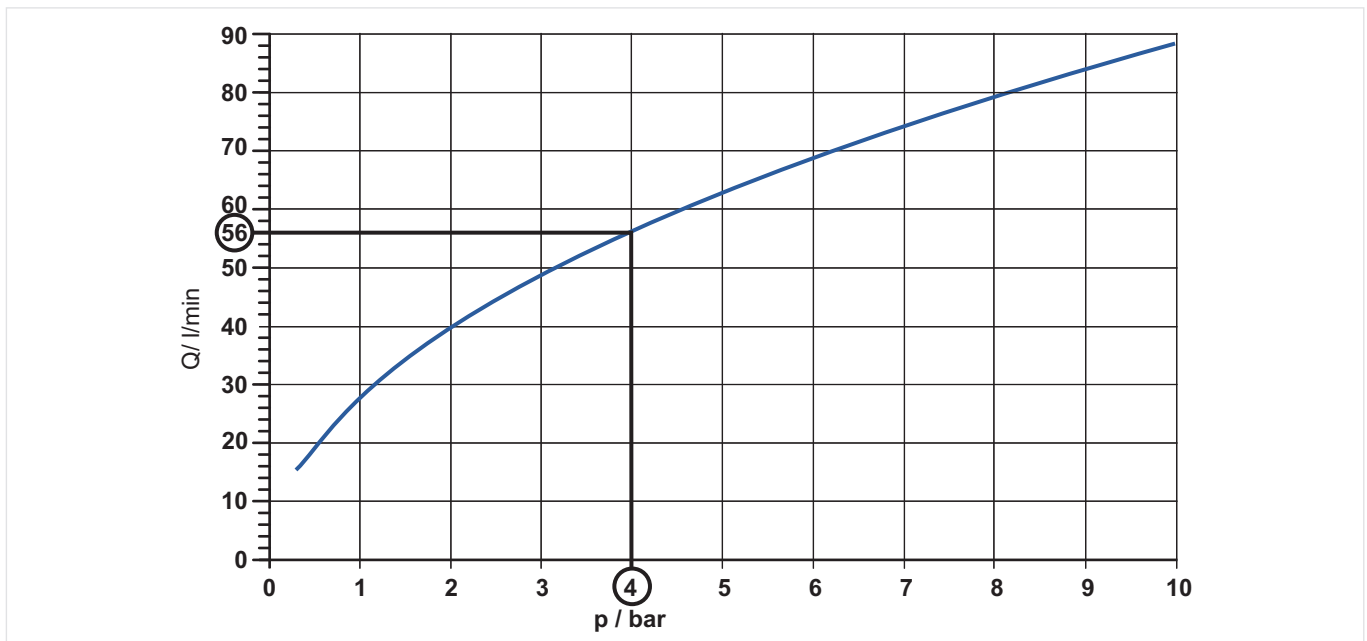

Noise expectancy values

Noise levels based on the systems pumping data result in nearly 55 dB(A).

Installation type

Fixed Installation

DIMENSIONS

CBU

Overview

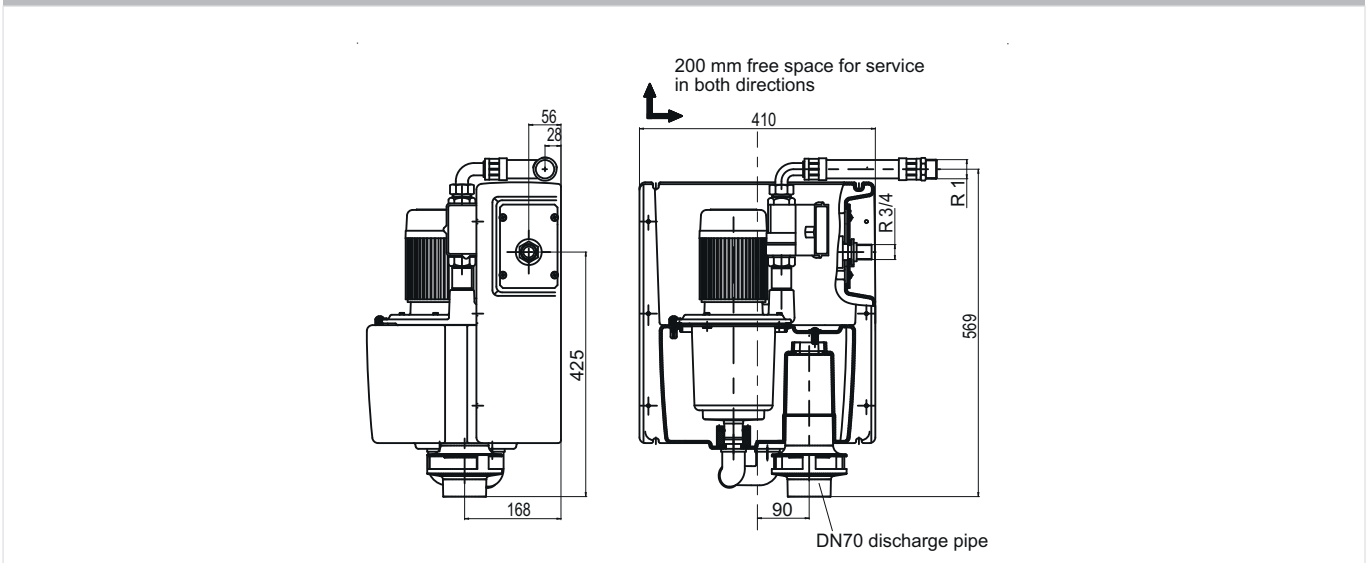

Membrane pressure expansion vessel

Overview

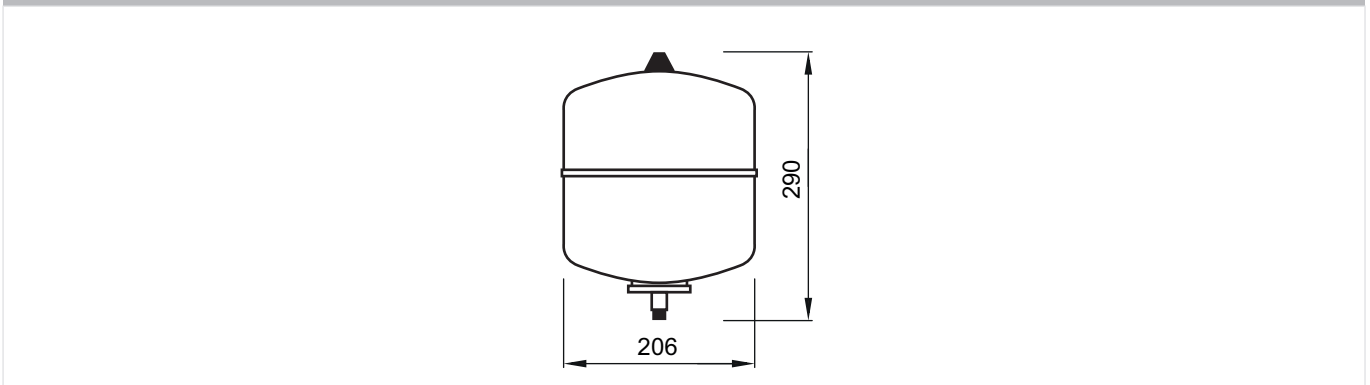

ORDERING INFORMATION

The following tables contain all the information you need to make an order of an item of your choice. When ordering, please always state the type, the ordering or the part number.

Options

CBU140-25A-043 Connection size DN25, Pumping head 43 m

Spare Parts

Compact Booster Unit / single pump CBU140, from 2013 onwards

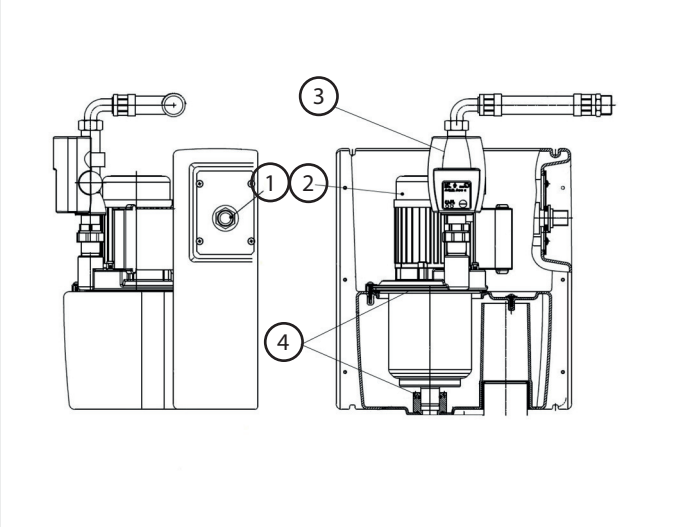
Overview	Description	Dimension	Part No.
	1 Float valve (complete)		18040893-CBU
	2 Pump incl. set of seal elements		18041119-CBU
	3 Pump control unit		18041125-CBU
	4 Seal set		18040824-CBU



Manufactured for
and on behalf of
Pittway Sàrl, Z.A., La Pièce 4,
1180 Rolle, Switzerland
by its authorised representative
Ademco 1 GmbH

For more information
homecomfort.resideo.com/europe
Ademco 1 GmbH, Hardhofweg 40,
74821 MOSBACH, GERMANY
Phone: +49 6261 810
Fax: +49 6261 81309