

Braukmann CBU142/CBU142FU

Compact Booster Unit - single pump

To ensure the quality of drinking water according to EN 1717

Application

Fully automatic, ready-for-connection compact booster unit in modulating installation consisting of a tank, free outlet Type AB and vertical high pump head.

For separation of drinking water and liquids of category 5 according to EN 1717.

The modular design makes it possible to disconnect modules for installation in buildings with limited space.

The membrane pressure vessel approved for drinking water positioned on the pressure side as control tank, direct flow in accordance with DIN 4807-5.

Special Features

- Corrosion resistant by use of high-quality stainless steel
- Compact design, space-saving
- Highest protection level for category 5 fluids
- Easy and quick commissioning because of pre-assembled, ready for installation and tested unit
- No risk of microbial contamination due to hygienic separation of drinking water from non-drinking water
- Hygienically non-hazardous materials acc. UBA, KTW and W270
- Design base plate
- Switch on is pressure-dependent, Switch off is flow-dependent
- Visualisation of functions/disturbance by LED's
- Reset-function

Technical Data

Media	
Medium:	Industrial water Cooling water Liquids which do not attack the materials chemically and mechanically. max. +30 °C
Flow rate: CBU142 (ON/OFF) CBU142FU	up to 8 m ³ /h, 2.22 l/s
Max. pumping head: CBU142 (ON/OFF) CBU142FU	76 m 70 m
Connections/Sizes	
Connection sizes:	R 1 ¹ / ₄ " - DN32 (suction - pressure side)

CBU142 (On/Off)



CBU142FU



Pressure values	
Max. inlet pressure:	8 bar
Max. pump pressure: CBU142 (ON/OFF) CBU142FU	8 bar (80 m) 6.5 bar (65 m)
Specifications	
Actuator:	1-Phase-alternating current (AC) motor
Supply voltage:	230 V, 50 Hz
Protection class: CBU142 (ON/OFF) CBU142FU	IP55
Thermal class:	F
Power:	1.5 kW (P _N)
Current consumption:	9.0 A
Empty weight: CBU142 (ON/OFF): CBU142FU:	81 kg 100 kg
Effective volume:	100 litre
Automation: CBU142 (ON/OFF) CBU142FU	Switching device, Pressure-dependent switching on and flow-dependent switching off Single-phase frequency inverter, motor-mounted, Pressure-dependent switch-on and switch-off

Construction

Overview	Components	Materials
<p>CBU142 (ON/OFF)</p> <p>CBU142FU</p>	1 Tank	LLDPE compounded
	2 Pump housing	Stainless steel
	3 High-pressure pump	1.4301 (Pump shroud); Pump Casing; Stage casing; Discharge cover
	4 Pump control unit	-
	4a Expansion vessel	Connection made of stainless steel Flow armature according to DIN 4807-5
	5 Base frame	Steel, powder-coated blue
	6 Pipeline	Ms-red bronze/Chrome-plated steel
7 Frequency converter 230 V		
Not depicted components:		
Hydraulic system	Stainless steel	
Seal	EPDM	
Slide bearing	Aluminium oxide	
Floating ring seal	acc. to EN 12756	
Floating ring	Silicon carbide	
Counter ring	Hard coal	
Elastomer	EPDM	
Diaphragm	Suitable for drinking water	

Transportation and Storage

Keep parts in their original packaging and unpack them shortly before use.

The following parameters apply during transportation and storage:

Parameter	Value
Environment:	clean, dry and dust free
Min. ambient temperature:	0 °C
Max. ambient temperature:	
CBU142 (ON/OFF)	+40 °C
CBU142FU	+30 °C
Max. ambient relative humidity:	85 % *

*non condensing

Method of Operation

The self-priming system draws in the pumping medium from an angular tank via the inlet. In this tank there is a water storage of approx. 100 liters, which is automatically filled and refilled from the drinking water network via inlet float valve.

CBU142-32A-065 (on/off)

The pump is controlled via a pressure switch within the controller at the outlet, it maintains the set pressure by switching the pump during a draw off. The factory setting on the pressure switch is 2.5 bar and the pump over runs for 10 seconds during each operation to reduce the number of on/off cycles. The device is protected from dry running.

CBU142FU-32B-065N (frequency controlled)

A fully automatic control switches the pump unit on and off depending on the pressure. If the preset pressure is not reached, the frequency converter controls speed of the pump and generates a constant pressure.

When the consumption decreases and the pressure rises above the set point, the pump switches off. The connection for the dry run protection is designed as a digital input. If the connection is open, the control switches the safety isolating station off after approx. 10 seconds (factory setting).

Both systems the CBU142 and the CBU142FU comprise one multi-speed high-pressure rotary pump with inlet shut-off valve. The check valve on the pumping side prevents liquid from backing up on the pump and flowing backwards through it, and it relieves the floating ring seal.

The fully automatic Compact Booster Units with compact design comprising:

CBU142-32A-065 (on/off)	CBU142FU-32B-065N (frequency controlled)
Vertical high-pressure pump Movitec VE 6/08	Vertical high-pressure pump Movitec VE 6/07
Pump control: Brio 2000 with vertical outlet to the top	Pump control: Nastec MIDA (frequency control driven) pressure sensor: WIKA 0-10 (5)
Flow rate of 6.0 m ³ /h at 6.0 bar	Flow rate of 6.0 m ³ /h at 5.6 bar
Electro-mechanical control unit to ensure the required supply pressure is provided for the consumers	Frequency control driven unit for constant pressure

Technical Characteristics

Pressure drop characteristics

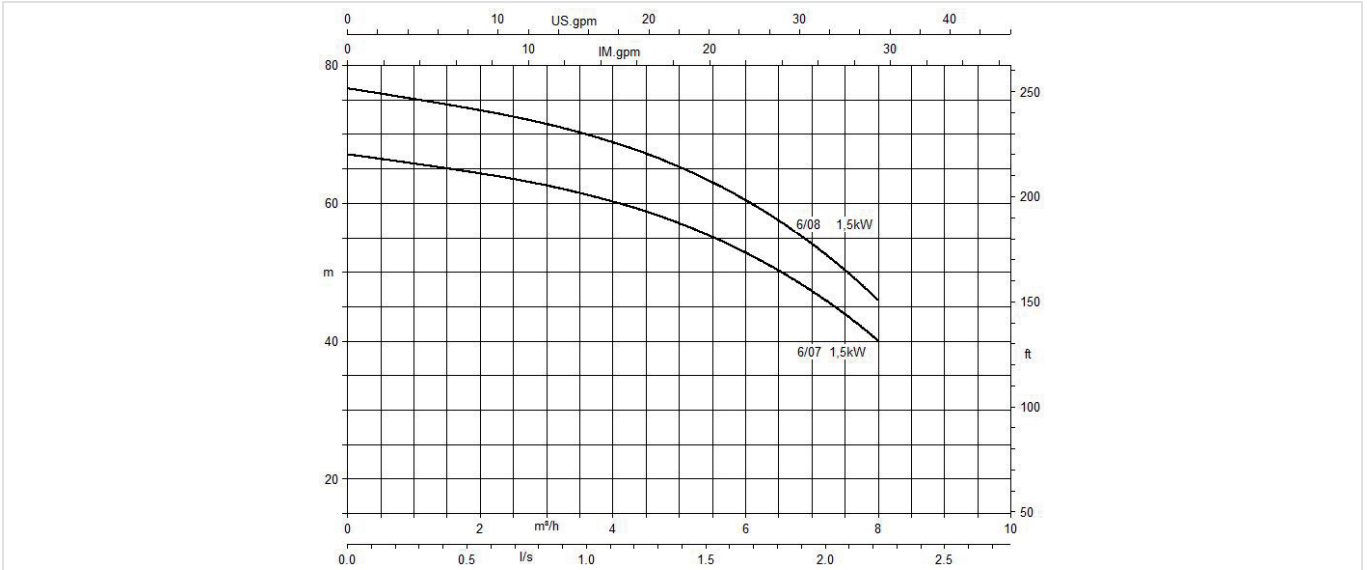

Dimensions

Overview

CBU142 (ON/OFF)

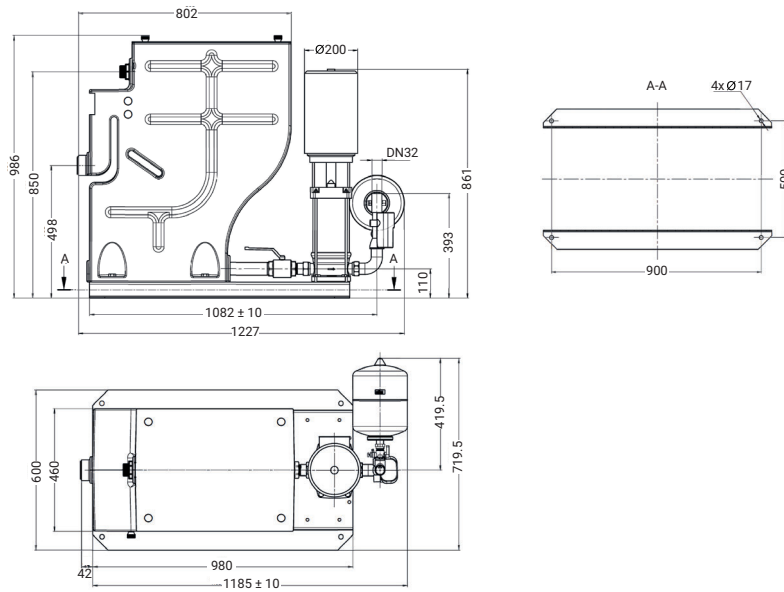

CBU142FU

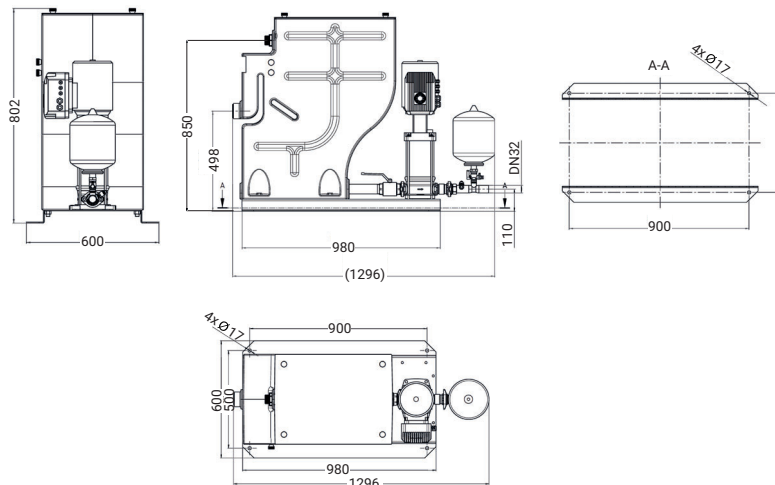



Note: All dimensions in mm unless stated otherwise.

Ordering Information

Ordering Number: CBU142-32A-065 (on/off)

Ordering Number: CBU142FU-32B-065N (frequency controlled)

Accessories

	Description	Dimension	Item No.
	Feet set		FEETSET-CBU142
	Sensor holder		SENSHOLD-CBU142
	Sensor	3 m	SENSOR-CBU142

Spare Parts

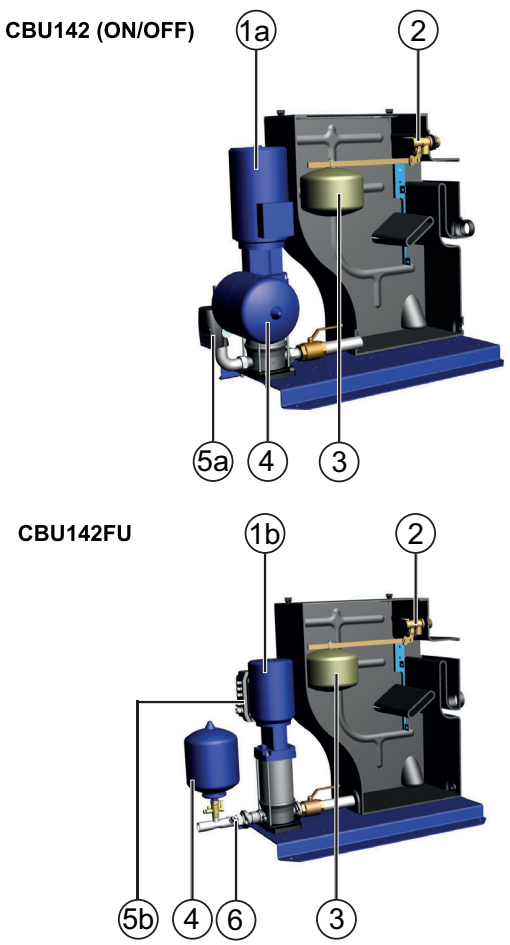
Overview	Description	Dimension	Item No.
 <p>CBU142 (ON/OFF)</p> <p>CBU142FU</p>	1a Pump Movitec 6/08		PUMP-CBU142
	1b Pump Movitec 6/07		PUMP-CBU142FU
	2 Float valve		VR170-11/4A
	3 Float stainless steel		ZN170-11/2A
	4 Membrane buffer tank 8l		VESSL-CBU142
	5a Pump control BRIO 2000		PUMPCONT-CBU142
	5b Frequency converter		FU-CBU142
	6 Pressure Transmitter		PRTR-CBU142FU

resideo

Ademco 1 GmbH, Hardhofweg 40,
74821 MOSBACH, GERMANY
Phone: +49 6261 810

Manufactured for and on behalf of
Pittway Sàrl, Z.A., La Pièce 6,
1180 Rolle, Switzerland

Subject to change. EN0H-1382GE23 R0723
© 2023 Resideo Technologies, Inc.
All rights reserved.

For more information
resideo.com

This document contains proprietary information of Pittway Sàrl and its affiliated companies and is protected by copyright and other international laws. Reproduction or improper use without specific written authorization of Pittway Sàrl is strictly forbidden.