

Busmodul - Ethernet

GB Operating manual

Original operating manual

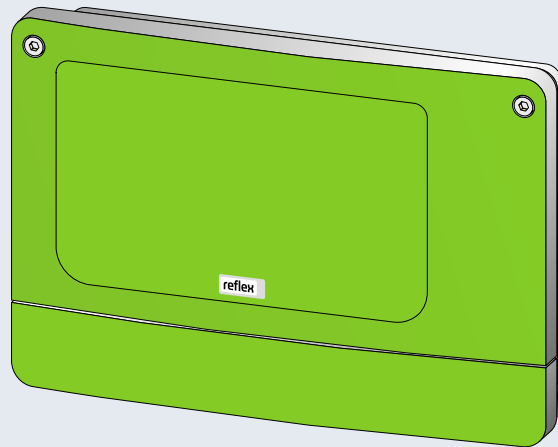

- 1 **Notes on the operating manual**4
- 2 **Models**.....4
- 3 **Technical data**5
- 4 **Connection**6
 - 4.1 RS-485 interface 8
 - 4.2 Ethernet plug..... 9
- 5 **Settings**10
 - 5.1 Terminators of the RS-485 interface10
 - 5.2 Network settings.....11
 - 5.3 Network settings.....12
 - 5.4 Setting the IP address with APR assignment.....13
 - 5.5 Setting the IP address with the DIP switches14
 - 5.6 Network settings using a web browser15
- 6 **Modbus/TCP**16
- 7 **Operating state display on the web browser**19
- 8 **Diagnosis**20
- 9 **Replacing the fuses**.....22
- 10 **Firmware update**.....23
- 11 **DIP switch**25
- 12 **Annex**26
 - 12.1 Reflex Customer Service26

1 Notes on the operating manual



Notice!

Every person installing this equipment or performing any other work at the equipment is required to carefully read this operating manual prior to commencing work and to comply with its instructions. The manual is to be provided to the device operator and must be stored near the device for access at any time.

2 Models

A Modbus/TCP master uses the "Ethernet" bus module to read the operating state of the Reflex controller. This state can be displayed in a web browser. An RS – 485 interface connects the controller to the bus module.

Two connection options are provided:

- Standard (R-S-I Art.No. 003544)
 - The bus module assumes the "master function" on the RS-485 interface to the controller and retrieves the data.

This variant is used only when the "network interface" (S1) is used to connect the bus module to the controller.

- Module bus interface version (R-S-I Art.No. 003548)
 - The controller assumes the "master function". The bus module works as an "I/O module" and is cyclically polled by the controller.

This variant is used when the bus module is connected to the "Control Touch" controller at the S2 module bus interface of Control Touch (in parallel to the main circuit board).



Note!

You use a DIP switch to select the mode, see chapter 11 "DIP switch" on page 25 .

3 Technical data

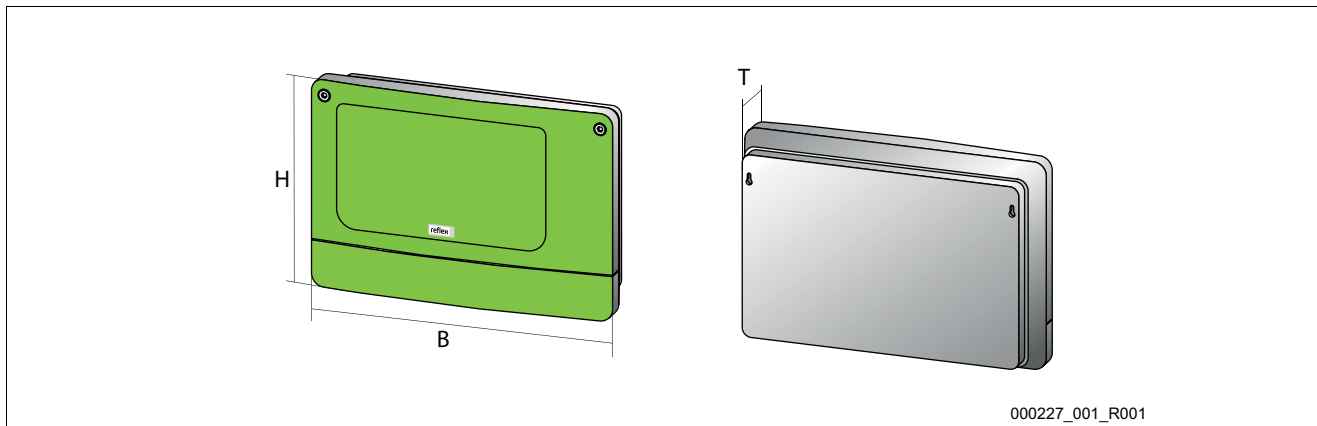

000227_001_R001

Housing	Plastic housing
Width	340 mm
Height	233.6 mm
Depth	77 mm
Weight	2.0 kg
Permissible operating temperature	-5° C – 55° C
Permissible storage temperature	-40° C – 70° C
Degree of protection IP	IP 64
Voltage supply	230 V AC, 50 – 60 Hz (IEC 38)
Fuses	
• primary	0.25 A
• secondary	0.8 A
Ethernet interface	<ul style="list-style-type: none"> • 10 Base – T or 100 Base – Tx with automatic detection • RJ 45 connection
Interface to the controller	<ul style="list-style-type: none"> • RS – 485 or RS – 232 • 19.2 kbit/s • Floating • Connection with plug-in screw terminals • RSI-specific protocol

4 Connection



Danger – electric shock!

- Risk of serious injury or death due to electric shock.
 - Ensure that the system is voltage-free before installing the device.
 - Ensure that the system is secured and cannot be reactivated by other persons.
 - Ensure that installation work for the electric connection of the device is carried out by an electrician, and in compliance with electrical engineering regulations.

The bus module is shipped with a power cable including earthed plug as standard. If required, you may use a different power cable. Proceed as follows:

1. Pull the power plug from the device.
2. Open the housing cover.

The connection terminals are underneath the housing cover.

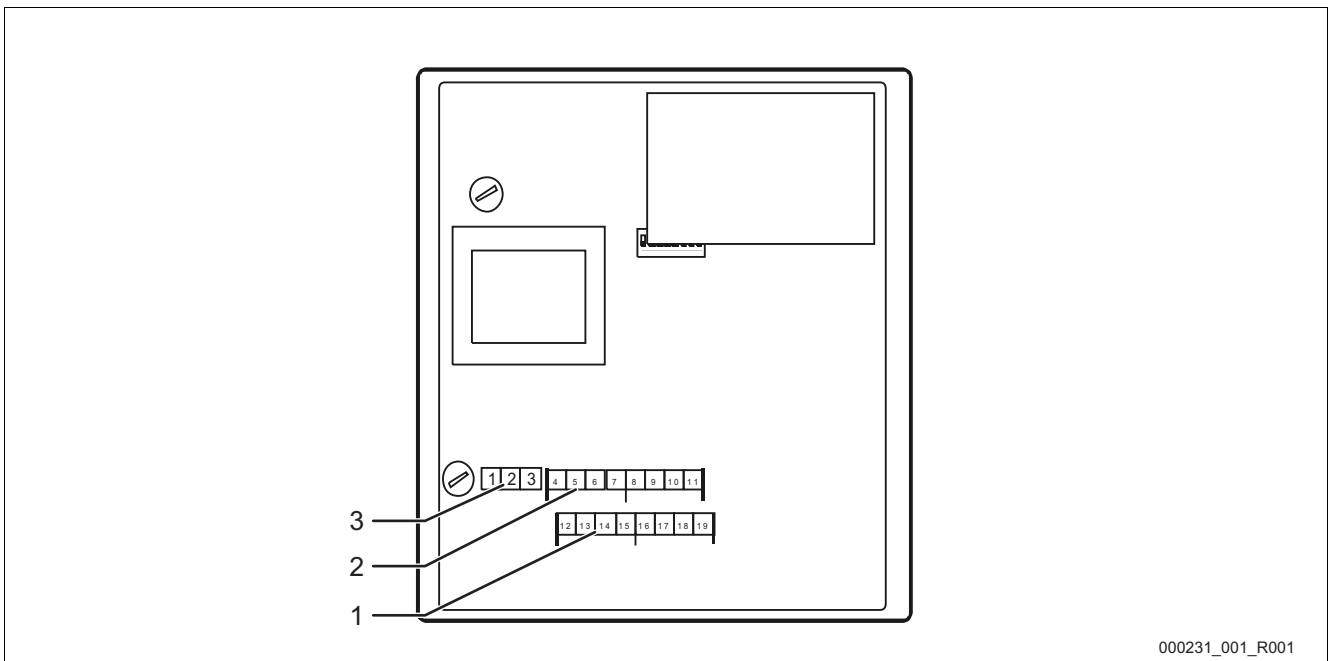

No.	Component
1	COM 1 RS-232 interface
2	COM 1 RS-485 interface

No.	Component
3	Power supply 230 V

Terminal number	Signal	Function	Wiring
Power supply for the bus module			
1	L	Supply 230 V, maximal 16 A	On-site
2	N		
3	PE		
Interfaces for the bus module			
4	Signal A (+)	COM 1 RS-485 interface to the controller	User-supplied
5	Signal B (-)		
6	Signal ground		
7	Shielding (optional)		
8	--	COM 2 RS-485 interface – Currently not used	--
9	--		
10	--		
11	--	COM 1 RS-232 interface	User-supplied
12	"RX" signal conductor for outgoing data		
13	"TX" signal conductor for incoming data		
14	"GND" signal ground		
15	Shielding	COM 2 RS-232 interface – Currently not used	--
16	--		
17	--		
18	--		
19	--		

4.1 RS-485 interface



Caution – Device damage!

- Using an incorrect bus module may cause the destruction of the interface drivers.
 - Ensure the use of a correct bus module.

Proceed as follows:

- Provide the correct bus module.
- Use a shielded cable to connect the interfaces to terminals 4 to 7 of the main circuit board.
 - Use a three-wire conductor as the interface is floating.
- Install a terminator at both ends of an RS-485 network.
 - Activate the terminators.



Note!

Upon request, the Reflex Customer Service will provide the following information, see chapter 12.1 "Reflex Customer Service" on page 26 .

- RS-485 interface protocol.
- Connection details.
- Details about the optional communication modules.

4.2 Ethernet plug



Danger – electric shock!

- Risk of serious injury or death due to electric shock.
 - Ensure that the system is voltage-free before installing the device.
 - Ensure that the system is secured and cannot be reactivated by other persons.
 - Ensure that installation work for the electric connection of the device is carried out by an electrician, and in compliance with electrical engineering regulations.

The Ethernet is not connected to the motherboard but directly at the Ethernet plug-in module.

Proceed as follows:

1. Open the housing cover.
2. Connect the RJ45 plug to the Ethernet connection.
 - In the case of a cable entry with water spray protection, feed the Ethernet cable without the RJ45 plug through the screwed cable gland and then attach the RJ45 plug.

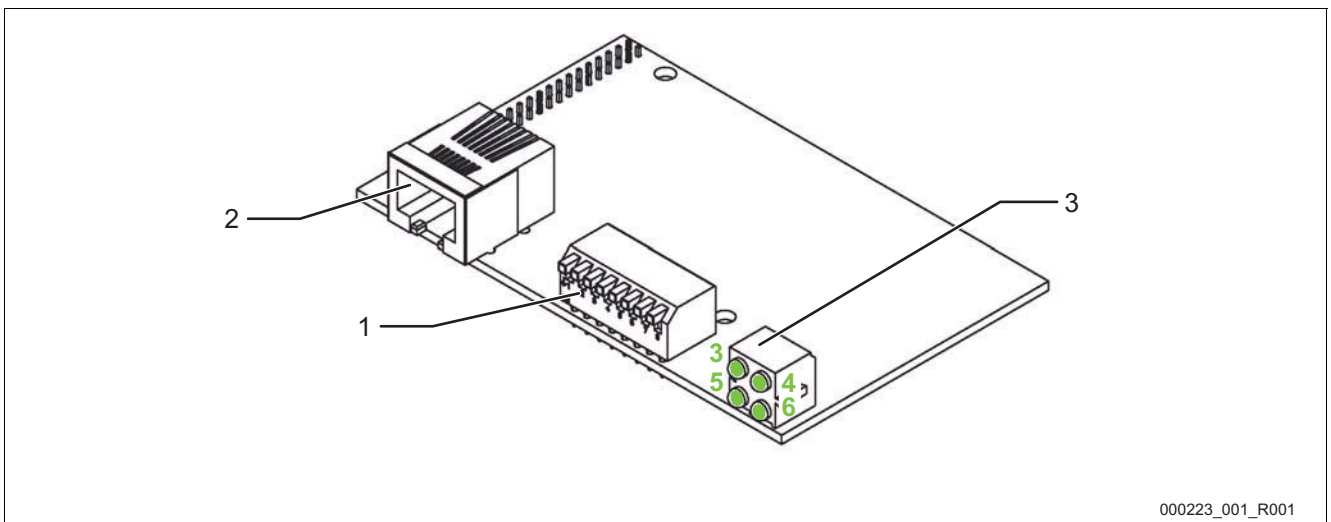

000223_001_R001

No.	Component
1	DIP switch
2	Connection for the RJ45 plug

No.	Component
3	Light emitting diodes

5 Settings



Danger – electric shock!

- Risk of serious injury or death due to electric shock.
 - Ensure that the system is voltage-free before installing the device.
 - Ensure that the system is secured and cannot be reactivated by other persons.
 - Ensure that installation work for the electric connection of the device is carried out by an electrician, and in compliance with electrical engineering regulations.

5.1 Terminators of the RS-485 interface

You must activate or deactivate the terminators at both ends of an RS-485 network.

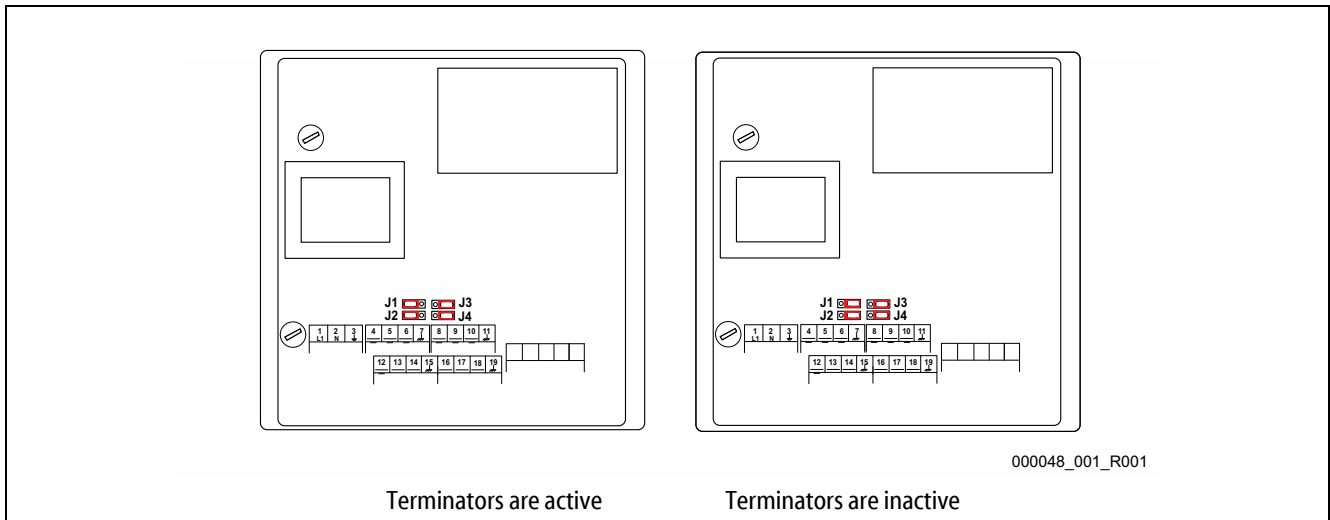

Select the setting:

- Active setting of the terminators.
 - The bus module is installed at the beginning or the end of the RS – 485 network.
 - For long conductors.
- Inactive setting of the terminators.
 - The bus module is not placed at the beginning or the end of the RS – 485 network.
 - A short conductor directly connects the bus module with the controller.
 - Use of more than two devices.

Proceed as follows:

1. Pull the power plug from the bus module.
2. Open the housing cover.
3. Select the required setting.
 - Jumper J1 and J2 installed at the left side.
 - The terminators are active.
 - Jumper J1 and J2 installed at the right side.
 - The terminators are inactive.

The setting process for the terminators is completed.



Note!

- The COM2 interface is inactive.
- The jumpers (J3-J4) are not functional.

5.2 Network settings

You must set the network in order for the Ethernet bus module to be functioning. These network settings are required:

- IP address.
 - Ask your network administrator for a free IP address.
- Subnet mask.
 - Ask your network administrator for the required settings.
- Gateway IP address.
 - Ask your network administrator for the required settings.

You have two options to set the network:

- Manual set-up.
- Automatic set-up, see chapter 5.3 "Network settings" on page 12 .
 - Use a DHCP Server.

Proceed as follows to manually set up the network:

- ARP assignment of the IP address to a PC.
 - ARP assignment is only possible for IP addresses with the 192.168.0.xxx format.
 - Use the DIP switches to set the IP address.
 - Gateway is not supported.
- Set-up with an integrated web server.
 - This method is not suitable for the initial setting of the IP address, because the IP address must be set before you can open the website.
 - Setting the IP address on the website "<http://<IP Address>/nwconfig.html>".



Note!

For automatic set-up, you need the bus module MAC address which is located on a label on the outside of the bus module.

5.3 Network settings

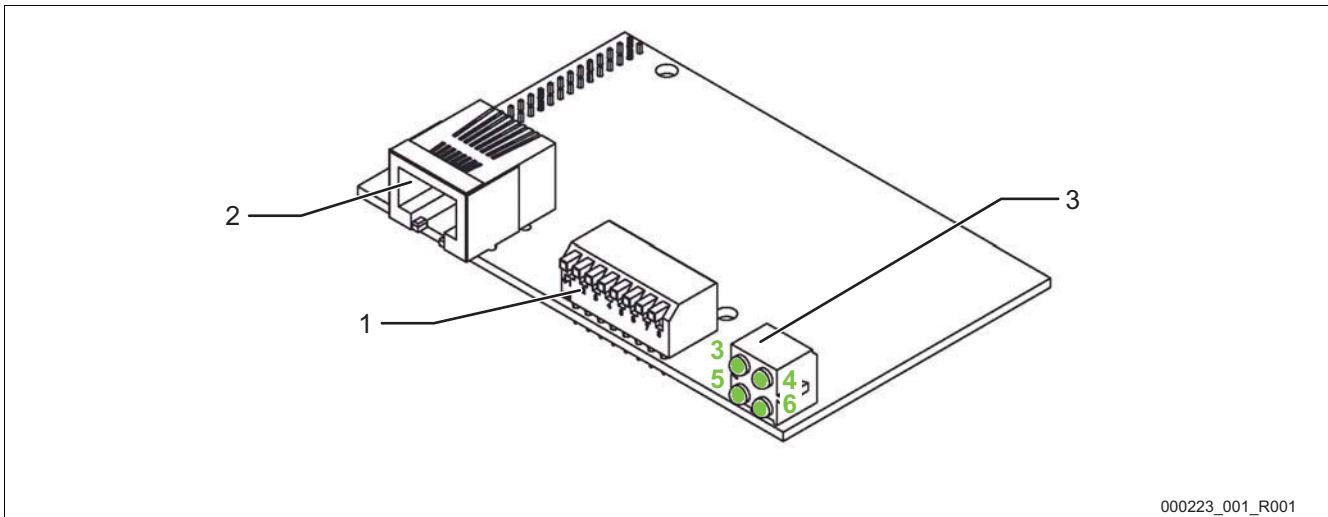

000223_001_R001

No.	Component
1	DIP switch
2	Connection for the RJ45 plug

No.	Component
3	Light emitting diodes

For the automatic configuration using the DHCP server, proceed as follows:

1. Set the DIP switch to the "OFF" position.
2. Ensure that the DHCP server has been activated.

Both conditions are default settings.



Note!

Check the conditions if other configuration methods have been previously used.

- If necessary, set the DIP switches to their original position.
- Activate the DHCP server in the web browser.

5.4 Setting the IP address with APR assignment

Use APR to set the IP address.

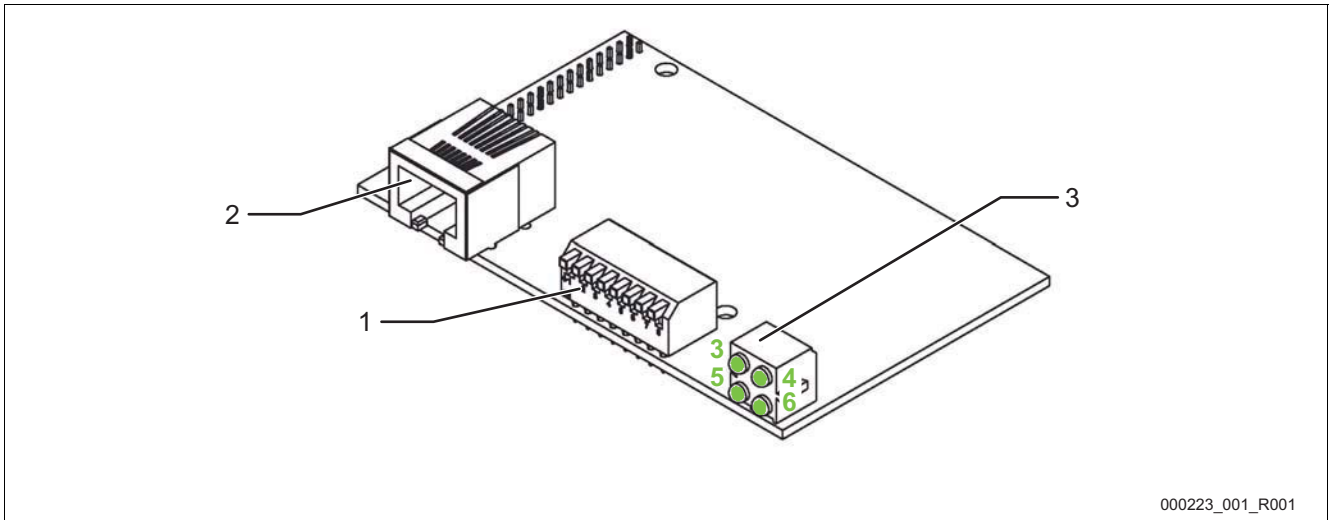

000223_001_R001

No.	Component
1	DIP switch
2	Connection for the RJ45 plug

No.	Component
3	Light emitting diodes

Proceed as follows to enable a setting using APR assignment:

1. Set all DIP switches on the Ethernet plug-in module to "OFF".
2. Ensure that the IP address of the PC matches the first three bytes of the IP address of the bus module.

Enter the following commands in the PC:

3. `arp-s <IP Address> <MAC Address>`
 - For example: `arp-s<192.168.1.124.> <00-30-11-02-13-37>`
4. `ping <IP Address>`
 - For example: `ping <192.168.1.124>`
5. `arp-d <IP Address>`
 - For example: `arp-d <192.168.1.124>`

The set IP address is permanently saved in the bus module. By default, the net mask is set to "255.255.255.0".

You can change the net mask and the gateway in the web browser.



Note!

- The IP address is the desired bus module IP address.
- the MAC address is shown on a label at the bus module.

5.5 Setting the IP address with the DIP switches

If the following restrictions apply to a local network, you can set the IP address using the DIP switches at the Ethernet plug-in module":

- IP address: 192.168.0.xxx
- Subnet mask: 255.255.255.0
- No gateway

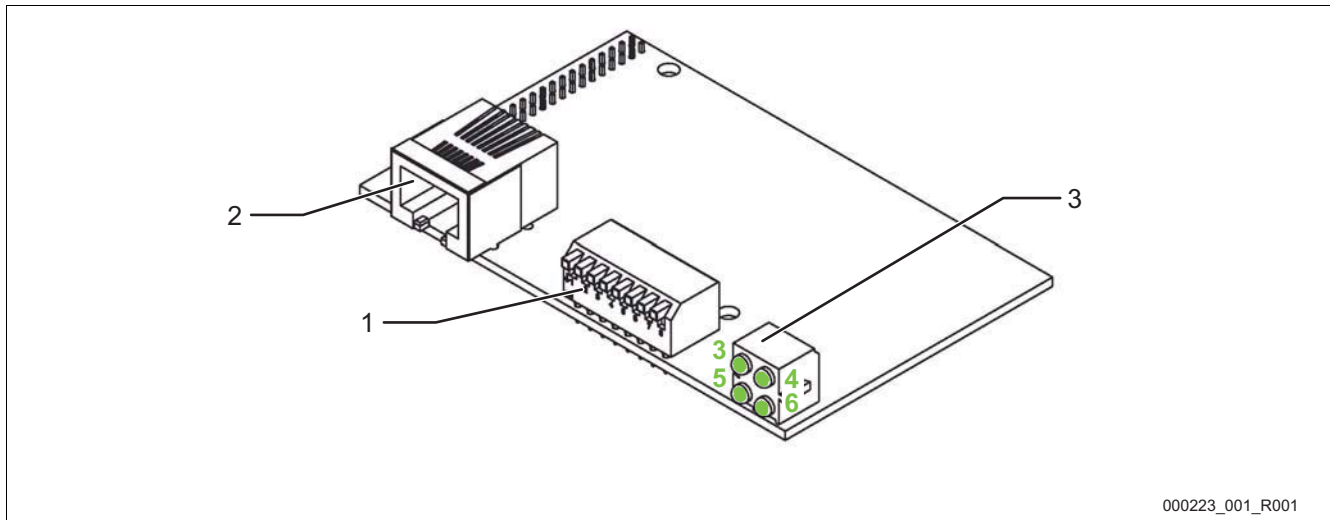

000223_001_R001

No.	Component
1	DIP switch
2	Connection for the RJ45 plug

No.	Component
3	Light emitting diodes

Set the IP address by switching the DIP switches on and off.

You set a number between 1 and 254 representing the last byte of the IP address (Host-ID).

The setting is a binary number where the "ON" position under a "1" corresponds to each binary number and the "8" DIP switch is the bit with the lowest value.

DIP switch								IP address
1	2	3	4	5	6	7	8	
0	0	0	0	0	0	0	0	Set with ARP assignment or DHCP server
0	0	0	0	0	0	0	1	192.168.0.1
0	0	0	0	0	0	1	0	192.168.0.2
1	1	1	1	1	1	1	0	192.168.0.254
1	1	1	1	1	1	1	1	Invalid

Only the settings for IP address and subnet mask mentioned are possible when you use this method to set the IP address. The bus module cannot be reached by any other subnets because the gateway is not supported.



Note!

- You cannot set the IP address with the DIP switches when all DIP switches are set to "OFF".
- In this case, you can set the IP address using ARP assignment or a DHCP server.

5.6 Network settings using a web browser

When you have set the IP address, you can use a web browser to access the integrated HTTP server of the bus module.

Proceed as follows:

1. Enter this address: `https://<IP Address>/nwconfig.html`.

- Use the defined IP address of the bus module for "<IP Address>".

The website displays a form containing the currently active network settings.

2. Confirm the following values in the website form:

- IP address
- Subnet mask
- Gateway
- DHCP active

3. Save the values in the website form.

4. Switch off and on the power supply of the bus module.

- The new settings are applied.

The setting process is completed.



Note!

If DHCP is activated, the DHCP server is used to assign the settings for IP address, subnet mask and gateway during activation.

6 Modbus/TCP

The bus module works as a Modbus/TCP slave. A Modbus/TCP server runs on Port 502 and provides the following functions for data retrieval:

Mode Function Code	Designation	Addressing
1	Read coils	Bit address
2	Read input discretes	Bit address
3	Read multiple registers	Word address
4	Read input registers	Word address

You can retrieve the following data:

Designation	Word address	Bit addresses
System pressure in 1/100 bar – Not for Servitec "Levelcontrol"	010h	
Filling level in % – Not for Servitec, optional Pressure filling pipe in 1/100 bar for Servitec	011h	
Digital outputs	012h	0120h Pump 2 ON 0121h Pump 1 ON 0122h Overflow valve 2 OPEN 0123h Overflow valve 1 OPEN 0124h Make-up valve OPEN 0125h Message: min. level – Not for "Control Basic" 0126h Message: Group fault 0127h Message: Make-up fault – Only for Gigamat on MK200 basis
Digital outputs	013h	0130h Feedback Pump 1 0131h Feedback Pump 2 0132h Insufficient water switch 0133h Water meter
Fault messages 1	014h	0140h Extension module defective – Optional 0141h EEPROM defective 0142h Undervoltage 0143h Below minimum pressure 0144h Insufficient water 1 0145h Pump 1 fault 0146h Compressor 1 fault 0147h Pump 2 fault – Not for "Control Basic" 0148h Compressor 2 fault – Not for "Control Basic" 0149h Pressure measurement fault 014Ah Level measurement fault 014Bh Pressure measurement spray tube fault – Only with Servitec 014Ch Stop mode for more than 4 hours 014Dh Insufficient water 2 – Only with Servitec

Designation	Word address	Bit addresses
Fault messages 2	015h	0150h Main circuit board fault – Not for "Control Basic" 0151h Digital input voltage fault – Not for "Control Basic" 0152h Analogue input voltage fault – Not for "Control Basic" 0153h Input voltage ball valve 1 fault 0154h Input voltage ball valve 2 fault 0155h "Pressure" jumper fault – Not for "Control Basic" 0156h "Level" jumper fault – Not for "Control Basic" 0157h Dry run – Only for "Control Basic" 0158h Insufficient water 3 – Only for "Control Basic" 0159h Insufficient water 4 – Only for "Control Basic"
Fault messages 3	016h	Not assigned
Warnings 1	017h	0170h Not used 0171h Maximum level exceeded 0172h Pump runtime exceeded 0173h Make-up time exceeded 0174h Make-up cycles exceeded 0175h Maximum pressure exceeded 0176h Make-up quantity exceeded 0077h Filling time exceeded – Only with Servitec 0178h Filling quantity exceeded – Only with Servitec 0179h Discharge period exceeded – Only with Servitec 017Ah Make-up valve leaking 017Bh Power failure 017Ch Null balancing defective 017Dh Parameter defective 017Eh Maximum make-up quantity exceeded 017Fh Maintenance requested

Designation	Word address	Bit addresses
Warnings 2	018h	0180h Replace battery – Not for "Control Basic" 0181h Softening, replace cartridge 0182h Check data logger – Not for "Control Basic" 0183h -- 0184h Stop mode for more than 4 hours – Only for "Control Basic"
Warnings 3	019h	0190h Expansion module, message digital input 1 0191h Expansion module, message digital input 2 0192h Expansion module, message digital input 3 0193h Expansion module, message digital input 4 0194h Expansion module, message digital input 5 0195h Expansion module, message digital input 6 0196h Expansion module, message digital Output 6
Operating hours Compressor/Pump 1	01Ah (H) 01Bh (L)	
Operating hours Compressor/Pump 2	01Ch (H) 01Dh (L)	
Water meter cumulative sum in litres	01Eh (H) 01Fh (L)	
Bus module status	020h	0200h No connection between bus module and controller 0201h MK200 design
Type	021h	1 Variomat 2 Variomat Giga 3 Reflexomat/C 4 Servitec 5 Fillcontrol Auto (only for "Control basic") 6 Servitec-25 – Only for "Control Basic" 7 Servitec-30 – Only for "Control Basic" 8 Fillcontrol Auto Compact – Only for "Control Basic" 9 Fillcontrol Plus – Only for "Control Basic"
Operating state	024h	0248h "MANUAL" operating mode 0249h "STOP" operating mode 024Ah "AUTO" operating mode

7 Operating state display on the web browser

An HTTP server is integrated in the bus module, providing you with access via web browser (if Java/JavaScript is installed).

Proceed as follows:

- Enter this address: `https://<IP Address>/nwconfig.html`.
 - Use the defined IP address of the bus module for "`<IP Address>`".

The website displays the current values of the Reflex controller which are automatically and continuously updated.

If the values are not displayed, you can open a static page without running Java.

Proceed as follows:

- Select "Status display without Java".
 - In this case, you must manually reload the website to display the new values.

8 Diagnosis



Danger – electric shock!

- Risk of serious injury or death due to electric shock. Some parts of the main board may still carry 230V voltage even with the device physically isolated from the 230 V power supply.
 - Before you remove the covers, completely isolate the device controller from the power supply.

The bus module features 6 LEDs indicating the operating state.

- LED1 and LED2 are located in the terminal space next to the terminal strip for the interfaces.
- LED3 to LED6 are located on the Ethernet plug-in module.

LED 1 and LED 2 in the terminal space

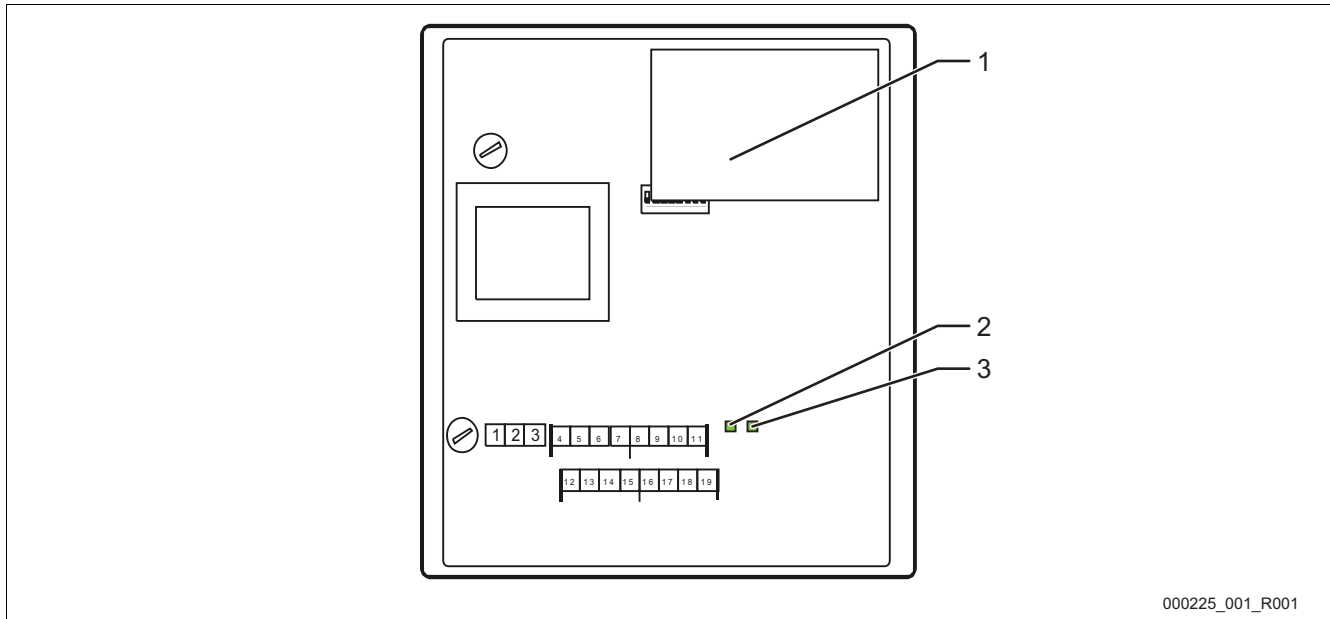

000225_001_R001

No.	Component
1	Ethernet plug-in module
2	LED 1

No.	Component
3	LED 2

LED 1 function:

Visual signal display of the controller connection

- Illuminated in normal mode.
 - The LED illuminates when a connection to the controller is established.
 - The LED flashes when there is no connection to the controller.

LED 2 function:

Visual signal display for the detection of the field bus module.

- Switched off in normal mode
 - The LED flashes when the Ethernet plug-in module has not been detected.

Alternate flashing of the LEDs 1 and 2 indicates that the bus module is in "firmware update" state:

- DIP switch 8 is set to "ON".
- A previous firmware update has been aborted.

LEDs 3 to 6 on the Ethernet plug-in module

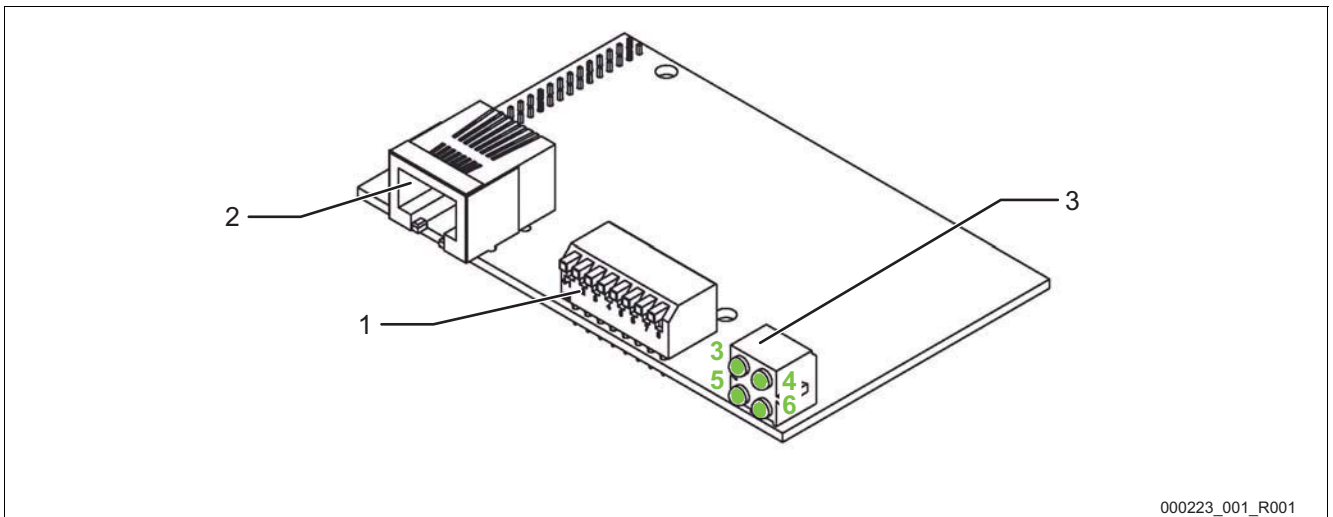

000223_001_R001

No.	Component
1	DIP switch
2	Ethernet connection

No.	Component
3	LEDs 3 to 6

LED 3 function:

Visual signal for the Ethernet link.

- The LED illuminates "green" when the bus module is connected to a "hub".
 - Independent of data transmission.

LED 4 function:

Visual signal for the bus module status.

- The LED illuminates "green".
 - The bus module works correctly.
- The LED flashes "green" or "red".
 - Fault in the bus module.
- The LED illuminates "red".
 - Fault in the bus module.

LED 5 function:

Visual signal for data transmission.

- The LED illuminates during data transmission.

LED 6 function:

Visual signal for the network status.

- The LED is off when no IP address is assigned.
- The LED flashes "green" when an IP address is assigned.
- The LED illuminates "red" when the assigned IP address is used by another device.
- The LED flashes "red" when "time-out" errors have occurred.

9 Replacing the fuses



Danger – electric shock!

- Risk of serious injury or death due to electric shock. Some parts of the main board may still carry 230V voltage even with the device physically isolated from the 230 V power supply.
 - Before you remove the covers, completely isolate the device controller from the power supply.

The fuses are installed in the terminal space of the bus module.

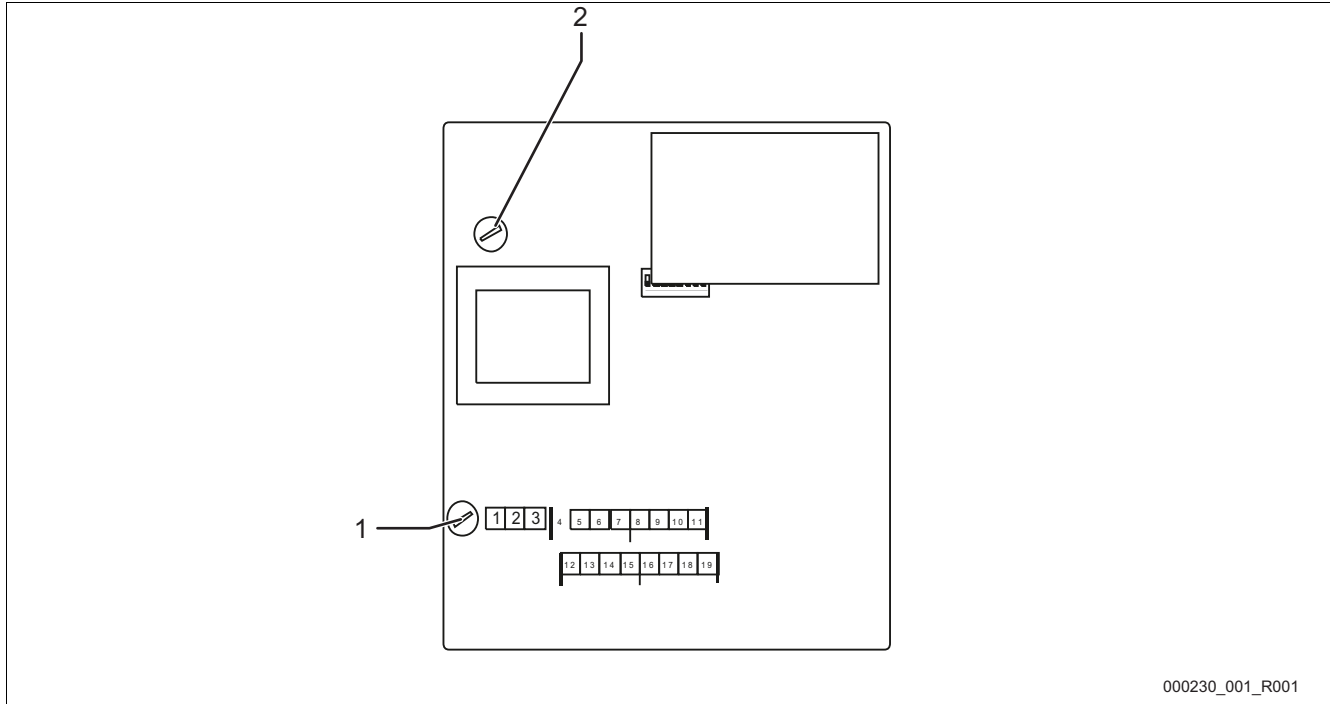

000230_001_R001

No.	Component
1	Feeble current fuse F1 <ul style="list-style-type: none"> • 250 V • 0.25 A time-lag

No.	Component
2	Feeble current fuse F2 <ul style="list-style-type: none"> • 250 V • 0.8 A time-lag

Proceed as follows:

1. Disconnect the bus module from the power supply.
 - Pull the power plug from the bus module.
2. Open the housing cover.
3. Replace the defective fuses.
4. Close the housing cover.
5. Reconnect the power supply for the bus module.

The fuse replacement is completed.

10 Firmware update



Danger – electric shock!

- Risk of serious injury or death due to electric shock. Some parts of the main board may still carry 230V voltage even with the device physically isolated from the 230 V power supply.
 - Before you remove the covers, completely isolate the device controller from the power supply.

A new firmware version is loaded to the bus module using the "COM1" serial interface.

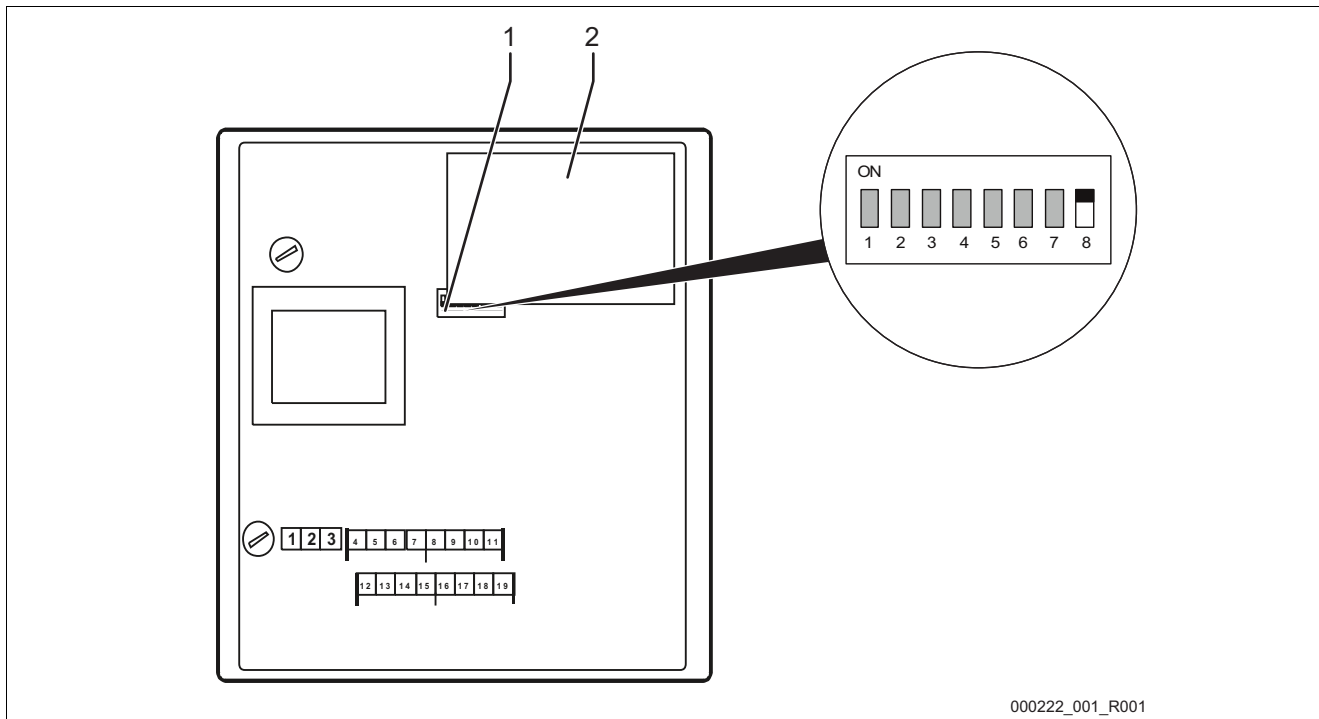

No.	Component
1	DIP switch

No.	Component
2	Ethernet plug-in module

To load the new firmware to the bus module, you need:

- A PC with an RS – 232 interface.
- A software for flash programming for the PC.
 - flash-xxx.exe
- The new firmware for the bus module (*.hex).

To connect the "COM1" interface, you have two options:

- COM 1 RS – 485.
 - Terminals 4 – 7
- COM 1 RS – 232
 - Terminals 12 – 15

Connect a "COM1" of the bus module with the RS-232 interface of the PC.

You need:

- RS – 232/RS – 485 converter.
 - For terminals 4 – 7
- Optional flash programming adapter.
 - For terminals 4 – 7
- Optional cable for the direct connection of the PCs RS – 232 interface with the bus module.
 - For terminals 12 – 15

To load the new firmware, proceed as follows:

1. Disconnect the bus module from the 230V power supply.
2. Open the housing cover.
3. Set the DIP switch "8" to "ON".
 - Do not change the settings of the other DIP switches "1 – 7".
4. Remove the connection between the Reflex controller and the bus module.
5. Connect the selected "COM1" interface with the PC.
6. Close the housing cover of the bus module.
7. Connect the bus module to the 230V power supply.
8. Start the "Flash programming" program on the PC.
9. In the program, click "Open".
10. Select the required HEX file in the program.
11. In the program, click "Burn".
 - If necessary, change the interface setting in the program.
12. Click "OK" to start the programming process.
13. Close the program when programming has completed.
 - The status bar displays the progress of programming.
14. Disconnect the 230V power supply of the bus module.
15. Open the housing cover of the bus module.
16. Disconnect the "COM 1" connection between PC and bus module.
17. Re-connect the Reflex controller and the bus module.
18. Set the DIP switch "8" to "OFF" for the bus module to enter the operating mode when switched on.
 - Do not change the settings of the other DIP switches "1 – 7".
19. Close the housing cover of the bus module.
20. Re-connect the 230V power supply of the bus module.
21. Check the functioning of the bus module.

Loading the new firmware to the bus module is completed.

11 DIP switch

DIP switch settings

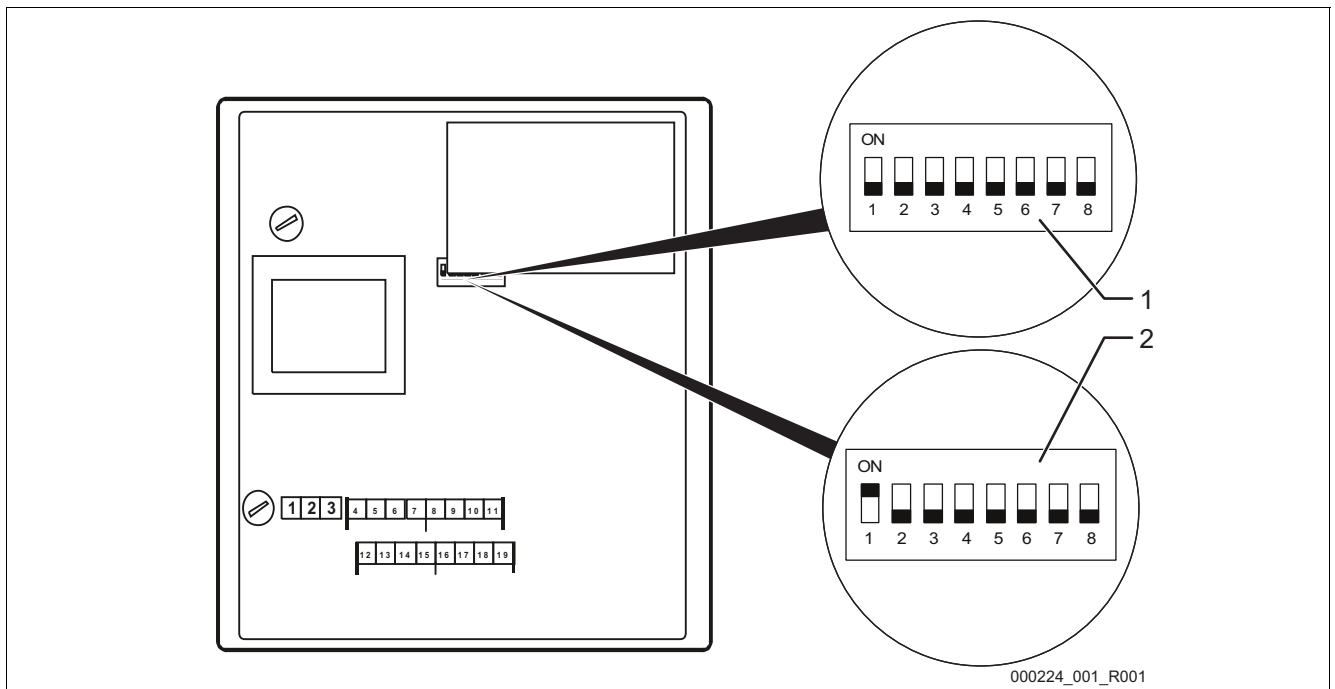

000224_001_R001

DIP switch:	Designation:
Magnifier 1 (optional)	Bus module for Ethernet <ul style="list-style-type: none"> Standard design
Magnifier 2 (optional)	Bus module for Ethernet <ul style="list-style-type: none"> MK200 design Module bus interface version Control Touch » RS485-s2
1	"COM1" interface function. <ul style="list-style-type: none"> "ON": Slave "OFF": Master
2	Selection of the used field bus plug-in module. <ul style="list-style-type: none"> "ON": RSI Profibus module (Profibus bus module) "OFF": HMS AnyBus module (other bus modules)
3	Reserved

DIP switch:	Designation:
4	Reserved
5	Reserved
6	FTP and Tenet activation. <ul style="list-style-type: none"> "ON": FTP and Telnet activated (for diagnostics) "OFF": normal mode
7	Switch to configuration mode. (currently only internally used by RSI) <ul style="list-style-type: none"> "ON": Configuration mode "OFF": normal mode
8	Switch to firmware update mode. <ul style="list-style-type: none"> "ON": Firmware update "OFF": normal mode



Note!

Change the DIP switches when a firmware update is executed on the bus module.



Note!

The bus module reimports the DIP switch settings when the power supply is switched on or off.

12 Annex

12.1 Reflex Customer Service

Central customer service

Switchboard: Telephone number: +49 (0)2382 7069 - 0

Customer Service extension: +49 (0)2382 7069 - 9505

Fax: +49 (0)2382 7069 - 523

E-mail: service@reflex.de

Technical hotline

For questions about our products

Telephone number: +49 (0)2382 7069-9546

Monday to Friday, 8:00 a.m. – 4:30 p.m.



Thinking solutions.

Reflex Winkelmann GmbH
Gersteinstraße 19
59227 Ahlen, Germany

Telephone: +49 (0)2382 7069-0
Fax: +49 (0)2382 7069-588
www.reflex.de