

Unical

MODULEX EXT.

ENBLOC MODULATING BOILER



A flexible “machine”

MODULEX EXT

MODULEX EXT	Thermal modules N. OFF	Output (condensing mode) (kW)	Modulation ratio	Production of condensate (kg/h)	Dimensions (L x P x H)
100	2	12 ÷ 100	1:8	15,3	764 x 770 x 1150
150	3	12 ÷ 150	1:12	23	764 x 770 x 1150
200	4	12 ÷ 200	1:16	30,6	1032 x 770 x 1150
250	5	12 ÷ 250	1:20	38,3	1032 x 770 x 1150
300	6	12 ÷ 300	1:24	45,9	1300 x 770 x 1150
350	7	12 ÷ 350	1:28	53,6	1300 x 770 x 1150
440	4	22 ÷ 432	1:19,6	73,4	1087 x 946 x 1448
550	5	22 ÷ 540	1:25	91,7	1355 x 946 x 1448
660	6	22 ÷ 648	1:29	110	1355 x 946 x 1448
770	7	22 ÷ 756	1:34	128,4	1623 x 946 x 1448
900	8	22 ÷ 864	1:39	146,7	1623 x 946 x 1448

Inimitable efficiency

- *deep modulation*
- *very high seasonal efficiency*
- *guarantee of operation*
- *compactness*
- *silence*
- *can be directly used in outdoor installation*
- *maximum accessibility to the components*

This is the DNA of MODULEX EXT.

A careful evolution of the previous one, of which it preserves the excellent prerogatives of success.

MODULEX EXT resolves any installation problem, both, hydraulic and electronic ones.

MODULEX EXT boasts, in absolute, the best ratio between: output/overall dimensions and weight.



*A “heating Motor” that goes beyond
the simple concept of boiler.*

- **Wide range formed by 12 gas condensing models**, with outputs from 100 to 900 kW.
- **Very high modulation ratio**, up to **1:40**, in order to supply always the “correct power”.
- Just one **technological boiler block**:
 - pre-assembled thermal elements in **aluminium, silicon and magnesium casting**
 - Unical patented, electronic management system, to instantly give the **maximum efficiency** at any modulated capacity: up to **109%** at the least modulated capacity.
- Integration of the electronic controller within the **disappearing panel board**.
- **Compact** ideal for difficult installations.
- **Light**, thanks to the reduced weight, it allows easy maneuverability in the introduction in the boiler house; *it can also be supplied in loosen parts and reassembled in the boiler house.*
- **Silent**: a “breath” also at its maximum capacities, thanks to its combustion characteristics and to the sophisticated technology of the new fans, gas valves and multi-gas burners.









The difference in 8 points



Unical
PATENT
15 claims

MODULEX EXT, the perfection of the technology applied to the heat production, was born from 10 years of experience, of success and updates.

Patented constructive technology

-  first generator with **modular sections complete of premix modulating burners**
-  castings of the **thermal elements in light alloy**
-  **cooling water ways** in serpentine shape
-  **original fin** to increase its exchange surface
-  **standardized flow and return manifolds without interceptions** between every section and hydraulically balanced
-  **burners, complete** of safety devices
-  **non return smoke valve**
-  command and control electronic system with **proportional regulation** of one/all the thermal elements

The details

MODULEX EXT



MODULATING PUMP



CROSS-SECTION OF THE PREMIX MULTI-BURNER



WORKING AND SAFETY TEMPERATURE SENSORS
IGNITION ELECTRODES & IONISATION PROBES



BUILT-IN NON RETURN
SMOKE VALVES



PREMIX BURNERS WORKING AT
CONSTANT CO₂



STANDARDIZED HYDRAULIC
MANIFOLDS



PRIMARY CIRCUITS WITH ADDITIONAL
SAFETY DEVICES KIT

5 year
guarantee

Thanks to its particular structure, synonymous of reliability in the time, the MODULEX EXT boiler body is covered by a 5 year guarantee.

Maximum saving and seasonal efficiency

High efficiency thanks to:

- certified efficiency up to **109%** at the minimum modulated capacity
- seasonal efficiency: **+ 30%** if compared with the conventional boilers
- inimitable modulation ratio: **UP TO 1:40**
- **modulating pump** directly managed by the boiler to assure the maximum condensation at all regimes

Total safety

- high reliability due to **MULTIBURNER** composition and to the low number of parts in movement
- **working and safety temperature sensors** on every casting section
- premixing within **the fan with non return built-in valve**
- **auxiliary electronic circuits**
- **emergency operation** in case the E8 controller is out of service

Flexibility of installation

- outdoor installation: protection degree **IPX5D**
- compact, light, of easy connection:
 - **reversible hydraulic and gas connections** (up to the mod. 350 kW)
 - **smoke evacuation: possible on 3 sides** (for all the models)

Low environmental impact

- **low polluting emissions** : <31 ppm Low NO_x (according to EN 15420)
- **low acoustic impact** <49 dBA
- **low chimney flue losses**
- **totally premix, radiation, modulating burners**, working at constant CO₂

Exclusive electronic technology

- **electronic management and thermal regulation** completely automatic and pre-programmed (patented)
- possible **cascade installation up to 8** boilers
- predisposition for **telemanagement and telecontrol**

Wide range of dedicated accessories:

- Primary ring with additional safeties Kit
- Plate heat exchanger with additional safeties Kit
- Acidic condensate neutralizers
- Regulation of additional zones

Pre-assembled thermal elements

MODULEX EXT is a thermal module fruit of the assembly of complete combustion units. Every unit is constituted by pre-assembled thermal elements, in **Al/Si/Mg**. Every element supplies, in continuous and progressive way, from 12 to 50 kW for the models up to 350 kW, and from 22 up to 108 kW for larger models.

More than 10 years experience assure:

- **resistance to the corrosion of the acidic condensate**
- **keeping of the very high thermal efficiency**

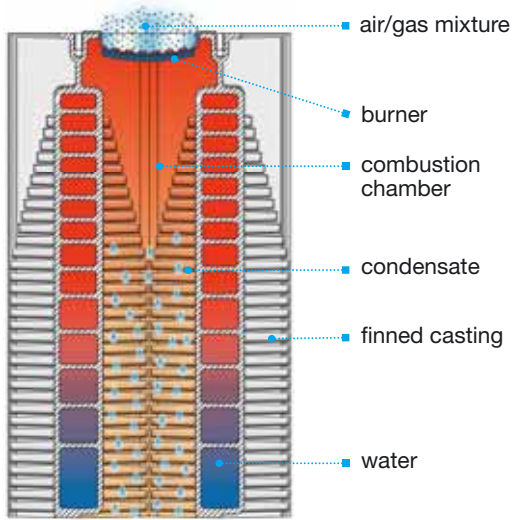

The basic element is formed by **two aluminium alloy castings** that, on the smoke side, have dense **finns**, with increasing height toward the smoke evacuation, placed in lower part of the casting, in order to increase its exchange surface (**Unical patent**).

Inside the castings there are the water channels that, always with more reduced section, zigzag cross the casting, granting an exceptional heat transfer from combustion gases to the water. Every thermal element is equipped with:

- *premix modulating radiation burner*
- *two stage modulating gas valve*
- *electronic ignition and ionization*
- *NTC working temperature sensor*
- *safety thermostats*
- *flame sight glass.*

The smoke and acidic condensate of the thermal elements are collected in a stainless steel tray.

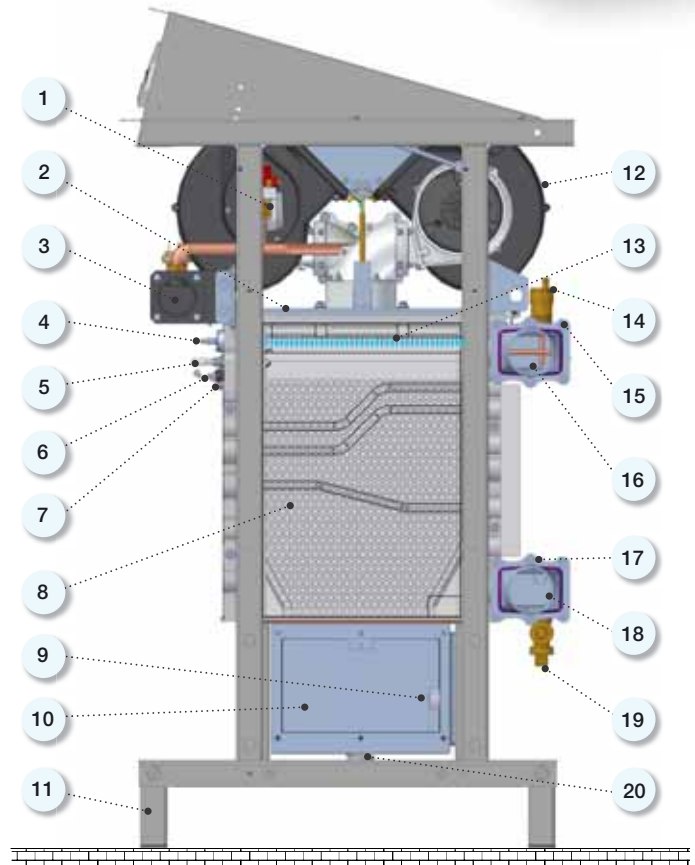

Key:

- | | |
|--|---|
| 1 - Gas valve | 11 - Frame |
| 2 - Burner cover | 12 - Fan |
| 3 - Gas pipe | 13 - Burner |
| 4 - Ignition electrode | 14 - Automatic air vent |
| 5 - Ionization probe | 15 - Global NTC flow temperature sensor |
| 6 - Local NTC temperature sensor | 16 - Central Heating flow sensor |
| 7 - Limit thermostat | 17 - Global NTC return temperature sensor |
| 8 - Aluminium alloy heat exchanger | 18 - Central Heating return |
| 9 - Condensate level sensor | 19 - Boiler drain tap |
| 10 - Condensate & smoke tray- chimney connection | 20 - Condensate evacuation |

Radiation combustion

Totally premix

Main protagonist for a perfect combustion and therefore the maximum efficiency, is the **modulating fan** (1000-6000 rpm) of which every unity is equipped.

The number of rpm of the fan, together with the opening of the valve gas and the flame control, is directly programmed and controlled by the electronics of every burner (BMM Burner Modular Module) and, at their turn, they are managed by the E8 controller.

The output modulation depends on the rotation speed of the fan and is based on the difference between *the C.H. required temperature, the maximum planned one and that indeed measured.*

The opening of the valve gas is produced by the “*Venturi effect*” in the Cochlea of the fan and the mixture air and gas happens to its inside before being introduced in the combustion chamber (premix).

This perfect “mixing” combines the air and gas in parts always proportionate to produce, through the multi-gas burner, the “*radiation combustion*”.

This system, characterized by the issue of electromagnetic radiations, is the most efficient for the transmission of the thermal energy.

The wide surface, on which the combustion happens, guarantees:

- *low combustion temperature*
- *reduced turbulence*

with the following **advantages**:

- long lasting of the burner thanks to the low thermal and mechanical solicitations and to the physical inalterability of its mesh in FeCr Alloy fibre that, thanks to its chemical-physical structure, constitutes an ideal radiation means
- high combustion silentness thanks to the low pressure and to the anti-resonance structure of the fan, capable of developing a soft flame
- simple maintenance thanks to the use of few components and easy accessibility
- larger quantity of transmitted energy in comparison to a traditional burner with the same flame temperature
- absolute working safety for the absence of turbulences
- very small production of pollutants due to the complete oxidation of the gas molecules;
 - excellent combustion efficiency: maximum $\text{CO}_2 = 9,3\%$
 - efficiency optimization thanks to the low smoke temperature and the limited “air excess”
 - very low pollutant emissions: $\text{NO}_x < 53,8$ mg/kWh (pondered value according to EN 15420).

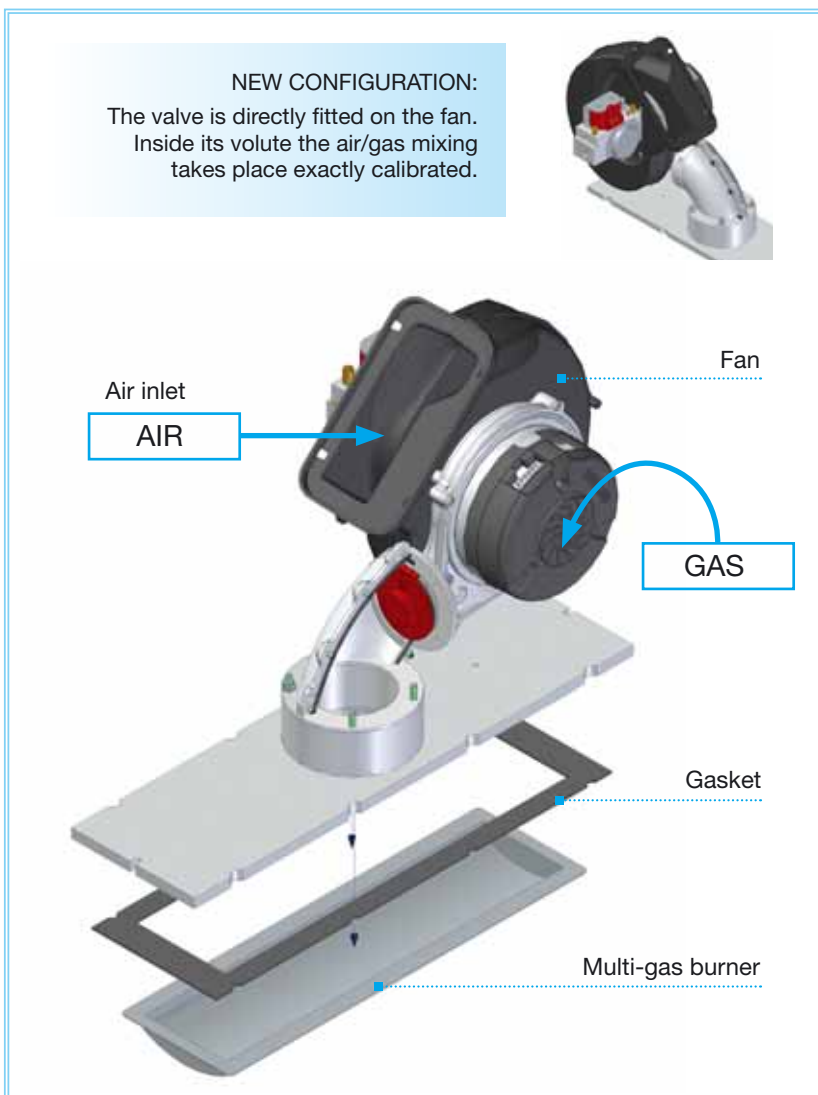

Instant answer energy

MODULEX EXT, of revolutionary constructive conception, that, more than 10 years ago, broke the classical schemes of the boilers to the point not to find applicable reference standards, anticipates characteristics today become a must.

Setting possibility according to the thermal needs of the C.H. system

This function allows to drastically reduce the number of switching ON and OFF of the boiler. (Possible customization of the requested output).

Advantages:

- Higher efficiency and lower flue losses when burner is OFF.
- Longer lasting of the parts in movement and of the ignition systems.

Very low water content and high modulation speed with maximum output ratio up to 1:40

On average a boiler operates for satisfying the actual 50% of the thermal needs of the C.H. installation and descend also below 30%. MODULEX EXT adjusts in real time its output to these necessities, because it is not influenced by the thermal inertia, thanks to its low water content and, being equipped with modulating pump, it further reduces the electric consumptions.

Class A, variable speed, electronic pumps, for the maximum condensate production

This function exalts the production of condensate and therefore the fast economic recovery of the investment. All this in order to offer the user the possibility to save with the maximum comfort both, for C.H. and D.H.W. production, with a lower noise level than the traditional boilers.

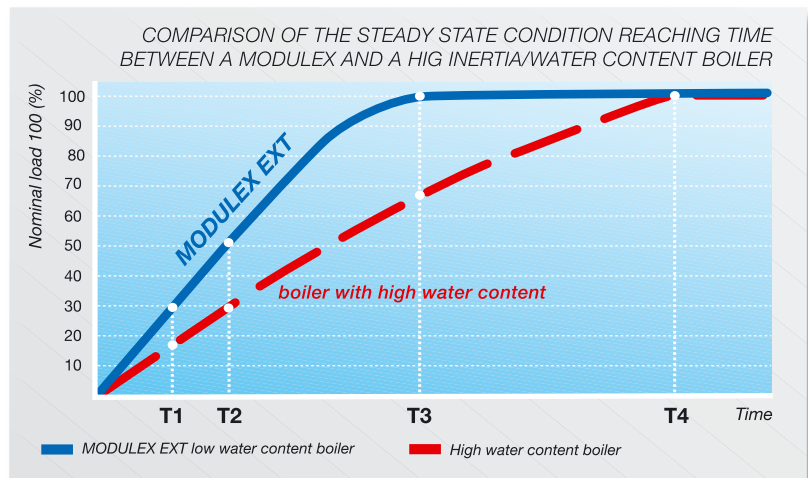
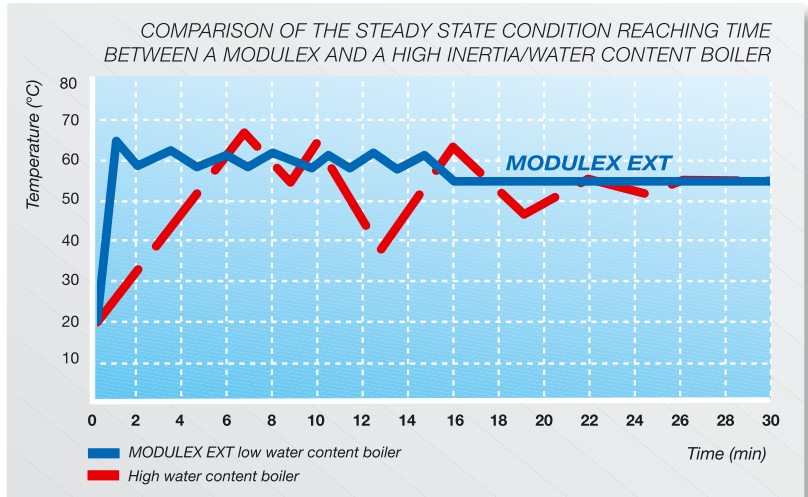

After the time "T1" from the starting, MODULEX EXT succeeds in satisfying the 30% of the load unlike a traditional boiler that, in the same time, is just at 15%.
After the time "T2" MODULEX EXT is at 50% of the load, while the traditional one is at 30%.
After the time "T3" MODULEX EXT is at 100% of the load and the traditional one is only at 70%.
This is an example of speed of a genial boiler!

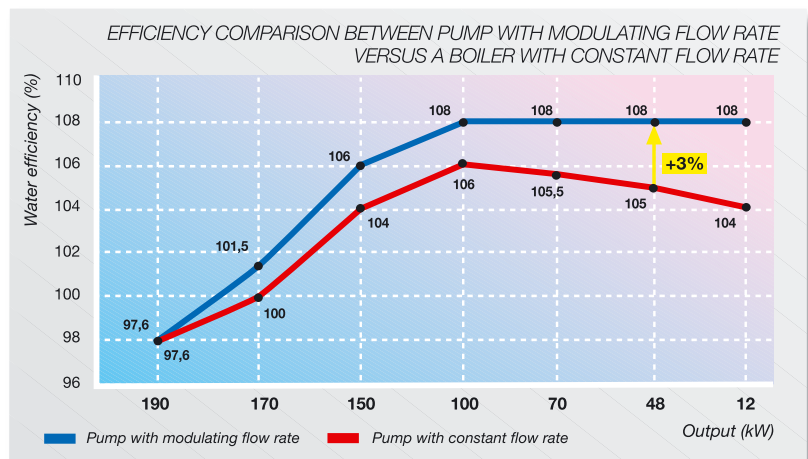

Disappearing panel board

Surprising the access to the panel board!

A perfect pneumatic system with gas dampers lifts the impermeable cover of MODULEX EXT. The safety block prevents tampering.



E8 Thermo-controller

BCM Boiler Cascade Manager

This way appear:

- **E8** the Thermo-controller
 - **BCM** Boiler Cascade Manager
- that represent a decisive qualitative jump in the management of the boiler according to the applied loads.

E8 is supplied complete with:

- external temperature sensor
- flow temperature sensor for mixed zone (zone 1)
- boiler temperature sensor
- D.H.W. storage tank temperature sensor

Besides to become the dialogue window with the boiler, thanks to its peculiarities, E8 allows the complete management of the C.H. system, exploiting the maximum attainable condensation and output modulation.

Modulation in cascade

The applicable systems of communication: **eBUS, Mod-bus and canBUS** allow the maximum elasticity in the cascade management, leaving **free choice** to the consumer for the **last interface of management**.

CASCADE MANAGED BY E8

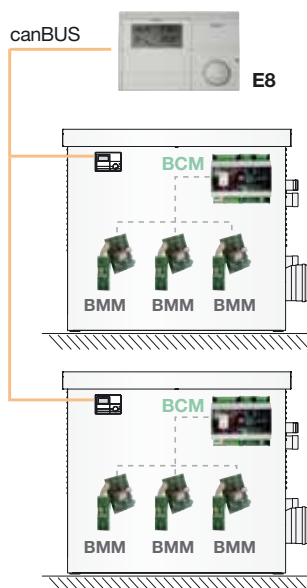

CASCADE MANAGED BY PLC

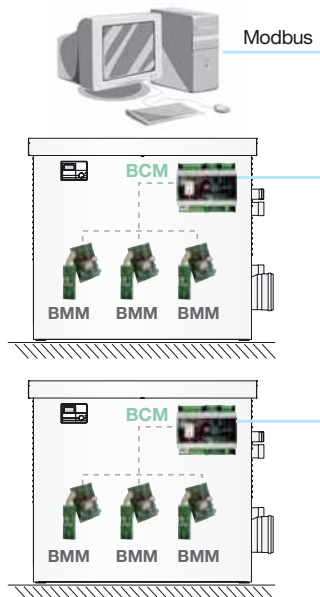

CASCADE MANAGED THROUGH BCM

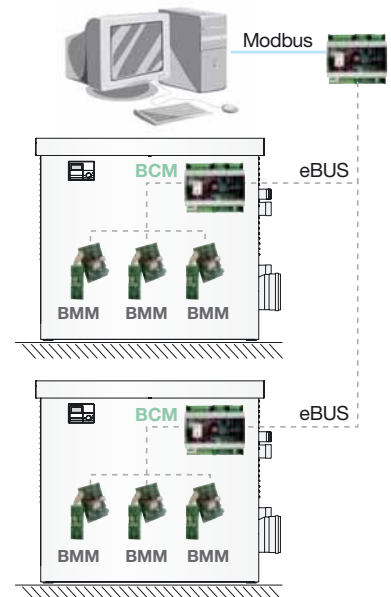

A clever brain

E8, the thermo-controller

- **Cascade of 2 up to 8 MODULEX EXT**
With simple connection.
- **KIT OF ZONE EXPANSION E8**
To control 2 direct/mixed zones and a D.H.W. storage tank up to a maximum of 7 modules that can be connected with a two wire cable.
- **Remote management and remote control**
Through dedicated software and accessories, with electronic board CO.CO.PC and GSM connection.
- **Communication**
With the central automation systems (PLC).

For additional information, please contact our pre-sale department.



System optimization



Boiler heating Optimization

The heating controller, on the basis of the timer/heating programme set by the user, once the system's characteristics have been evaluated, will activate the function for automatically bringing forward the heating ignition time so as to ensure that the set temperature is reached at the time requested by the user.



Fast set temperature

This is obtained by calculating the optimum ignition start-up time. This calculation can be carried out taking into consideration the outdoor temperature or the room temperature.



Overheating protection

The boiler's safety temperature is controlled via the pump's overrun time in order to get rid of any thermal inertia.



Self-adaption

Through the elaboration of data transmitted by the room sensor, this function adjusts the boiler's output to the building's characteristics, ensuring a constant monitoring of the indoor temperature on the basis of the variation of the outdoor temperature, keeping in consideration the building's thermal inertia and the contribution of "free" heat (solar radiation, internal heat sources etc).



Slope offset (heating slope distance)

The boiler temperature that is required for a mixed circuit is calculated by adding to the calculated temperature setting for the heating circuit temperature the heating slope distance. The heating slope distance compensates for sensor tolerances and heat loss up to the mixer.



Valve opening time

Based on the characteristics of the servomotor.



Number of burner ignitions

It stabilizes the number of ignitions of each burner.



Burner run hours

It stabilizes the run hours of each burner.



Frost protection mode

The frost protection operation mode prevents the CH system from freezing by automatically switching heating operation on. In the frost protection mode, the room temperature for all the heating circuits is set to 5°C and the storage tank sensor frost protection is activated when the temperature drops below 10°C.



Swimming pool heating function

DHW control



Domestic hot water production

There are many programmes which control the domestic hot water production. You can choose from the maximum of comfort to the maximum fuel saving. In order to permit the storage cylinder to supply hot water rapidly, the heating controller brings the boiler's temperature to the maximum set value.



Antilegion

Every 20th heating start-up or once a week on Saturday at 01:00 hrs, the storage tank is heated up to 60°C. This function will eliminate any eventual pathogens which have formed in the DHW.



DHW optimization (loading pump)

The DHW loading pump is switched on only if the boiler temperature exceeds by 5°C the storage tank temperature. It is deactivated when the boiler temperature drops below the storage tank temperature or if the storage tank temperature is higher than the nominal temperature.

Setting



Programme setting

The heating programmes can be set daily or weekly, with more than one On-Off firing times or temperature reductions during the arch of the day.



Multiple zone control

With the same heating control device you can control 2 independent circuits with different characteristics, though having ensured all the described functions, including the deep sliding temperature function.



Management of up to 15 mixed circuits

controlled by the outdoor sensor



0-10 volt signal

the great flexibility of the E8 also permits the MODULEX EXT set point to be controlled by an external control signal. This will enable, having at disposal an even more complex system, to exploit all the heating control's functions..

Energy sources control



Integration with renewable energy sources

As for example: solar systems and/or solid fuel fired boilers.

Boiler Cascade Manager

BCM

BCM, powerful electronic module, created by Unical for:

- Managing the inside cascade of the boiler thermal elements
- Supplying double certainty of operation (emergency operation in case of breakdown to the thermo-controller E8, with activation of the heat request at constant setpoint with maximum capacity of 50%)
- Managing the modulating pump of the primary rings (Analogical outlet 0-10 V) with significant efficiency increase at part loads

- Allowing the integration in the boiler house automation systems, realized with industrial PC /lonWorks/Modbus for Building Automation
- Checking the heat demand: temperature setpoint and modulation level
- Monitoring the state of working temperatures
- Planning the parameters
- Managing and resetting the alarms
- Remoting alarm signals through relay.



Cascade installations

With the cascade installation, the boiler output range can be widened well **over 900 kW**, so multiplying output and modulation in order to satisfy any design demand. The space saving (particularly it can be installed up to 40 cm from the boiler house walls) and its structure, strongly

addressed to a service model highly rational and of fast intervention, will make convenient its installation where rapid savings and elevated technical results are wanted, for example in the replacement of the obsolete boiler

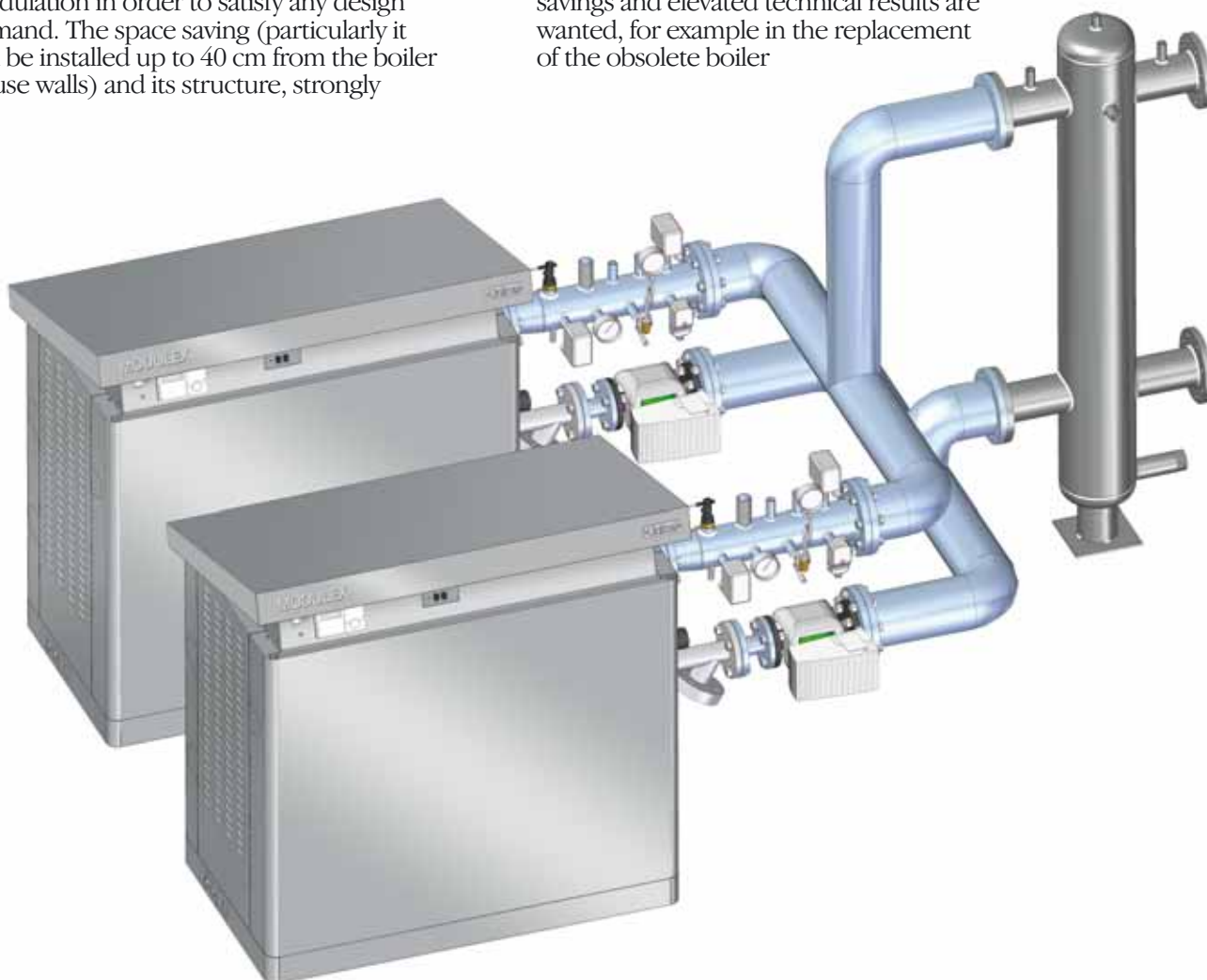

The top logic

Output flexibility and efficiency

MODULEX EXT has a certified efficiency that, for the models superior to 350 kW, when working in condensation, progressively increases up to **109%** when the output is reduced.

The particularity of the thermo-controller E8 is to keep ON the **greater number of elements** as possible, working at the **smallest possible output** (as shown in the examples beside).

Exploiting this peculiarity, the system will always work in the conditions of maximum possible efficiency, independently from the supplied output.

Always with the same principle when the C.H. needs go reducing, also the capacity of every module will be regulated and reduced consequently in proportional measure. Being the least power of every module 12 kW (models up to 350 kW), if the requested output is lower than the addition of the least powers of the single modules (n° modules \times 12 kW), will be maintained operational only the elements necessary to the attainment of the requested output, working at the maximum efficiency, and disabled the others.

Besides, to assure an equal daily rotation of the modules, every 24 hours the ignition of the modules will be alternate so that every one operates for the same number of hours.

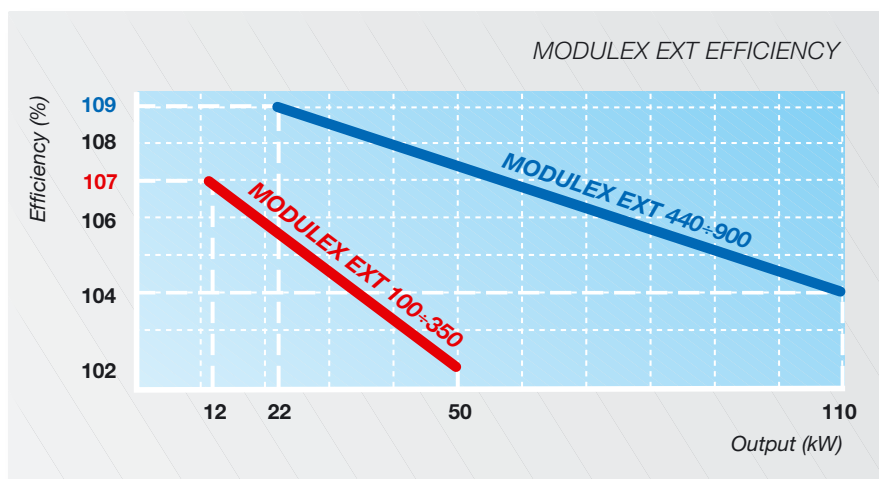

Output sharing of MODULEX EXT of 4 modules of 50 kW

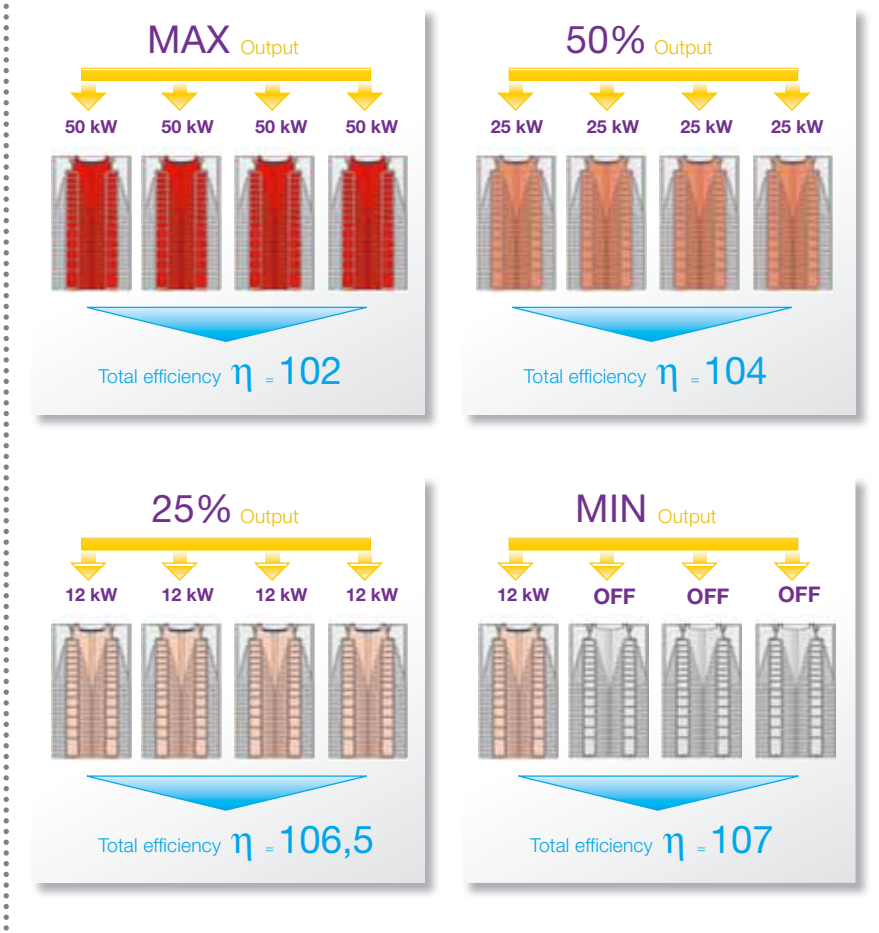

The right solution...

The integrated design of the building-installations system: from the boiler to the Unical integrated system

With the collaboration of the designers of heating systems, more sensitive to the actual energetic problems, Unical, in the time, has turned the MODULEX EXT in the fulcrum of a real dedicated system, "PLUG & PLAY" to realize installations that optimize:

- *Comfort and low energetic consumptions*
- *Small size installations (downsizing)*
- *Control of the investment cost (cost of the life cycle)*
- *Integration of the renewable sources*
- *Execution speed*
- *Reduction of the maintenance costs*

The professionals, therefore, can count on a series of coordinated elements, entirely studied and produced by Unical:

- **Primary rings** for installation interface plant with mixing header
- **Primary rings with plate heat exchanger**
- **Zone satellites** that, connected to the central boiler, allow the end user to have in his house the convenience of an autonomous boiler, without flame, assuring maximum individual comfort and minimum consumptions, always under control.



Floor heating
The low temperature operation is translated in less necessary heat with consequent saving. With the range **STRATINOX**, the technician has all the necessary to realize a heating system that respects the comfort of the consumer, inclusive of the guarantee of Unical experience.



...for a perfect installation

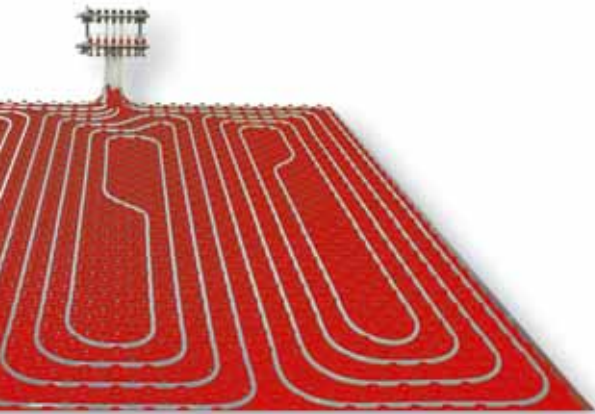

MAX MULTIPLEX

System of pipeline in multi-layer PEX-Al-PEX for heating /conditioning and sanitary use, with thermal insulation, complete of press fittings and all the accessories for an easy installation.



SATAL

Apartment modules for the autonomous management of the centralized heating, with room temperature regulation and devices for energy and sanitary water countering for the sharing of the expenses.



With the thermal solar panels the whole heat of the sun is captured: **TITANIUM, TITANIUM O, TITANIUM XL e BLUETECH 2500** are the complete offer of Unical to get free heat.

An efficient solar system needs reliable components, such as **solar circulation groups and controllers**. Unical puts a **complete range of accessories** at the service of the technician.



The range of **BISER** storage tanks with high efficiency coil allow an elevated heat exchange and optimize the integration through the thermal solar panels.

The Unical pre-sale service will supply consultation to the planning to best exploit the exclusive characteristics of **MODULEX EXT**.

Primary rings with mixing header

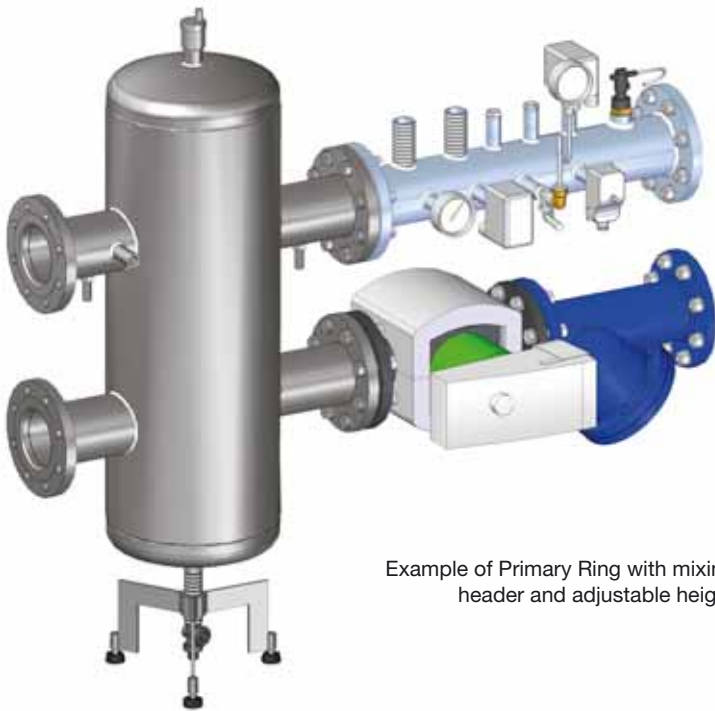

Example of Primary Ring with mixing header and adjustable height

Class A modulating pump

Balance between supplied output and water flow rate. Extraordinary strength's point for all the MODULEX EXT is the **modulating pump**, directly controlled by the boiler.

For the first time, in a low water content multi-section boiler, a perfect equilibrium is created between the supplied output and the water flow rate, practically under all the working conditions.

Thanks to the advanced electronic panel board, the BCM card elaborates, in continuous way, the data related to the Δt between flow and return and the supplied output.

The result of this comparison will bring to:

- **Increase of the pump flow rate** if the thermal jump increases too much
- **Reduction of the pump flow rate** if the thermal jump reduces too much.

It follows that the exploitation of the condensation is the best, because MODULEX EXT always operates with the return temperature as low as possible.



Primary rings pre-assembled and with jacket

MODULEX EXT is a low water content boiler and therefore a low thermal inertia boiler:

- *high speed of output supply*
- *immediate answer to the load variations*
- *minimal heat losses.*

The great variations of flow rate and temperature that follow are, therefore, conveniently balanced by the so-called hydraulic separator, before reaching these ultramodern "heating engines".

Unical introduces **the new range of 5 primary rings with ultra-compact hydraulic separators.**

Advantages:

- *Complete system, developed and tested in our laboratories*
- *Rapidity of putting into service*
- *Class A modulating pump*
- *OGNITEMPO EXT, a special casing for coverage of the primary rings in outdoor installations (class IPX5D).*

Mixing headers

Designed and manufactured in Unical, they follow rigorous sizing criteria, in terms of:

- **Ideal hydraulic balance** (interference almost nothing between primary and secondary ring)
- **Crossing speed near to zero** (minimal temperature increase on the boiler return to safeguard the condensing and the decanting effect)

developing three fundamental functions:

1. To make independent the connected circuits
2. "Deslimers", allowing the collection of the mud of the circuits
3. "Deaerator", to allow the automatic evacuation of the air.

Installation components



PRIMARY RING composition

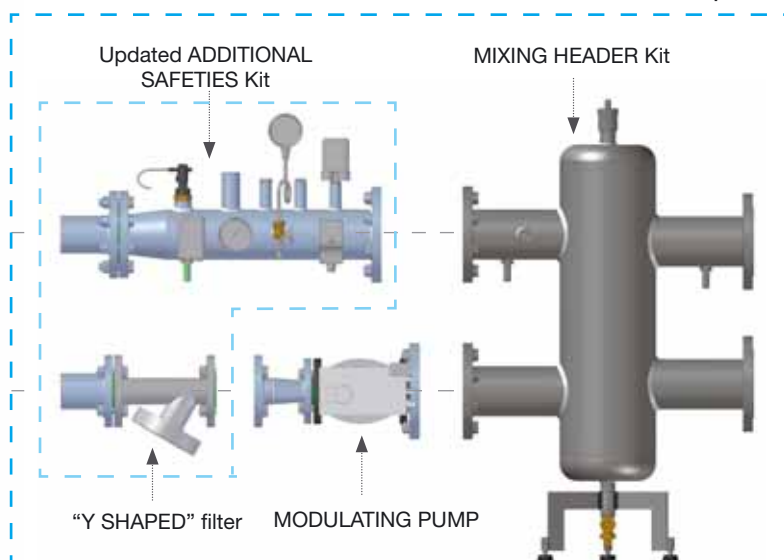

PRIMARY RINGS MIXING HEADER combination with MODULEX EXT	Maximum controlled output (kW)	Code
100 ÷ 150	150	00361944
200 ÷ 250	250	00361945
300 ÷ 350	350	00361946
400 ÷ 770	756	00361994
900*	864	00361995

* For higher capacities further sizings are available on demand. Some additional safety devices are not supplied because their sizing depends on the installation type.

MIXING HEADER KIT combination with MODULEX EXT	Maximum controlled output (kW)	Code
100 ÷ 350	350	00361976
440 ÷ 900	864	00361997
> 900 ÷ 2700*	2700	00361501

* For information contact our pre-sale office.

ADDITION SAFETY DEVICES KIT combination with MODULEX EXT	Maximum controlled output (kW)	Code
100 ÷ 350	350	00361980
440 ÷ 770	756	00361998
900	864	00361999

Coverage OGNITEMPO EXT for MIXING HEADER combination with MODULEX EXT	Code
100 ÷ 350	00362008
440 ÷ 900	00362069

UPDATED ADDITIONAL SAFETIES ASSEMBLY

Following the evolution of the Standards, the pipe that lodges the safety devices foreseen by the rules in force, has been updated to foresee possible new devices.

CONTROL DEVICES

- 1 - Pressure gauge with shock absorber and a cock for manometer: it shows the actual pressure in the boiler, it must have the dial graduated in "bar", the bottom of the dial correlated to the maximum working pressure and be equipped with a three way cock for the connection of a master pressure gauge.
- 2 - Thermometer: it shows the real temperature of the water contained in the boiler; its dial must be graduated in centigrades, with bottom of the dial not superior to 120°C.
- 3 - Bulb holder: for master thermometer.
- 4 - Stub pipes R 1 1/4": for the insertion safety valves.
- 5 - Y shaped filter.
- 6 - Modulating pump.
- 7 - Mixing header.

Not furnished because to be sized according to the characteristics of the installation:

- Certified expansion vessel: it allows to absorb the volume increase of the C.H. system water following the temperature increase; the design pressure has not to be higher than the setting pressure of the safety valve.
- Purging valve and drain cock.

PROTECTION DEVICES

- 8 - Safety thermostat: it has the function to stop the boiler in case the limit thermostats, fitted in the boiler sections, are out of order. Its setting must NOT be changeable and must be smaller than 100°C.
- 9 - Minimum water pressure switch: it has the function to stop the boiler in case the minimal working pressure is below (0,5 - 1.7 bar). It has to be of manual reset type.
- 10 - Additional stub pipe R 1".
- 11 - Safety pressure switch: it has the function to stop the boiler in case of attainment of the maximum working pressure (5 bar). Adjustable 1 to 6 bar.

Primary rings with plate heat exchanger

For the completion of the installation interfaces, we propose a **new range of 6 primary rings with plate heat exchanger**.

Advantages:

- *physical separation: hydraulic circulation is not present among the 2 circuits, the primary of boiler and secondary of the installation - possible different working pressure between primary and secondary circuit (for example: closed expansion vessel for the boiler and open expansion vessel for the C.H. circuit)*
- *boiler installation on old, obsolete C.H. circuits with potential risks of sludge or water leaks, with consequent frequent water reinstatements*
- *external installation with primary circuit protected against freezing and secondary circuit with not treated water*
- *variation of exchange parameters in case of C.H. system modifications, by adding or removing plates*

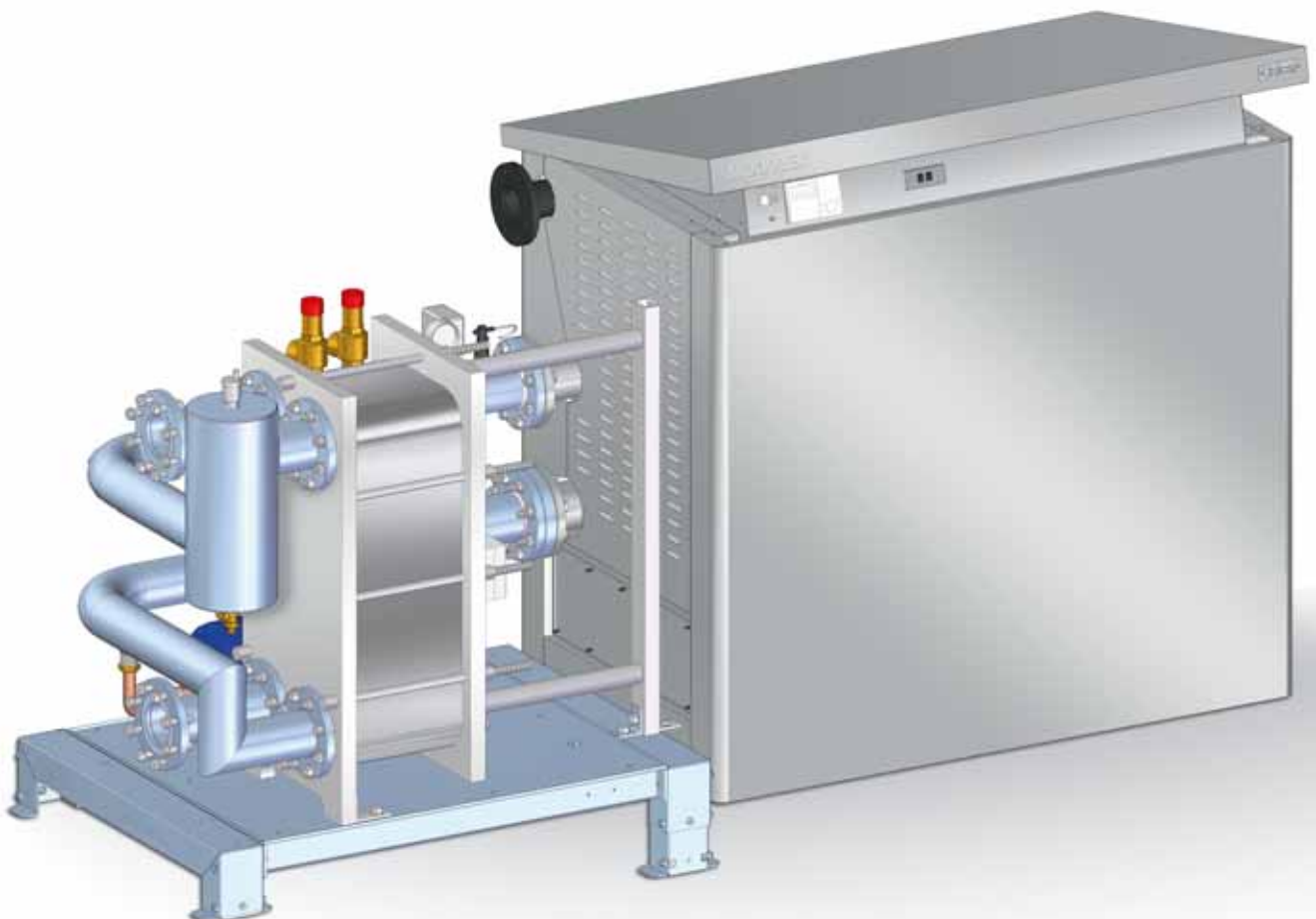
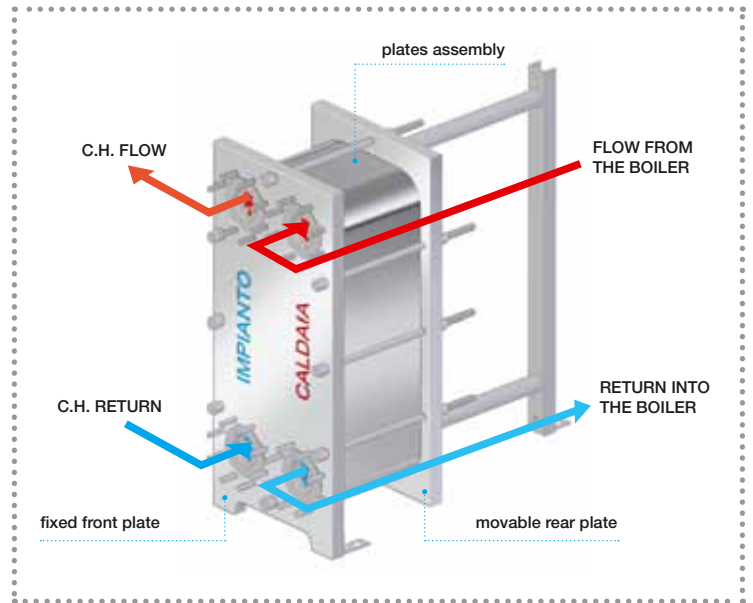

PRIMARY RINGS PLATE HEAT EXCHANGER	Code	Maximum controlled output	PRIMARY working temperatures	SECONDARY working temperatures	PRIMARY FLOW RATE m ³ F/R 80°/65°	SECONDARY FLOW RATE m ³ F/R 80°/65°
<i>combination with MODULEX EXT</i>		(kW)	(°C)	(°C)		
100	00361949	200	80 ÷ 65	70 ÷ 60	5,75	8,62
150	00361949	200	80 ÷ 65	70 ÷ 60	8,62	12,93
200	00361949	200	80 ÷ 65	70 ÷ 60	11,49	17,24
250	00361951	350	80 ÷ 65	70 ÷ 60	14,37	21,55
300	00361951	350	80 ÷ 65	70 ÷ 60	17,24	25,86
350	00361951	350	80 ÷ 65	70 ÷ 60	20,11	30,17
440	00362167	550	80 ÷ 65	70 ÷ 60	25,29	37,93
550	00362167	550	80 ÷ 65	70 ÷ 60	31,61	47,41
660	00362168	660	80 ÷ 65	70 ÷ 60	37,93	56,90
770	00362169	770	80 ÷ 65	70 ÷ 60	44,25	66,38
900	00362172	900	80 ÷ 65	70 ÷ 60	51,72	77,59

Thanks to the modulating pump all the advantages already seen for the models with mixing header are maintained:

- **Δt nearly constant** for all the outputs
- **Efficacy in the condensating power**
- **Energy recovery.**

The supply, in parts to be assembled on site, foresees:

- stainless steel AISI 316 L plate heat exchanger, with sealing gaskets in NBR, suitable for temperatures -15°C to 135 °C
- additional safety devices kit
- modulating pump
- mechanical filtration system for the sludge
- accessories, connections and basement
- *optional:*
OGNITEMPO EXT for coverage of primary rings, suitable for external installations (class IPX5D).



OGNITEMPO EXT for coverage of PLATE HEAT EXCHANGER	Code
<i>combination with MODULEX EXT</i>	
100 ÷ 350	00362113
440 ÷ 900	00362120

Optional accessories

To complete the installation are besides available (optional) some practical supports to sustain the weight of the smoke channel, avoiding therefore that it charges directly on the smoke evacuation assembly of the boiler.

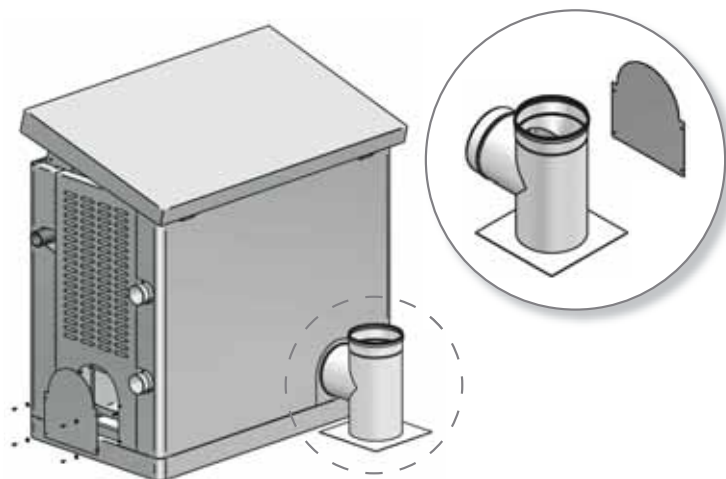

REAR SMOKES EVACUATION KIT FOR MODULEX EXT 100 TO 350
Cod. 00362076

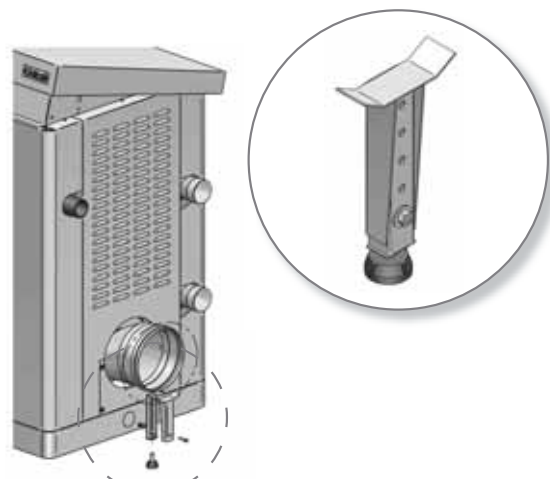

FLUE TERMINAL SUPPORT KIT
Cod. 00362075

Neutralizers optional Kit

The condensate, produced during the combustion process, reacts with the NO_x forming acidic molecules ($\text{PH} = 4,5$). It could be demanded that the condensate is neutralized before its immersion in the sewerage. In the respect of the ecosystem, Unical proposes the neutralizers of condensate NH.

KIT NH 300 - for boilers up to 300 kW (cod. 00262827): the neutralization happens according to the principle of the passage of the acidic condensate through the granular neutralization material. The passage happens upward from the lower part.

Kit NH 1500-P - for boilers up to 1500 kW (cod. 00262829): in the system NH 1500-P the condensate flows through a patented run in a zone filled with granular neutralizing material, in which an integrated filtering layer is also found. At the exit from such a zone the neutralized condensate reaches a level controlled pump, operating also as lifting system, that push it toward the evacuation duct. This system is able to treat up to 550 l/h of condensate, for boilers up to 1500 kW.

		NH 300	NH 1500-P
MAXIMUM FLOW RATE	l/h	70	550
MAXIMUM BOILER OUTPUT	kW	300	1500
MANOMETRIC HEAD	m	-	3
STAGNATION HEIGHT	mm	95	90
NEUTRALIZING MATERIAL		Calcium carbonate	Calcium carbonate
DURATION OF NEUTRALIZING MATERIAL		12 months (1500 working hrs)	12 months (1500 working hrs)
DIMENSIONS (L x W x H)	mm	410x310x220	670X470X280
INLET/OUTLET CONNECTIONS	mm	25	25 / 10
INLET/OUTLET HEIGHT	mm	30/100	30
OVERFLOW HEIGHT	mm	-	100
ELECTRICAL CONNECTION		-	230V/50Hz
ABSORBED ELECTRICAL POWER	W	-	74
ABSORBED CURRENT	A	-	0,33
PROTECTION DEGREE		-	IP 54

RECHARGE:
Neutralizing material 25 kgs: Refill NH

Dimensions

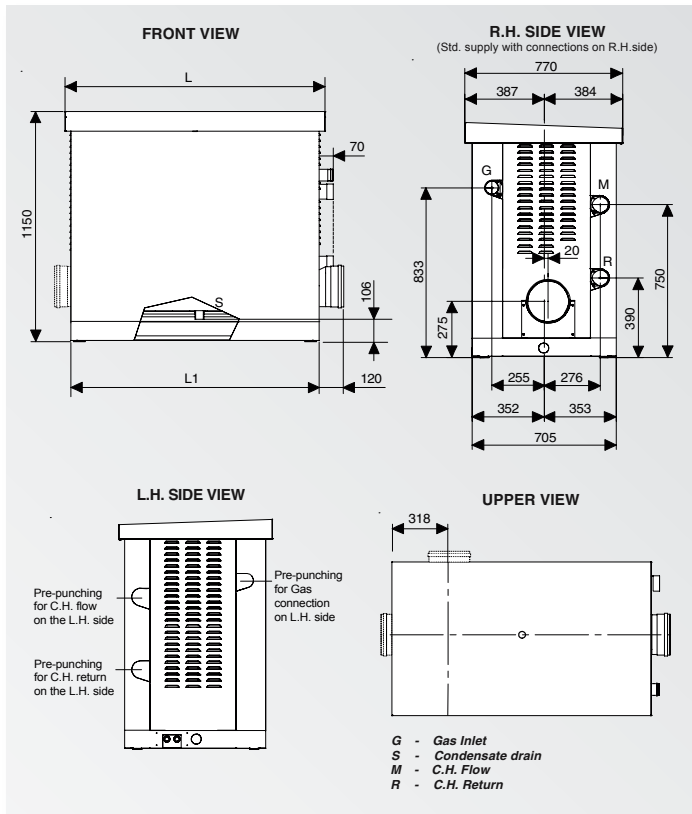

MODULEX EXT 100÷350

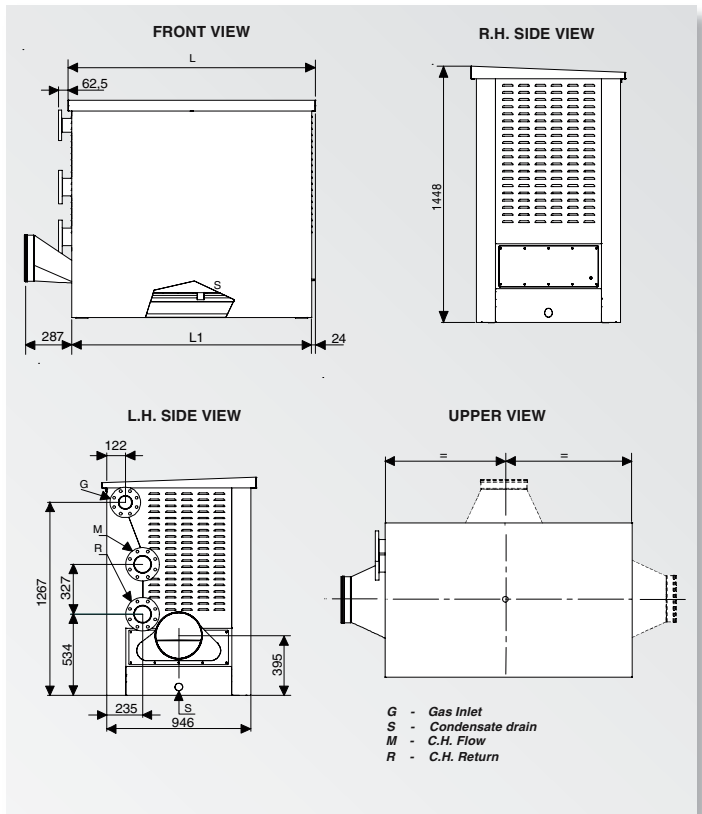

MODULEX EXT 440÷900

Technical data

MODULEX EXT		100	150	200	250	300	350	440	550	660	770	900
NOMINAL INPUT on N.C.V.	kW	100	150	200	250	300	348	432	540	648	756	864
NOMINAL OUTPUT in condensation 30° / 50°C	kW	100,1	150	200,4	251,3	302,7	354,6	445	557,8	670,1	783,2	900,3
MINIMAL INPUT in condensation 30° / 50°C	kW	12,5	12,5	12,5	12,5	12,5	12,5	23,9	23,9	23,9	23,9	23,9
NOMINAL OUTPUT in std. conditions 60° / 80°C	kW	97,2	146,1	195,2	244,5	294	342,2	424,35	530,44	636,53	742,62	849,05
EFFICIENCY CLASS (directive EEC 92/42)		★★★★	★★★★	★★★★	★★★★	★★★★	★★★★	★★★★	★★★★	★★★★	★★★★	★★★★
WATER EFFICIENCY at nom. load in condensation	%	100,1	100,8	100,2	100,5	100,9	101,9	104	104	104	104	104
WATER EFFICIENCY at part load in condensation	%	106,8	106,8	106,8	106,8	106,8	106,8	109	109	109	109	109
MAX. CONDENSATE PRODUCTION	kg/h	15,3	23	30,6	38,3	45,9	53,6	73,4	91,7	110	128,4	146,7
NO _x EMISSIONS (pondered value according to EN 15420)	mg/kWh	53,8	53,8	53,8	53,8	53,8	53,8	49	49	49	49	49
WATER CONTENT	l	10,1	14,2	18,3	22,4	26,5	30,6	67	80	94	108	122
Min.-Max WATER PRESSURE	bar	0,5 - 6	0,5 - 6	0,5 - 6	0,5 - 6	0,5 - 6	0,5 - 6	0,5 - 6	0,5 - 6	0,5 - 6	0,5 - 6	0,5 - 6
WIDTH (L)	mm	764	764	1032	1032	1300	1300	1087	1355	1355	1623	1623
WIDTH (L1)	mm	706	706	974	974	1242	1242	1039	1307	1307	1575	1575
CHIMNEY CONNECTION	mm	150	150	150	200	200	200	250	250	300	300	300
GAS CONNECTION	G	mm (inch)	50 (2)	50 (2)	50 (2)	50 (2)	50 (2)	80 (3)	80 (3)	80 (3)	80 (3)	80 (3)
C.H. FLOW / RETURN	M / R	mm (inch)	64 (2½)	64 (2½)	64 (2½)	64 (2½)	64 (2½)	100 (4)	100 (4)	100 (4)	100 (4)	100 (4)
PROTECTION DEGREE	IP	X5D	X5D	X5D	X5D	X5D	X5D	X5D	X5D	X5D	X5D	X5D
MAXIMUM ABSORBED POWER	W	145	210	290	362	435	507	626	783	940	1096	1252
STAND-BY CONSUMPTION	W	10	10	10	10	10	10	20	20	20	20	20
GROSS WEIGHT	kg	203	236	295	325	386	419	585	643	707	806	858

Unical

