

※DIMENSION IN MILLIMETER

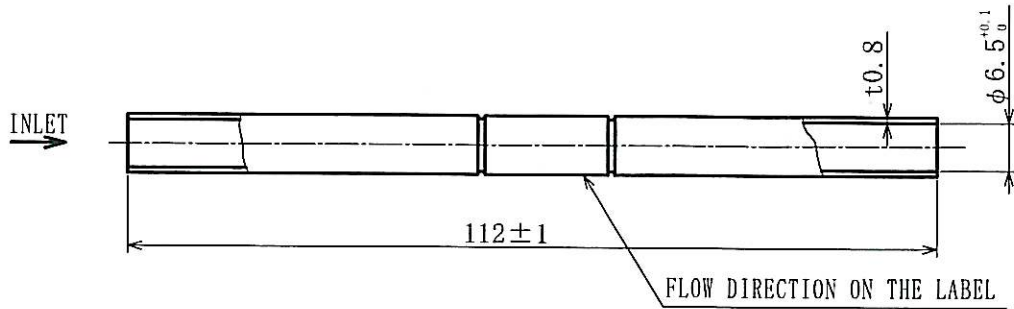

SPECIFICATION

- | | |
|--------------------------------|---|
| 1. BURST PRESSURE | : 18MPa |
| 2. WATER TEST PRESSURE | : 6.75MPa |
| 3. AIRTIGHT PRESSURE | : 4.5MPa |
| 4. MAX. WORKING PRESSURE | : 4.5MPa |
| 5. FLUID | : R134a, R22, R404A, R407C, R410A, R507A |
| 6. ALLOWABLE FLUID TEMPERATURE | : -30~+120°C |
| 7. MIN. OPENING PRESSURE | : 0.0078MPa or LESS |
| 8. VALVE LEAKAGE | : 300cm ³ /min. or LESS WITH AIR UNDER
ΔP=0.98MPa |
| 9. FLOW | : 3 L/min. WITH WATER UNDER: ΔP=0.039MPa
(MEAN C _v VALUE; 0.33) |
| 10. VALVE LIFE | : SHOULD SATISFY SPEC. 7, 8, 9 AFTER TESTING
100,000 TIMES UNDER ΔP=1.47MPa (AIR). |
| 11. MOUNTING POSITION | : ANY POSITION. (ATTENTION TO BE PAID TO THE VARIATION
OF THE SHUT-OFF FLOW VOLUME. PIPING TO BE MADE IN
VIEW OF THE CLAUSE 12.) |
| 12. SHUT-OFF FLOW VOLUME | : 7.9 L/min WITH AIR ON THE HORIZONTAL LINE.
11.5 L/min WITH AIR ON THE VERTICAL LINE FROM THE INLET
THROUGH THE OUTLET IN DESCENDING ORDER.
0 L/min WITH AIR ON THE VERTICAL LINE FROM THE INLET
THROUGH THE OUTLET IN ASCENDING ORDER (FREE FALLING
OF THE VALVE SEAT) NO REFRIGERANT OIL IS TAKEN IN
CONSIDERATION TO THE ABOVE FIGURES. |

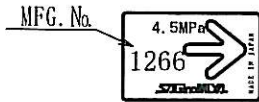

CAUTIONS

1. THE CENTER PORTION TO BE KEPT COOL ENOUGH DURING SOLDERING WITH WET RAGS AND WATER, AND THE SOLDERING TO BE MADE IN SHORT TIME.
2. NITROGEN GAS TO BE APPLIED ON SOLDERING IN ORDER TO PREVENT OXIDIZED SCALES THAT MAY CAUSE VALVE LEAK.
3. BEFORE INSTALLATION, CLEAN INSIDE OF THE PIPES AND REMOVE DUST OR FOREIGN MATTER.
4. CAUTION THAT IT MIGHT BE NOT APPLICABLE IN SOME CASE OF HAVING REMARKABLE PULSATION OF REFRIGERANT AND/OR COMBINING FOLLOWING TEMPERATURE AND PRESSURE CONDITIONS IN REFRIGERATION / AIR CONDITIONING SYSTEM.

APPLIED MOMENTARILY OPERATION PRESSURE DIFFERENTIAL MORE THAN 2MPa AT CLOSING THE VALVE, UNDER HIGH TEMPERATURE OF EXCEEDING 100°C.

5. WE MANUFACTURE THE PRODUCT BASED ON THE SPECIFICATIONS DESCRIBED IN THIS DRAWING. PLEASE CHECK THE SAFETY AND VALIDITY IN THE PRODUCT DESIGN IN CONSIDERATION THAT THE PRODUCT IS CONFORMED TO THE SYSTEM OR NOT WHEN USING.

NORDICOLD

Approved by	Date JAN. 26 2006	Name CHECK VALVE	
Designed by	Scale 1:1	Catalog Number BCV-302DYQ84	Drawing Number N-CV-51240
Drawn by	SAGINOMIYA SEISAKUSHO, INC.		