

ACTIVA INC.

**SPECIFICATION
SHEET**



MODEL NO. :	D9225V24HB-K-IP54
DESCRIPTION :	DC COOLING FAN
VERSION :	A
RELEASED DATE :	2017.07.25

APPROVED BY	PREPARED BY
<i>Clouder Hsia</i>	<i>Ken Lee</i>
2019.05.28	2019.05.28

SYMBANG



ACTIVA INC.

9F-1,472, Chung San 2nd Road, Kaohsiung 800, Taiwan, R.O.C.
Tel: 886-7-2824356 Fax: 886-7-2414287 E-Mail: info@symbang.com.tw
Web Site: <http://www.activa.com.tw> <http://www.symbang.com.tw>

ACTIVA INC.

PRODUCT SPECIFICATION

A. General Specification

Item		Specification		Condition
1	Model No.	D9225V24HB-K-IP54		
2	Outline Dimension	92 x 92 x 25 mm		
3	Rated Voltage	DC 24 V		
4	Operating Voltage Range	DC 14 ~ 26.4 V		
5	Start Voltage	DC 14 V		
6	Rated Current	0.15	A	At Rated Voltage, 25°C, 65% RH, Free Air
7	Power Consumption	3.6	W	
8	Rotating Speed	3200	RPM ±10%	At Rated Voltage, 25°C, 65% RH, Free Air
9	Max. Airflow	58.30	CFM	At Rated Voltage AMCA 210 Standard
		1.65	m ³ /min	
10	Max. Static Pressure	4.70	mmH ₂ O	At Rated Current
		0.18	inchH ₂ O	
11	Noise Level	38	dB(A)	At Rated Voltage Measured in a non-echo Chamber CNS 8753 Standard ISO 3744 Test Condition
12	Life	50,000hrs	at 25°C	MTTF (Mean Time To Failures) at Confidence. Level 90%
13	No. of Blade	7	Blades	
14	No. of Pole	4	Poles	
15	Rotating Direction	Clockwise View From Label Side		
16	Weight	80	g	
17	Motor Type	DC Brushless Fan Motor		
18	Protection Degree(IP)	IP54		

ACTIVA INC.

B. Main Materials / Parts Specification

Materials / Parts		Specification
1	Housing	Thermoplastic PBT, UL94V-0
2	Blade	Thermoplastic PBT, UL94V-0
3	Bearing	Ball Bearing
4	Termination	Lead Wire Red(+),Black(-), Yellow(FG) UL1007 AWG#26 Length:300±10mm

C. Safety Approvals

Safety Approvals	UL	TUV	
File Number	N/A	N/A	

D. Environmental Specification

Item		Specification / Condition
1	Operating Temp. Range	Temperature : -10°C ~ + 60°C Humidity : 65% ±20% RH
2	Storage Temperature	All function shall be normal after 500 hours storage at -40°C to +75 °C with a 24 hour recovery period at room temperature.
3	Humidity Test	After 96 hours, 95% RH, 40+/-2°C per MIL-STD-202F, method 103B humidity test, the measured data on insulation resistance and dielectric strength shall meet the specification.
4	Thermal Shock	Per MIL-STD 202F Method 107D, Condition D
5	Insulation Shock	Class A

E. Electrical Specification

Item		Specification/Condition
1	Insulation Resistance	10MΩ/Between unshielded wire and frame at 500 VDC\min
2	Dielectric Strength	5mA Max./Measured b\w lead wire (+) and frame at 500 VAC\min
3	Motor Safety Protection	Open circuit when VCC&GND are exchanged Circuit won't be burned within 5seconds when VCC&GND are exchanged
4	Locked rotor Protection	Built-in controller will begin to motivate the fan motor to get it start rotating again when the fan speed suddenly drops to zero in a stuck state.

ACTIVA INC.

F. Outline Dimension

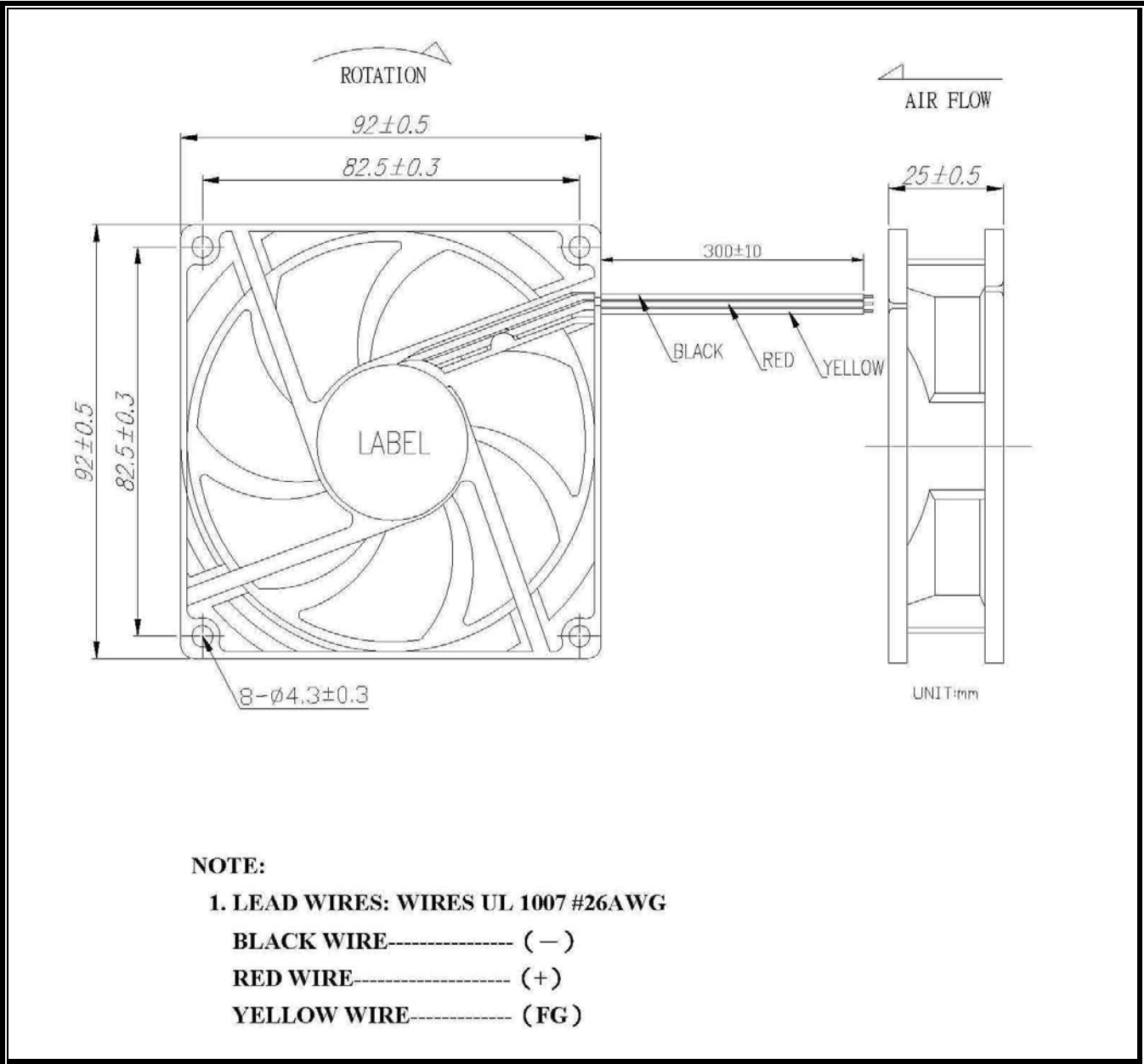

G. Airflow Performance

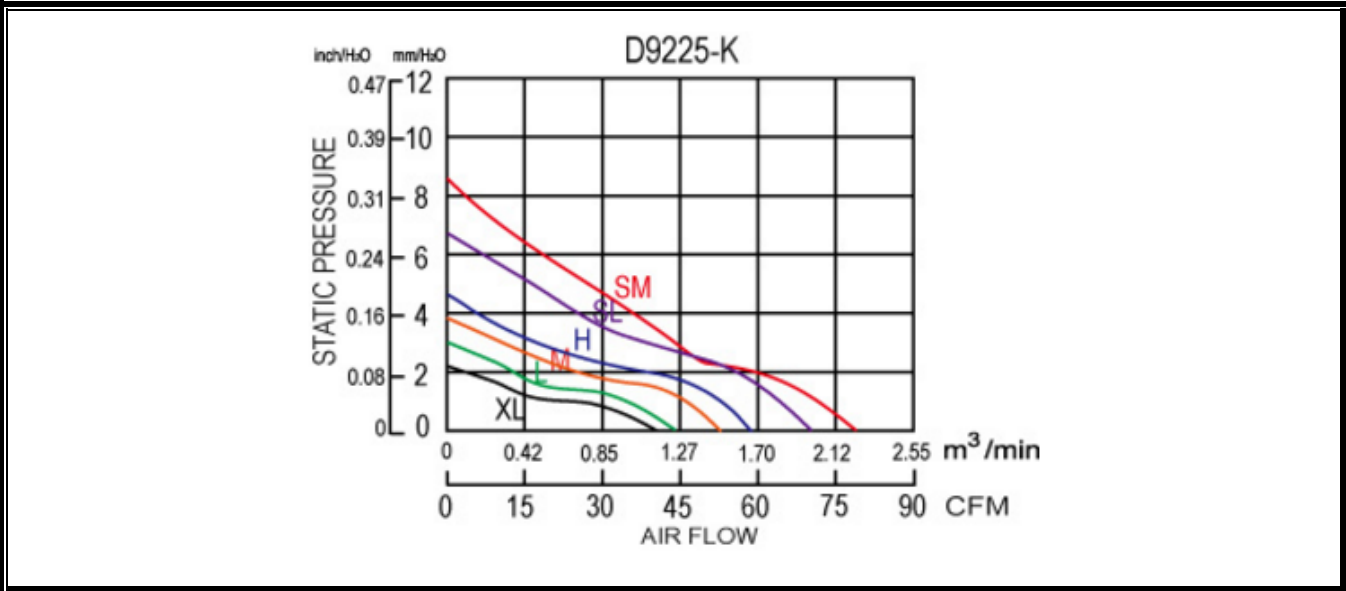

ACTIVA INC.

H. Notes:

1. All specifications are measured after 5 min. rotating. Activa will not assume responsibility for Performance of products if application condition is outside of parameters stated forth in the specification.
2. A written request should be submitted to Activa prior to approval if abnormality and deviation from This specification is required.
3. Please be cautious when fan is being exercised or handled. Applying pressure to the impeller, handling The fan by lead wire or dropping the fans to the production platform is resulting in damage.
4. The operating voltage and temperature were defined after fan rotating continually at rated voltage.
5. If fan was stocked at an ambient temperature under 5°C and over 24 hrs. Please stock fans to an Ambient temperature over 20°C and remained over 24 hrs before using. All specifications include Abnormal noise has to be measured after 30 minute running.
6. Noise Level is different from abnormal noise. Please send abnormal samples to Activa to analyze. We estimate noise level by equation when noise level is lower than background noise (17dB).
7. Starting Voltage was defined on power on/off condition. Rotational speed was defined on full speed By it's rated value.
8. The correct polarity, Positive (+) and Negative (-), has to be clearly identified before connecting the fan to the power. Be aware of the connection with reverse polarity may lead to damage since no effective Protection can be introduced against such errors.
9. L10 of Life test is a deductive value under statistical method and it is different from product warranty.
10. All general specifications and quality values are measured under condition of free air and fan vertical Set up. Activa highly suggests practicing a test when fan apply to a special application.
11. with exception of suitability of some particular designs, any failure and problems regarding safety of The product caused by the introduction of powder, droplets of water or encroachment of insert in the Hub is not guaranteed.
12. Activa fans are not well suited for corrosive environments. This includes liquids, gases, or matters.
13. Except for the feature of the Lock Rotor Protection specifically stated, this feature is not applied to all Fans. Activa highly suggests not stopping the impellers of the working fans such interruption will Cause adverse effect.
14. Fans are to be stored in a dry/cool place. High levels of humidity are harmful to products.
15. Please be cautious. Activa is not responsible for any excess resonance, vibration and subsequent noise caused by incorrect mounting of fans.
16. Take necessary precaution handling fans when in operation. Finger guards are recommended to Prevent personal injury.
17. All test environments are conducted under the condition of relative (ambient) temperature and humidity At 25°C, 65%. The test result stated above is effective only for unique fan performance.
18. To avoid any unstable power, an "over 4.7 μ F" capacitor has definitely be connected to fan externally Whatever multiple fans are applied in parallel.
19. The above conditions are examples of extreme application. However they are very important and Should receive top priority.
20. Activa Inc has reserves the right to substitute the specification without prior notice.