

**ELECTRONIC CONTROL
DIP SWITCH STANDARD SETTING
FOR 4-017-7113
(Configurazione Iniziale Dip Switch)**

40177113 (000)

0	1	2	3	4	5	6	7	8
N								
↑								
DP4	DP5	DP6	Speed Range					
ON	ON	ON	0 - 10 V					
OFF	ON	ON	0 - 9,5 V					
ON	OFF	ON	0 - 9 V					
OFF	OFF	ON	0 - 8,5 V					
ON	ON	OFF	0 - 8 V					
OFF	ON	OFF	0 - 7,5 V					
ON	OFF	OFF	0 - 7 V					
OFF	OFF	OFF	0 - 6,5 V					

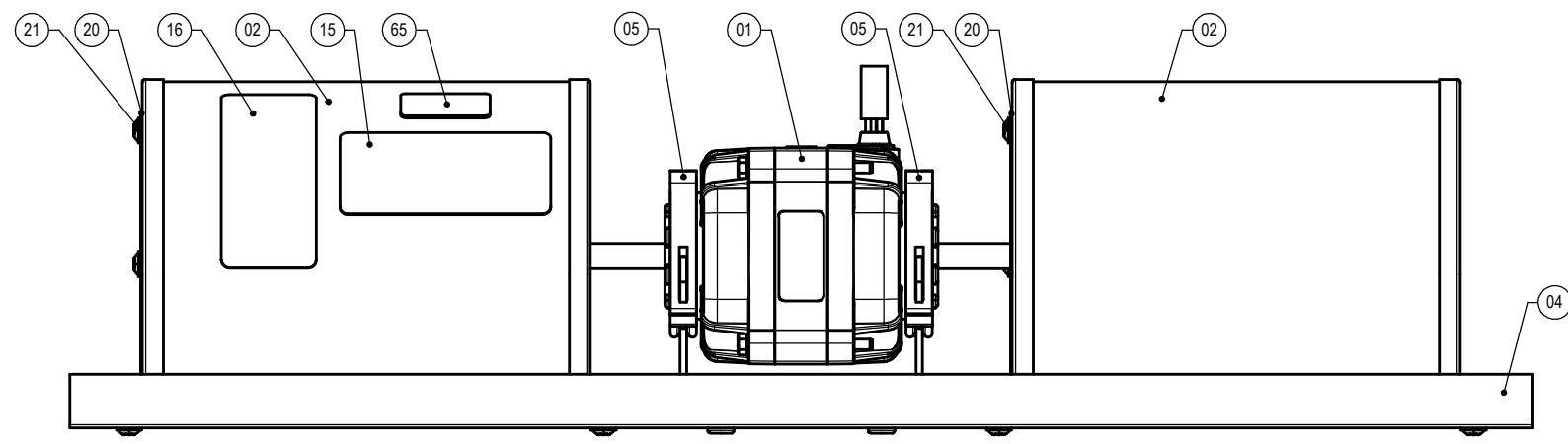

40177113 SHALL BE USED WITH CONTROLBOX 3571010/000/1

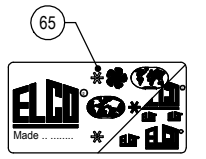

FAN-DECK BALANCING
IN ACCORDANCE
EL.UN.0082
(Equilibratura Grado :)
6.3

MOTOR (Motore)	CLASS "B" - SLEEVE BEARINGS MANUFACTURED (Classe "B" - Esecuzione a Bronzine)
HOUSING (Coclea)	GALVANIZED SHEET IRON (Lamiere Zincata)
FAN DECK SUPPORT (Supporto Gruppo Ventilante)	GALVANIZED SHEET IRON (Lamiere zincata)
BLOWERS No.2 Ø108 x 148 (Ventole N°2 Ø108 x 148)	ALUMINIUM (Alluminio con Mozzo in Acciaio)
ELECTRICAL SPECIFICATION No. (Controllo elettrico Prescrizione)	G.2328/2G

CODE : 40177113
TYPE : ECM082 40-20/CO-2-113 **CE**
230 V~ 50/60 Hz TH. PROT.
0,20 A 30 W 1350 Rpm
INS. CL. B Win@ηmax.=21
(E082T20BB0080S) DATA

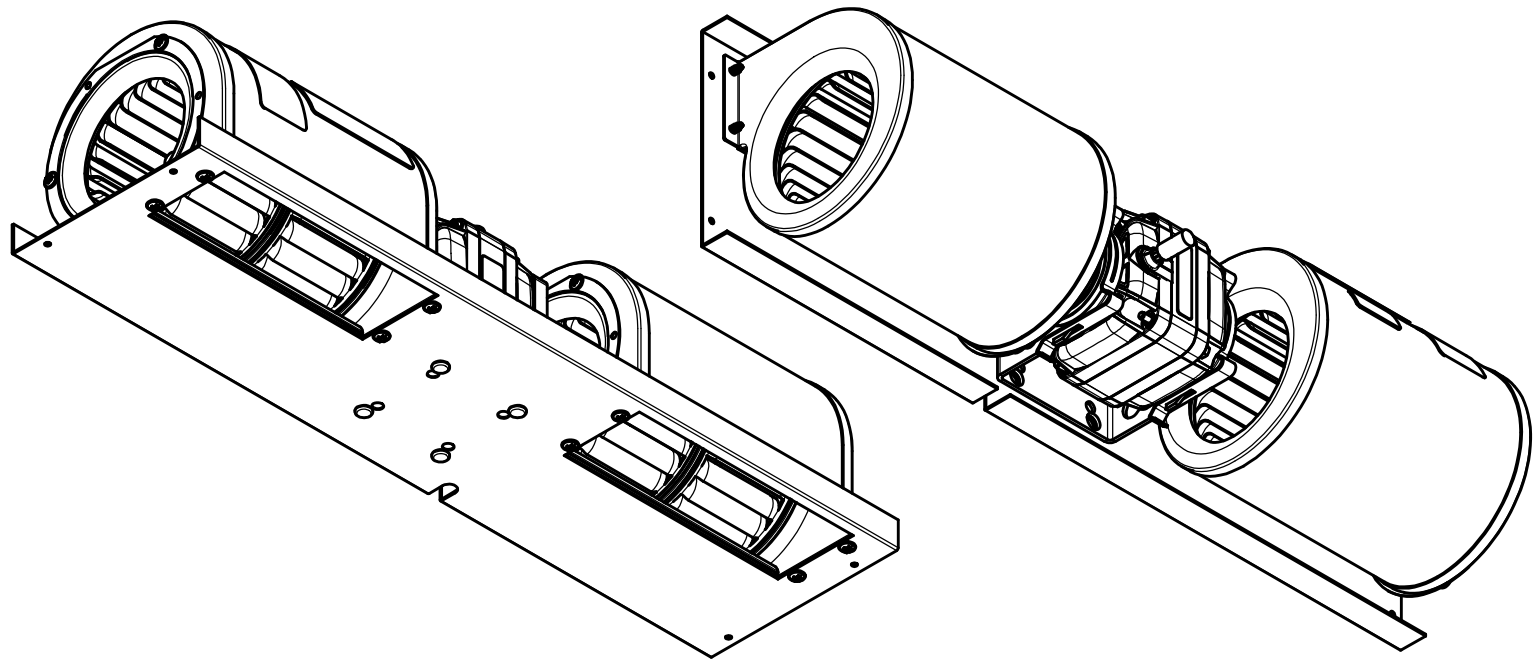

- TO TIGHTEN THE HOUSING FIXING SCREWS ON THE PLATE WITH TORQUE 15-17 Kgcm (Serrare le viti di fissaggio coclea con una coppia di 15-17 Kgcm)
- BLOWER MUST BE CENTERED IN TO THE HOUSING (Controllare la scentratura assiale della ventola , massimo consentito 2mm)
- TO LOCK BLOWER GRUB SCREWS IN ACCORDANCE EL.UN.0075 (Bloccare i grani di fissaggio delle ventole secondo normativa EL.UN.0075)

Rel	Date	Description	Executed	Checked
D	18-02-2019	MODIFICATO NOTA PER SCHEDA COMPATIBILE ERA 3571010/000 DIVENTA 3571010/000/1	Pedri R.	E. Crippa
C	13-12-2018	TOLTO CONNETTORI FORNITI A PARTE	Pedri R.	E. Crippa
B	19-09-2018	TOLTO SCHEDA FORNITA A PARTE	Pedri R.	E. Crippa
A	02-08-2016	AGGIUNTO TARGHETTA CON CODICE E CONFIGURAZIONE COMPLETA (TOLTO TARGHETTA STANDARD UGUALE PER TUTTI)	Pedri R.	E. Crippa

For dimension without tolerance see standard UNI EN 22768-mK	Treatment	A2
Material	Material	
Drawn Pedri R.	GR. VENT. 230V 50/60Hz	Weight gr.
Date 21-07-2015	TYPE : ECM082 40-20/CO-2-113	Release D
Check E. Crippa	Ref. No 40177051	
Scale ---	40177113	