

Liquid ring vacuum pumps

two-stage



SIHI® Pumps

LOH 25003, LOH 25007, LOH 25309

Pressure range: 33 to 1013 mbar
Suction volume flow: 11 to 60 m³/h

CONSTRUCTION TYPE

Sterling SIHI liquid ring vacuum pumps are displacement pumps of uncomplicated and robust construction with the following particular features:

- handling of nearly all gases and vapours
- non-polluting due to nearly isothermal compression
- oil-free, as no lubrication in the working chamber
- small quantities of entrained liquid can be handled
- easy maintenance and reliable operation
- low noise and nearly free from vibration
- wide choice of material, therefore applicable nearly everywhere
- protection against cavitation as standard
- no metallic contact of the rotating parts

Die Sterling SIHI liquid ring vacuum pumps LOH 25003, LOH 25007 and LOH 25309 are two-stage ones. They can be applied without modification as compressors (see catalogue section liquid ring compressors).

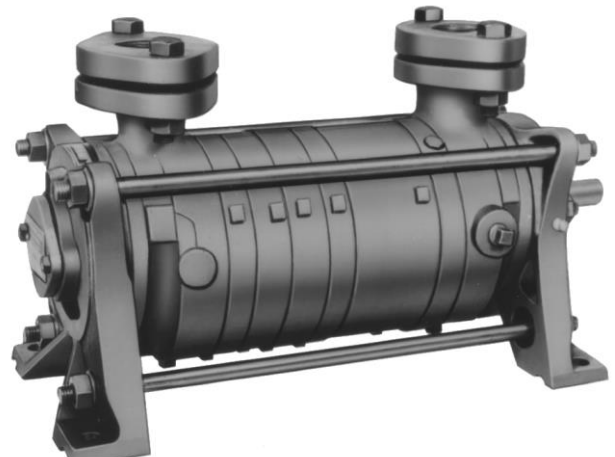

APPLICATION

Handling and exhausting of dry and humid gases; entrained liquid can be handled during normal duty. The pumps are applied in all fields where a pressure of 33 to 900 mbar must be created by robust vacuum pumps.

- Fields of application are for example:
- chemistry and pharmacy for distilling and degassing
 - electric industry for impregnation and drying
 - plastics industry for degassing etc.

NOTE

During operation the pump must continuously be supplied with service liquid, normally water, in order to eliminate the heat resulting from the gas compression and to replenish the liquid ring, because part of the liquid is leaving the pump together with the gas. The liquid can be separated from the gas in a liquid separator (see catalogue part accessories).

It is possible to reuse the service liquid.

The direction of rotation is clockwise, when looking from the drive on the pump.

GENERAL TECHNICAL DATA

Pump Type	Units	LOH 25003	LOH 25007	LOH 25309
Speed	50 Hz 60 Hz	rpm	2800 3400	2800 3400
Maximum overpressure on compression	bar	2.0		1.2
Permissible pressure difference between suction and discharge side	max. min.	bar	2.0 0.2	1.2 0.2
Hydraulic test pressure (overpressure)	bar	3		
Moment of inertia of rotating parts Of pump and water content	kg · m²	0.004	0.0065	0.00875
Noise level at 80 mbar suction pressure	dB (A)	66 67		
Minimum permissible pulley diameter for V belt drive	mm	71 80	71 80	100
Maximum gas temperature	dry saturated	°C	200 100	
Service liquid:				
maximum permissible temperature	°C	80		
minimum permissible temperature	°C	10		
maximum viscosity	mm²/s	90		
maximum density	kg/m³	1200		
liquid capacity up to middle of shaft	litre	1.0	1.2	1.4
Maximum flow resistance of the heat exchanger	bar	0.2		

In selecting a pump, avoid choosing one which is likely to be operating at a combination of its maximum permissible limits e.g. maximum viscosity and maximum permissible pressure difference.

Materials

Item	COMPONENTS	MATERIALS	
		OK	42
0001, 0002	Vacuum casing	0.6025	1.4408
0010, 0011, 0012, 0013	Guide disc / Intermediate piece		
0030, 0031	Vane wheel impeller	1.4308	1.4517
0035, 0036	Central body	1.0553	1.4571
0200	Shaft	1.4021	1.4401
0500, 0600	Mechanical seal	Cr Ni-steel / carbon / Butadiene rubber	Cr Ni Mo-steel / carbon / Viton

Cut-away diagram LOH 25003, LOH 25007, LOH 25309

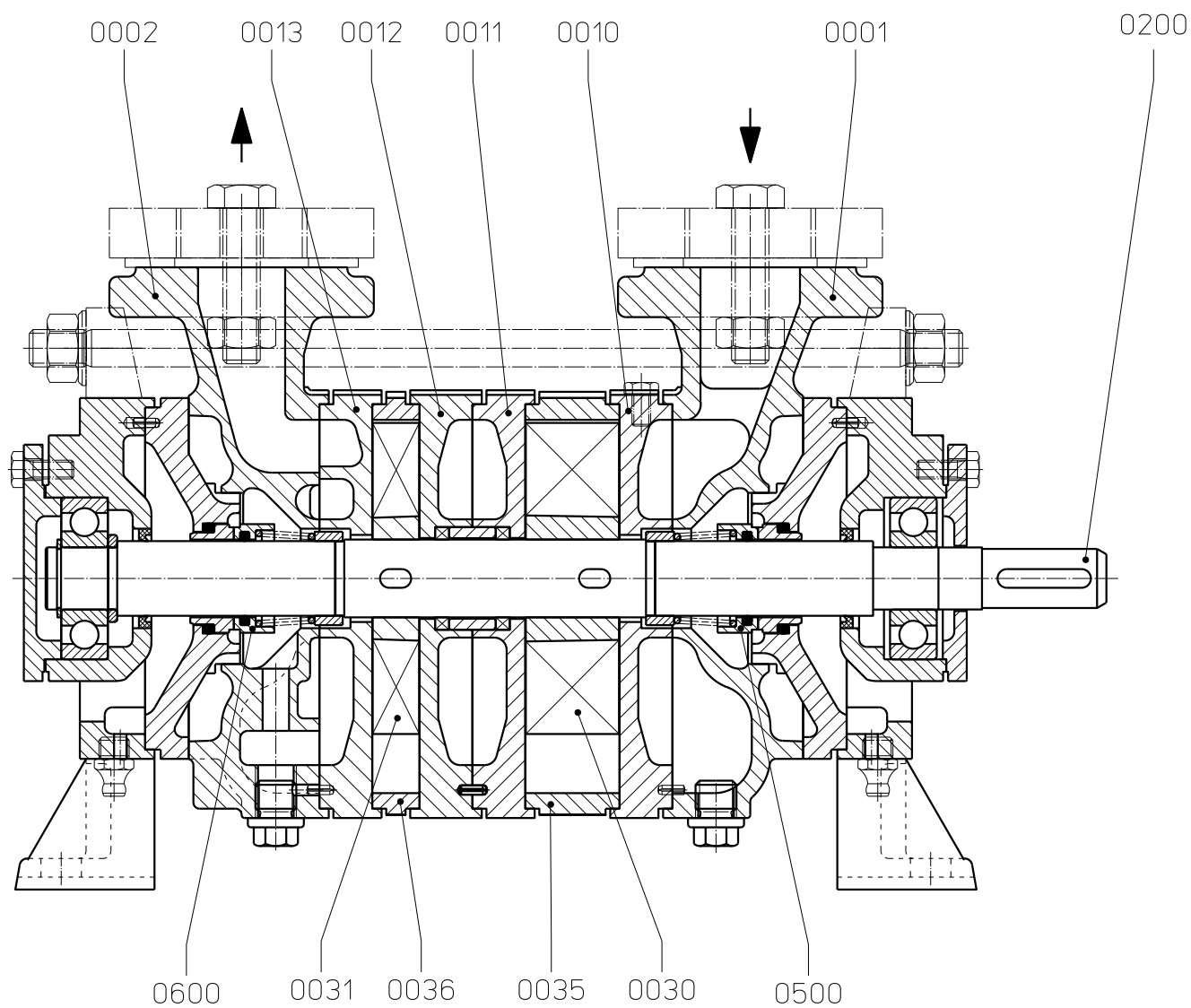

Performance Characteristics LOH 25003

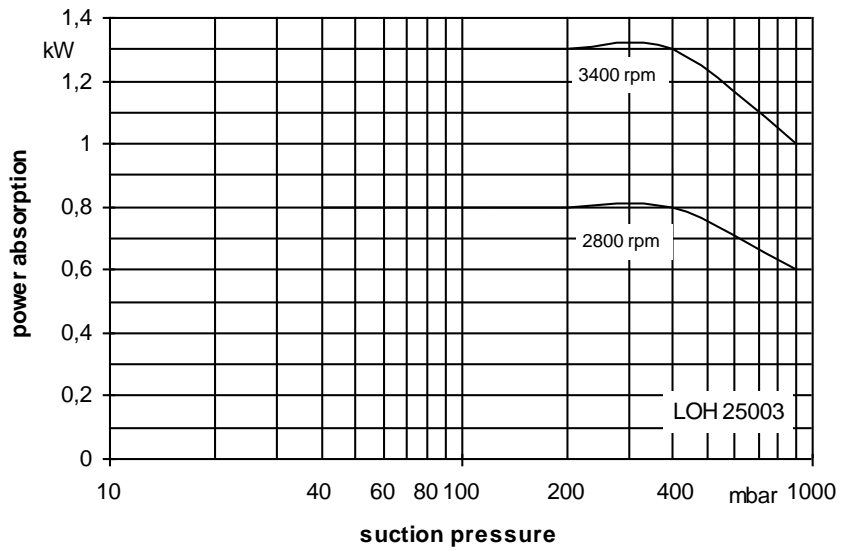
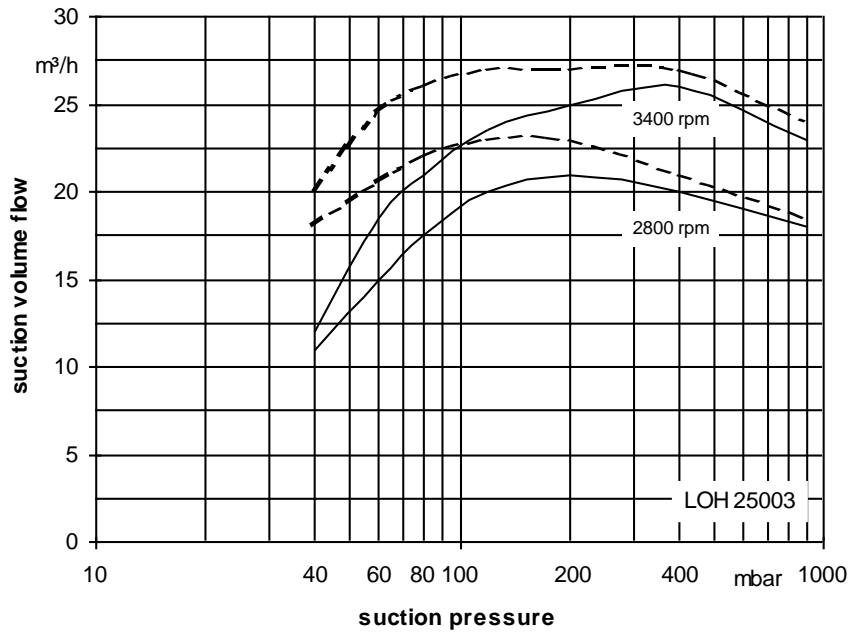

The operating data is valid under the following conditions:

- Process media:
 - dry air: 20°C _____
 - steam saturated air: 20°C - - - - -
- Service liquid:
 - water: 15°C

Pressure of gas to be evacuated: 1013 mbar (Atmospheric pressure)

The suction volume is related to the suction pressure.

Tolerance on operating data is 10%.

The maximum consumption of make-up water occurs at the lowest suction pressure.

Performance Characteristics LOH 25007

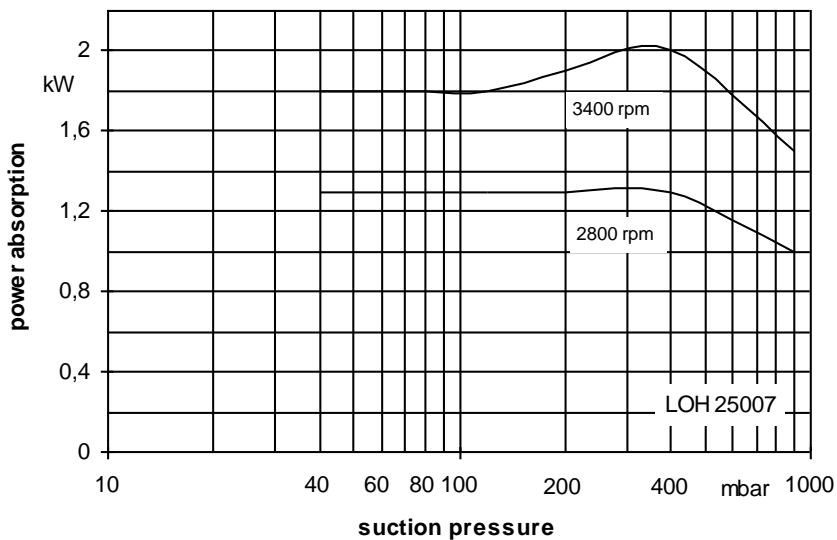
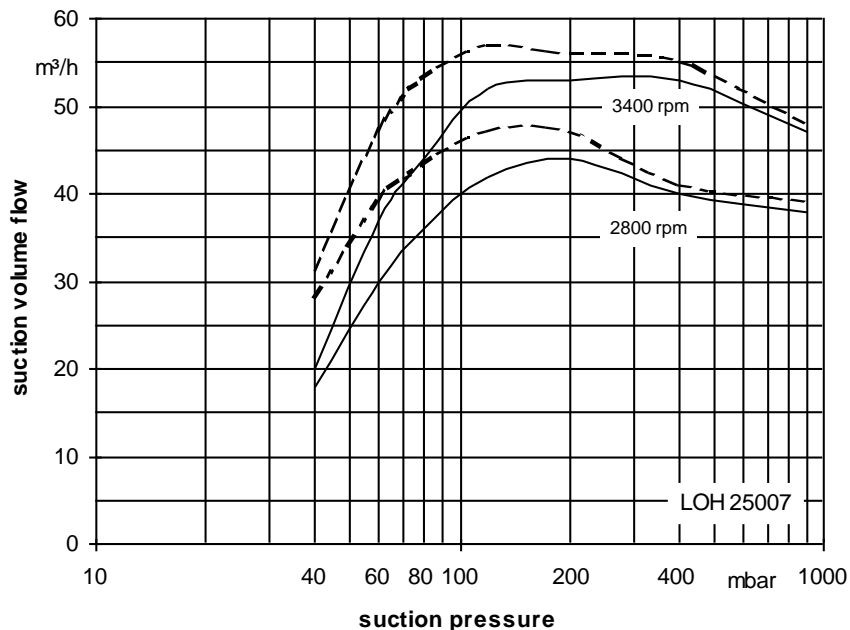

The operating data is valid under the following conditions:

- Process media:
 - dry air: 20 °C _____
 - steam saturated air: 20°C -----
- Service liquid:
 - water: 15°C

Pressure of gas to be evacuated: 1013 mbar (Atmospheric pressure)

The suction volume is related to the suction pressure.

Tolerance on operating data is 10%.

The maximum consumption of make-up water occurs at the lowest suction pressure.

Performance Characteristics LOH 25309

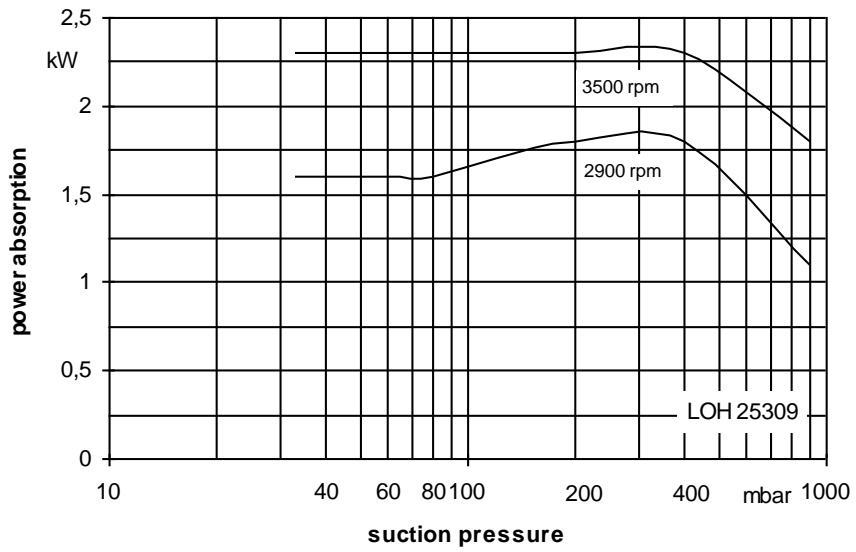
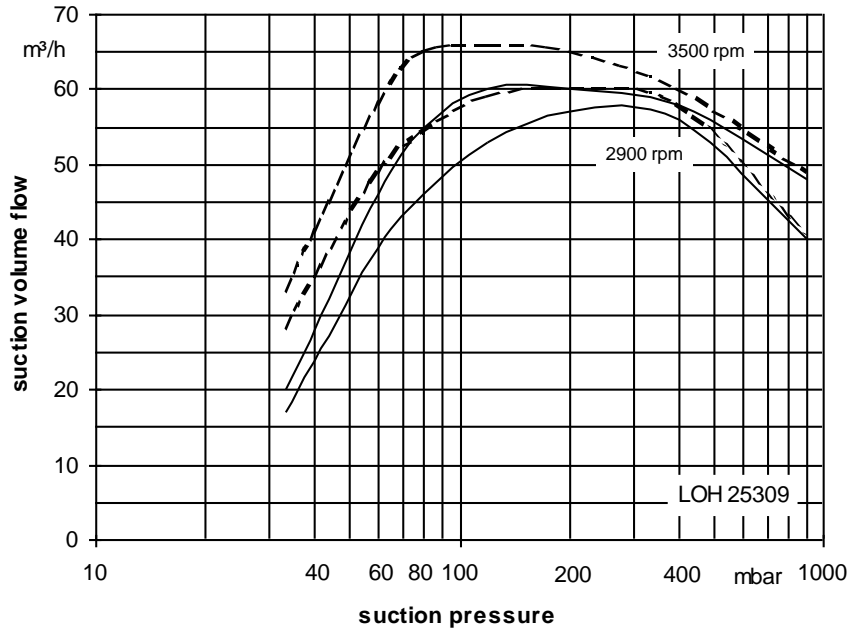

The operating data is valid under the following conditions:

- Process media:
 - dry air: 20°C —————
 - steam saturated air: 20°C - - - - -
- Service liquid:
 - water: 15°C

Pressure of gas to be evacuated: 1013 mbar (Atmospheric pressure)

The suction volume is related to the suction pressure.

Tolerance on operating data is 10%.

The maximum consumption of make-up water occurs at the lowest suction pressure.

Dimensions LOH 25003, LOH 25007

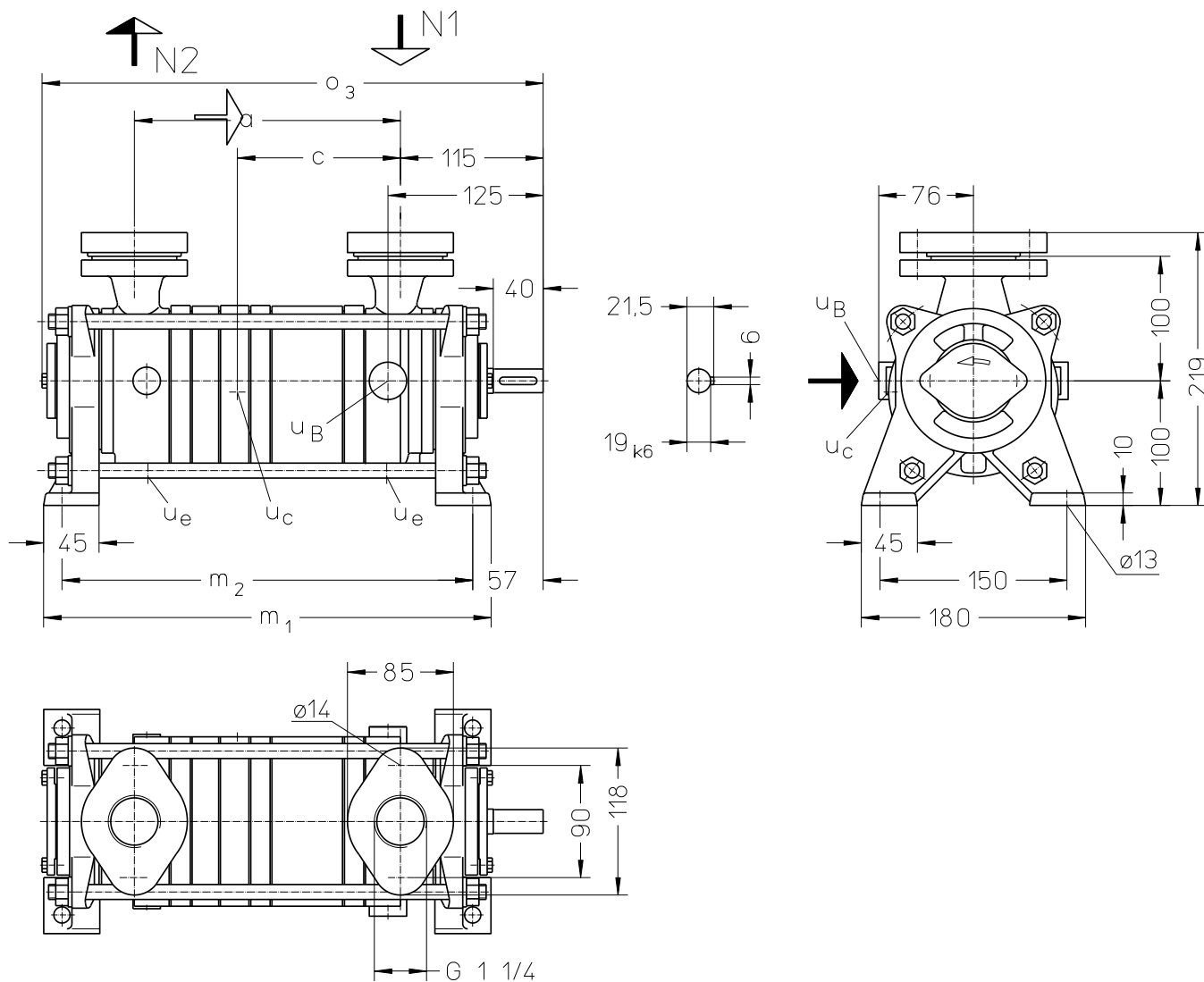

N 1 = Gas inlet G 1 ¼

N 2 = Gas outlet G 1 ¼

u B = Connection for service liquid G ¾

u c = Connection for protection against cavitation G ½

u e = Connection for drain G ¼

Oval counter flanges are part of the design.

	a	c	m 1	m 2	o 3	approx. weight [kg]
LOH 25003	163	96	309	279	348	22
LOH 25007	213	131	359	329	398	23

Arrangement drawing LOH 25003, LOH 25007 with overhead liquid separator

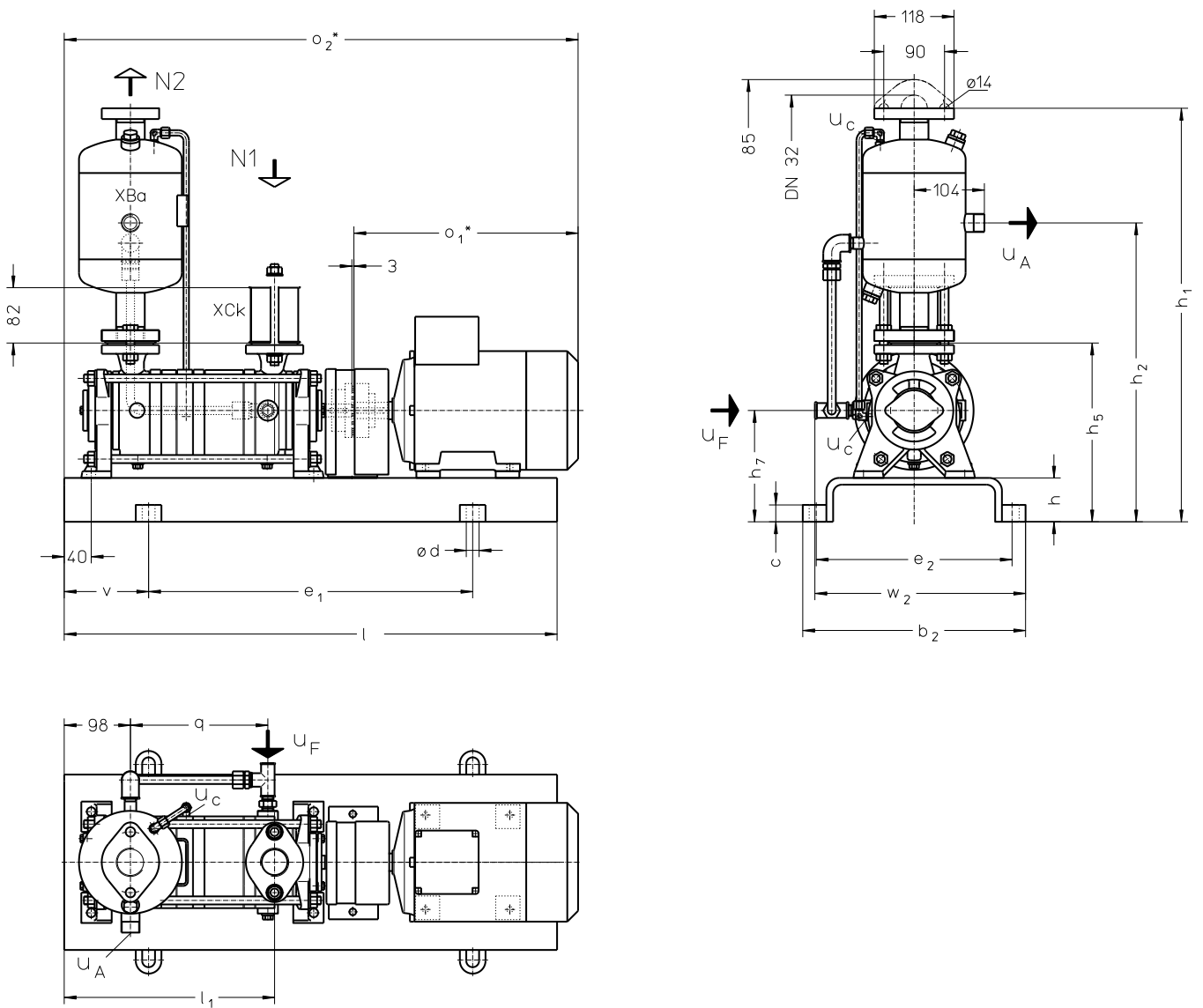

- N 1 = Gas inlet G 1 ¼
- N 2 = Gas outlet DN 32
- U A = Connection for liquid drain R ¾
- u c = Connection for protection against cavitation G 1/8
- u F = Connection for make-up liquid G 3/8

Oval flanges according to DIN 2558 PN 6

	electric motor 50 Hz			b ₂	c	d	e ₁	e ₂	h	h ₁	h ₂	h ₅	h ₇	l	l ₁	o ₁ *	o ₂ *	q	v	w ₂	approx. weight [kg]
	size	kW																			
LOH 25003	80	1.1	-	297	20	15	400	265	40	585	415	240	140	640	262	274	653	153	120	292	33
	80	-	1.1																		
LOH 25007	90S	1.5	-	330	25	19	480	290	65	610	440	265	165	730	311	332	761	204	125	312	50
	90L	-	2.0																		

* dimensions dependent upon motor supplier

Dimensions LOH 25309

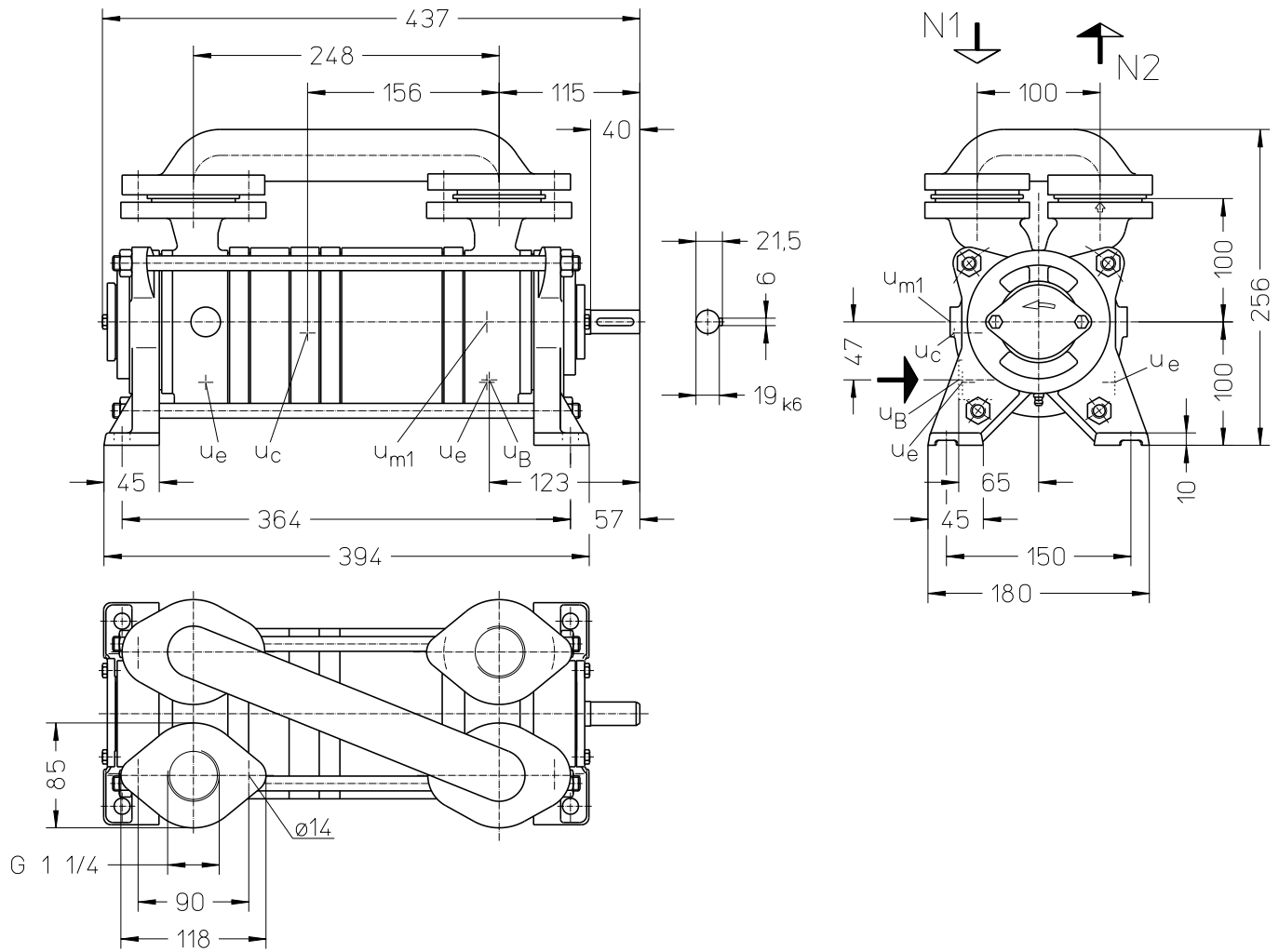

- N 1 = Gas inlet G 1 ¼
- N 2 = Gas outlet G 1 ¼
- u_B = Connection for service liquid G ½
- u_c = Connection for protection against cavitation G ⅛
- u_e = Connection for drain G ¼
- u_{m1} = Connection for drain valve G ¼

Oval counter flanges are part of the design.

Arrangement drawing LOH 25309 with overhead liquid separator

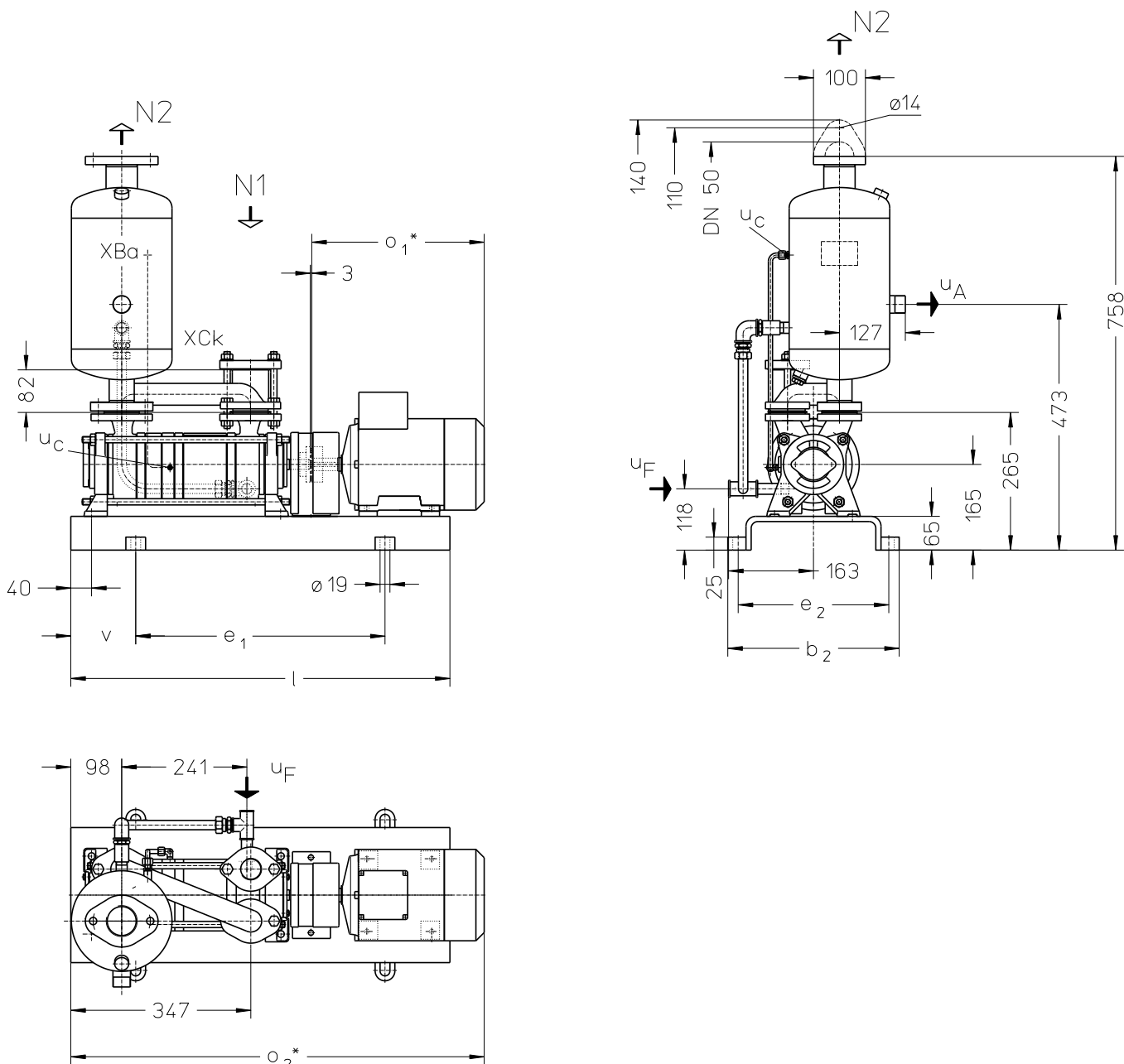

- N 1 = Gas inlet G 1 ¼
- N 2 = Gas outlet DN 50
- u A = Connection for liquid drain R 1
- u c = Connection for protection against cavitation G 1/8
- u F = Connection for make-up liquid G ½

oval flanges according to DIN 2558 PN 6

	electric motor 50 Hz			b ₂	e ₁	e ₂	l	v	o ₁ *	o ₂ *	approx. weight [kg]
	size	kW									
		IP 55	EEx e II T3								
LOH 25309	90L	2.2	-	330	480	290	730	125	332	796	57
	100L	-	2.5	360	540	320	820	140	363	827	70

* dimensions dependent upon the motor supplier

Make-up Liquid Consumption in [m³/h] dependent upon suction pressure, speed, drive type and temperature difference

Suction pressure in [mbar]		40				120				200				400						
Pump Type	Speed [rpm]	KB			FB	KB				FB	KB				FB					
		Temperature Difference [°C]				Temperature Difference [°C]					Temperature Difference [°C]									
		10	5	2		20	10	5	2		20	10	5	2		20	10	5	2	
LOH 25003	2800	0.06	0.10	0.17	0.35	0.03	0.06	0.09	0.16	0.3	0.03	0.06	0.09	0.16	0.3	0.03	0.05	0.09	0.15	0.26
	3400	0.08	0.14	0.22		0.05	0.08	0.13	0.20		0.05	0.08	0.13	0.20		0.05	0.08	0.12	0.18	
LOH 25007	2800	0.08	0.14	0.22	0.35	0.05	0.08	0.13	0.20	0.3	0.05	0.08	0.13	0.20	0.3	0.05	0.08	0.12	0.18	0.26
	3400	0.11	0.16	0.24		0.06	0.10	0.15	0.22		0.06	0.11	0.16	0.22		0.06	0.10	0.15	0.20	
LOH 25309	2900	0.12	0.20	0.36	0.75	0.07	0.12	0.21	0.36	0.71	0.07	0.13	0.21	0.36	0.68	0.07	0.12	0.20	0.32	0.55
	3500	0.16	0.27	0.47	0.90	0.09	0.16	0.27	0.46	0.86	0.09	0.16	0.27	0.45	0.82	0.09	0.15	0.25	0.39	0.65

FB = Total service liquid flow rate on once-through system

KB = Flow of make-up water when combined with partial recirculation liquid at a temperature 20 °C, 10 °C, 5 °C, 2 °C warmer than make-up water

Product Code - order details

range + size	bearings + sense of rotation	shaft seal	materials	casing sealing
	<ul style="list-style-type: none"> • B two grease lubricated antifriction bearing • N one shaft end clockwise rotating 	131, X0A mechanical seal	0K main parts out of cast iron, impellers in low alloyed steel 42 main parts out of stainless steel	0 liquid sealing
LOH 25003 25007 25309	BN	131, X0A	0K, 42	0

Motor Selection

For our products we offer a lot of different motor types. To identify the right motor please specify frequency, voltage and protection class.

Example of an Order:

LOHE 25007 BN 131 0K 0 with 1.5 kW AC motor, 50 Hz, 230V Δ, IP55

Accessories

Recommended Accessory	Material Execution		LOH 25003	LOH 25007	LOH 25309
Top Mounted Liquid Separator		Type / Weight	XBa 342 / 6 kg		XBa 1041 / 10 kg
Top mounted separator	1.4571	SIHI-Part No.	43 132 176		35 000 394
Service liquid pipework	Steel, galvanised 1.4571	SIHI-Part No.	20 054 559 20 054 560		20 054 886 20 054 887
Cavitation protection pipework	Steel, galvanised 1.4571	SIHI-Part No.	20 050 509 20 050 512	20 050 510 20 050 513	20 050 511 20 050 514
SIHI – Gas Ejector see Technical Catalogue – Gas ejector at service liquid temperature 15+30 °C		Type Weight	-	GOV 3211 3.5 kg resp. 4 kg	GOV 3212 3.5 kg resp. 4 kg
SIHI – Non Return Ball Valve					
Intermediate flange execution XCK 32	0.6025 + Butadiene rubber 0.6025 + Teflon 1.4408 + Teflon	SIHI-Part No. Weight	20 072 744 / 1.2 kg 20 072 769 / 1.3 kg 20 085 240 / 3.3 kg		
Flange execution with glass cylinder XCK 324	0.6025 + Butadiene rubber 0.6025 + Teflon	SIHI-Part No. Weight	20 072 832 / 7.0 kg 20 072 833 / 7.0 kg		
Motor					
Motor Standard execution IP 55		Size Power Weight	80 B 1.1 kW 10 kg	90 S 1.5 kW 13 kg	90 L 2.2 kW 15 kg
Coupling for Motor IP 55 Pump side Motor side		Type / Weight SIHI-Part No. SIHI-Part No.	B 80 / 1.5 kg 43 021 409 43 021 420 43 039 231 43 039 231		
Coupling guard	Steel	SIHI-Part No.	43 042 201		
Baseplate	Steel	Type / Weight SIHI-Part No.	S 008 / 10 kg 43 040 648	S 241 / 23.5 kg 43 040 631	
Motor					
Motor in EEx e II T3 execution		Size Power Weight	80 B 1.1 kW 12 kg	90 L 2 kW 16 kg	100 L 1.1 kW 12 kg
Coupling for Motor EEx e II T3 Pump side Motor side		Type / Weight SIHI-Part No. SIHI-Part No.	BDS 88 / 2 kg 43 111 026 43 111 034 43 111 055 43 111 029		
Coupling guard	Brass	SIHI-Part No.	43 042 202		
Baseplate	Steel	Type / Weight SIHI-Part No.	S 008 / 10 kg 43 040 648	S 241 / 23.5 kg 43 040 631	S 272 / 28.3 kg 43 040 633

Any changes in the interest of the technical development are reserved.

Sterling SIHI GmbH

Lindenstraße 170, D-25524 Itzehoe, Germany, Telephone +49 (0) 48 21/ 7 71 - 01, Fax +49 (0) 48 21/ 771-274