

**resideo**

Product information

Protection module type AB for liquid category 5 according to SS-EN 1717. Complete unit ready for installation with modular construction, frequency-controlled centrifugal pump and buffer tank.

Dimension range (DN)	350 - 540
----------------------	-----------

PN	16
----	----

Temperature (°C)	5 - 40
------------------	--------

Material	Plastic
----------	---------

Area of use

To protect the internal and external drinking water systems against backflow and pressure backflow, a protective cover for liquid up to category 5 is required. The backflow prevention is of type AB in accordance with SS-EN 1717. It meets the requirements for connecting drinking water to: flushing at sewage treatment plants, agriculture, flushing and cleaning of sanitary equipment within hospitals or other applications where an air gap is required.

Tender text

PSG.261 Backflow preventers with air gap

Backflow prevention device AT 1162-1..., protective module type AB with buffer tank for protection of liquid category 5 according to SS-EN 1717. Made with a polyethylene tank, volume 350 - 540 litres. High-pressure pump with flow rate of 7.0 - 43.0 m³/h and pressure of 1.5 - 8.0 bar.

Quality assurance

Fluid category 5, SS-EN 1717

The product is CE marked

The backflow prevention device is designed according to DIN 1988-500. It meets the requirements of the Swedish National Board of Housing, Building and Planning's Building Regulations (BBR) for water supply installations. It complies with SS-EN 1717 as a protection module type AB for liquid category 5. The unit is CE marked.

Product marking: Information about the year of manufacture, manufacturing number, model, electrical data, IP rating, as well as pressure/flow, are specified on the unit's nameplate. CE marked.

Energy and environment declaration

Reach date: 6/14/2023 12:00:00 AM

Pos	Component	Material
-----	-----------	----------

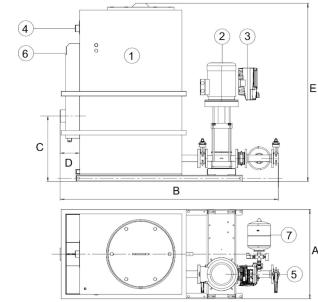

Measurements and weight

Dimension range (DN): 350 - 540

DN	A	B	C	D	E
32	800	1543	587	175	1185
50	800	1965	587	175	1600
65	800	1990	587	175	1600

Function and design

Backflow prevention device type AB covers the risks up to liquid category 5 when connecting tap water. That is, "Liquid that poses a health risk due to the presence of microorganisms or viruses." The air gap in the module meets the standard requirements.

Fully automatic unit with modular design including high-pressure pump, frequency converter, pressure equalization tank, and buffer tank. The system is started and regulated by pressure. The flow is controlled via the frequency converter. If the preset pressure is undershot, the pump starts, and the frequency converter regulates the unit to the set value so that a constant pressure is always available. The flow decreases when consumption decreases, and the unit is turned off after a specified minimum run time (0 to 600 seconds, standard setting is 60 seconds).

The water level in the buffer tank is measured with two level switches. On the outlet side, there is a pressure equalization tank, pressure sensor, and pressure gauge. The overflow has an integrated siphon protection and can be connected directly to the drain.

Variable speed compact pressure boosting unit with:

- A normally suctioning, vertical high-pressure rotary pump with all components in contact with the medium
- High-efficiency motor with frequency converter, energy efficiency class IE4 according to IEC-CD 60034 - 30 ED. 2
- Check valve
- Shut-off valve on the inlet and outlet side
- Membrane expansion tank on the outlet side as a tank
- Pressure transmitter on the pressure side
- Vibration dampers between pump and base frame
- Display of pressure gauge
- Lockable shut-off valve
- Pipelines
- The system is connected to the installation pipeline with G1 1/4", G2", or G2 1/2" (depending on version)
- Base frame
- Stainless steel
- Coated steel

2. Self-cooling frequency converter adapted to the motor
- See the instructions for the frequency converter

3. Buffer tank:

- Non-circular, free overflow according to EN13077, Type AB
- Drainage connection with integrated water trap:
DN100 for CBU146-32A-060 and CBU146-40A060
DN150 for CBU146-50A-060, CBU146-65A-060, CBU146-65B-060, and CBU146-80B-060
- Tank volume according to DIN 1988-500 or individually approved
- Replenishment of drinking water via float valve, suitable for drinking water

Components not shown

The connection cabinet consists of:

- Power supply connection via 3/N/PE, AC 400V, 50Hz
- Lockable main switch for emergency stop (repair switch)
- LED, green for normal function, yellow for warning, red for alarm, and description text in the display.
- Motor protection device (included in the frequency converter)
- Connection list/clamps with labels for all connections
- Plug connectors for easy connection to the electrical equipment mounted in the supply container

Messages that can be sent via potential-free contact for

- Alarms and warnings
- Indicator for pump operation

Technical data

Head (m): 81 - 100

Material: Plastic

Included materials: Cast iron, Stainless steel, Steel, Plastic, Rubber

Material note: See instruction manual.

Temperature (°C): 5 - 40

PN: 16

ETIM classification: EC004501 - Backflow preventer

TECHNICAL CHARACTERISTICS

Pressure drop characteristics

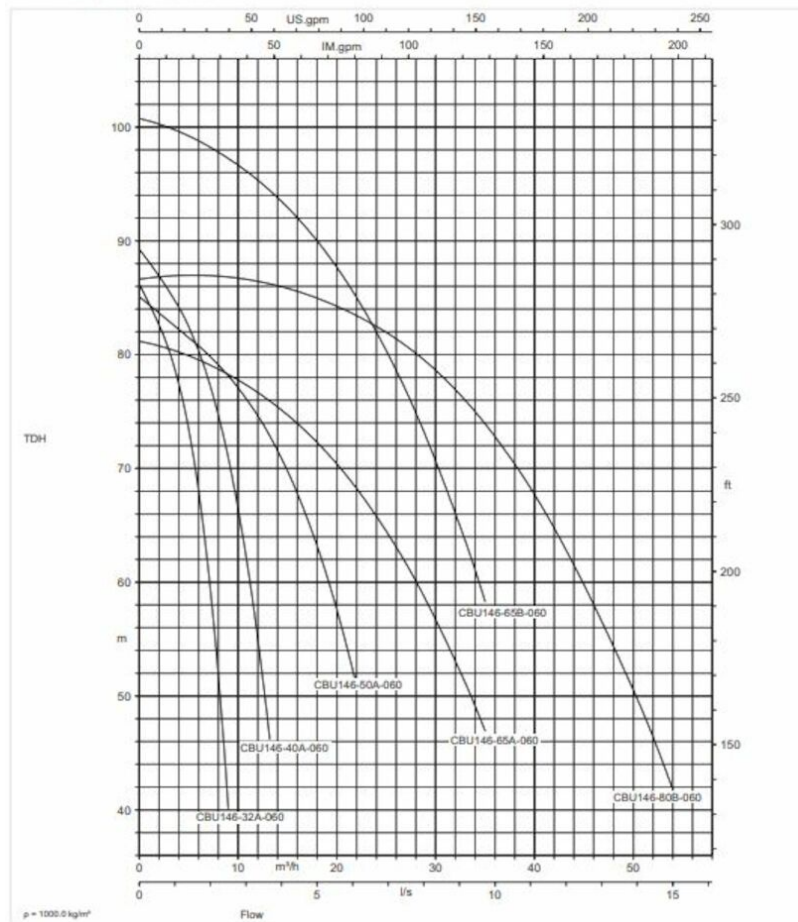

Installation and maintenance

The device shall be maintained according to the manufacturer's instructions. For more information, please refer to the user manual.

Please feel free to contact us

We answer your questions by e-mail and telephone. No question is too small, no challenge is too big. You are always welcome at Armatec.

info@armatec.se | +46 31 89 01 00 | www.armatec.se

THE COMPANY'S MANAGEMENT SYSTEM
IS CERTIFIED BY DNV
ISO 9001 • ISO 14001