



**Type 431**  
**Plain lever H3**  
**Open bonnet**  
**Conventional design**

# Type 431, 433

Type 433

## Flanged Safety Relief Valves - spring loaded



**Type 433**  
**Cap H2**  
**Closed bonnet**  
**Conventional design**

### Contents

### Chapter/Page

#### Materials

- Conventional design 01/02
- Balanced bellows design 01/04

#### How to order

- Numbering system 01/06
- Article numbers 01/08

#### Pressure temperature ratings

- Metric units 01/10

#### Dimensions and weights

- Metric units 01/12

Approvals 01/13

Flange drillings 01/14

Flange facings 01/15

Order information - spare parts 01/16

Available options 01/18

#### Capacities

- Steam [Metric units] 01/19
- Air [Metric units] 01/20
- Water [Metric units] 01/21

Determination of coefficient of discharge  $K_{dr}/\alpha_w$  01/22

# Type 431, 433

LESER

How to order – article numbers

Type 433

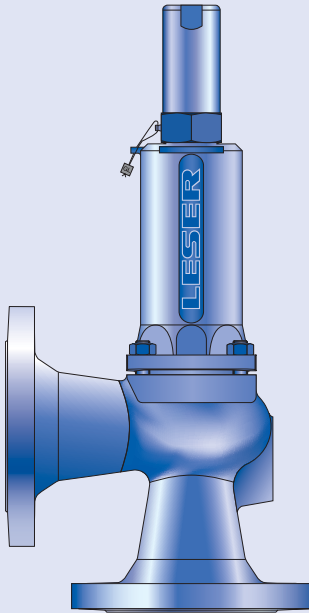

**Type 433**  
Cap H2  
Closed bonnet  
Conventional design

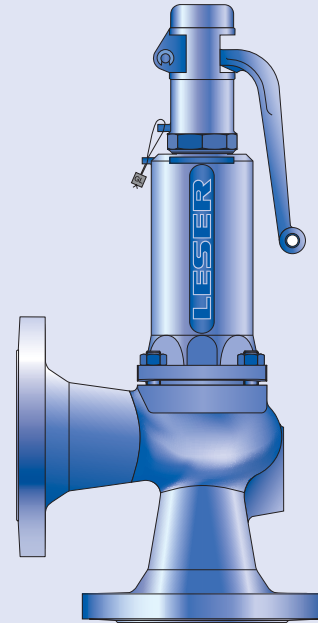

**Type 433**  
Plain lever H3  
Closed bonnet  
Conventional design

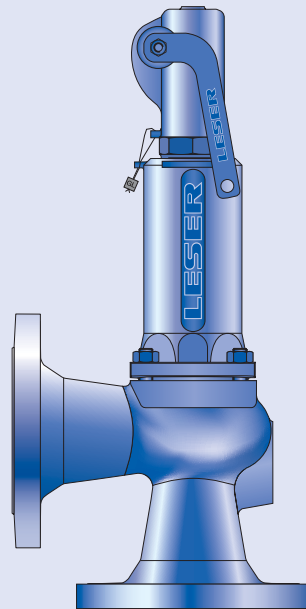

**Type 433**  
Packed lever H4  
Closed bonnet  
Conventional design

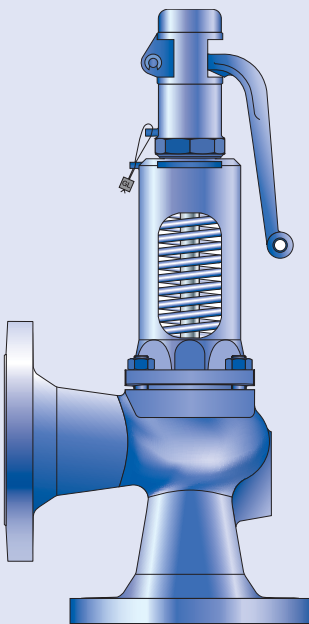

**Type 431**  
Plain lever H3  
Open bonnet  
Conventional design

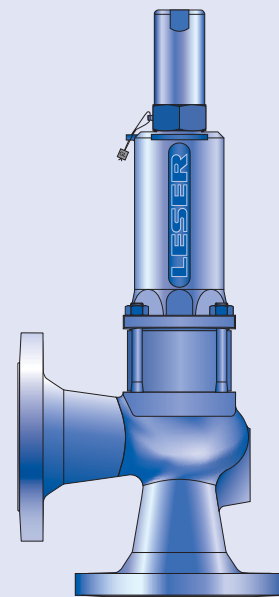

**Type 433**  
Cap H2  
Closed bonnet  
Balanced bellows design

## How to order – article numbers

Article numbers														
		O-ring disc	Metal disc											
DN <sub>i</sub>		15	15	20	25	32	40	50	65	80	100	125	150	
DN <sub>o</sub>		15	15	20	25	32	40	50	65	80	100	125	150	
Actual orifice diameter d <sub>o</sub> [mm]		12	12	18	18	18	23	29	37	46	60	74	92	
Actual orifice area A <sub>o</sub> [mm <sup>2</sup> ]		113	113	254	254	254	416	661	1075	1662	2827	4301	6648	
<b>Body material: 0.6025 (cast iron)</b>														
Bonnet closed	H2	Art. no. 4331.	8502	3992	4012	4022	4032	4042	4052	4062	4072	4082	-	-
	H3	Art. no. 4331.	8503	3993	4013	4023	4033	4043	4053	4063	4073	4083	-	-
	H4	Art. no. 4331.	8504	3994	4014	4024	4034	4044	4054	4064	4074	4084	-	-
open	H3	Art. no. 4311.	8505	3995	4015	4025	4035	4045	4055	4065	4075	4085	-	-
<b>Body material: 0.7043 (Ductile Gr. 60-40-18)</b>														
Bonnet closed	H2	Art. no. 4335.	8532	8752	8762	8772	8782	8792	8802	8812	8822	8832	-	-
	H3	Art. no. 4335.	8533	8753	8763	8773	8783	8793	8803	8813	8823	8833	-	-
	H4	Art. no. 4335.	8534	8754	8764	8774	8784	8794	8804	8814	8824	8834	-	-
open	H3	Art. no. 4315.	8535	8755	8765	8775	8785	8795	8805	8815	8825	8835	-	-
<b>Body material: 1.0619 (WCB)</b>														
Bonnet closed	H2	Art. no. 4332.	8512	4122	4142	4152	4162	4172	4182	4192	4202	4212	4222	4232
	H3	Art. no. 4332.	8513	4123	4143	4153	4163	4173	4183	4193	4203	4213	4223	4233
	H4	Art. no. 4332.	8514	4124	4144	4154	4164	4174	4184	4194	4204	4214	4224	4234
open	H3	Art. no. 4312.	8515	4125	4145	4155	4165	4175	4185	4195	4205	4215	4225	4235
<b>Body material: 1.4408 (CF8M)</b>														
Bonnet closed	H2	Art. no. 4334.	8522	4252	4272	4282	4292	4302	4312	4322	4332	4342	-	-
	H4	Art. no. 4334.	8524	4254	4274	4284	4294	4304	4314	4324	4334	4344	-	-

# Type 431, 433

## Conventional design

Type 433

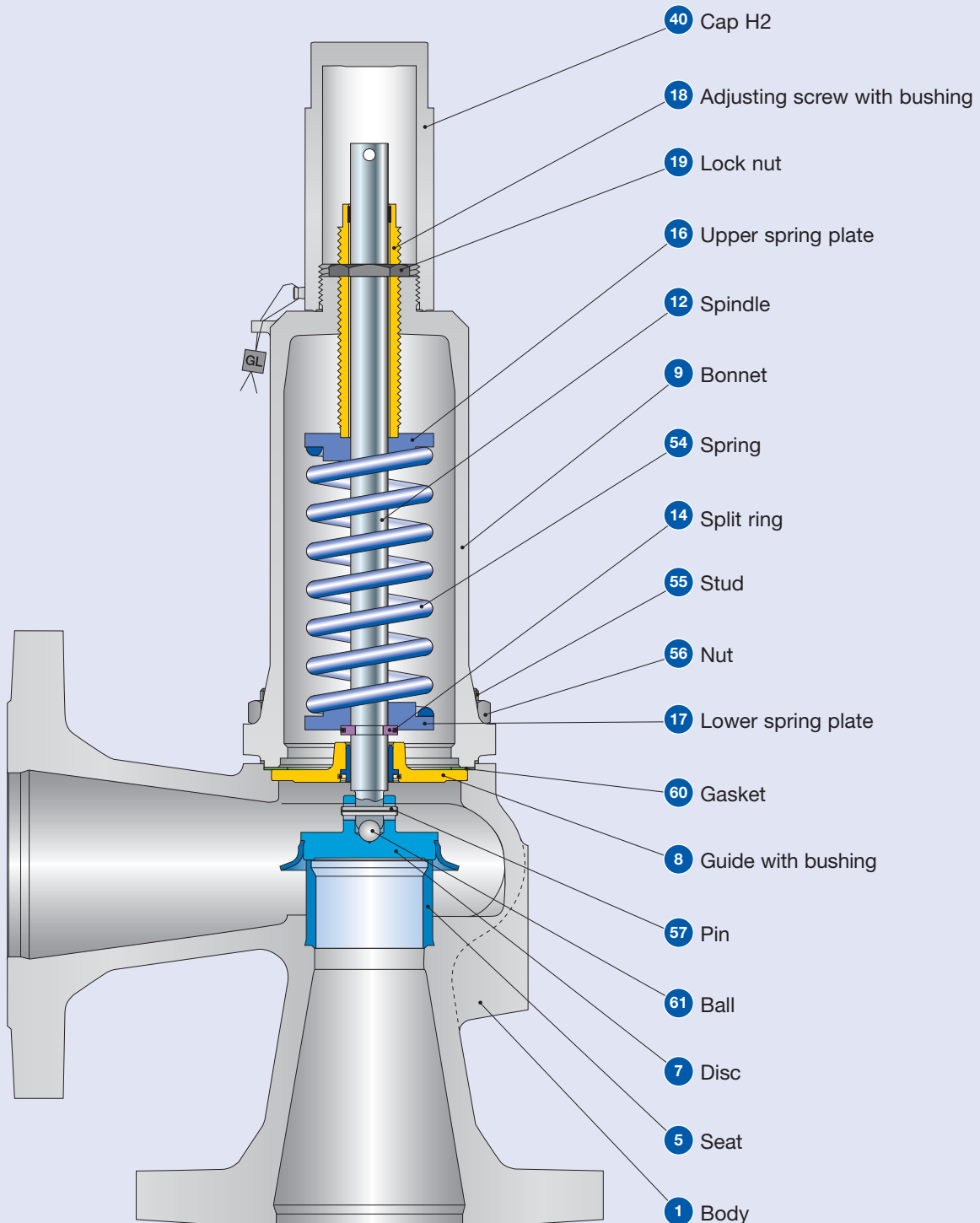

## Conventional design

Materials					
Item.	Component	Type 4311 / 4331	Type 4315 / 4335	Type 4312 / 4332	Type 4334
<b>1</b>	<b>Body</b>	0.6025	0.7043	1.0619	1.4408
		Cast iron	Ductile Gr. 60-40-18	SA 216 WCB	SA 351 CF8M
<b>5</b>	Seat	1.4404	1.4404	1.4404	1.4404
		316L	316L	316L	316L
<b>7</b>	Disc	1.4122	1.4122	1.4122	1.4404
		Hardened stainless steel	Hardened stainless steel	Hardened stainless steel	316L
<b>8</b>	Guide	1.4104, 1.0501	1.4104, 1.0501	1.4104, 1.0501, 1.0570	1.4404
		Chrome or carbon steel	Chrome or carbon steel	Chrome or carbon steel	316L
	with bushing	1.4104 tenifer	1.4104 tenifer	1.4104 tenifer	–
		Chrome steel tenifer	Chrome steel tenifer	Chrome steel tenifer	–
<b>9</b>	<b>Bonnet</b>	0.7040	0.7040	0.7040	1.4408, 1.4404
		Ductile Gr. 60-40-18	Ductile Gr. 60-40-18	Ductile Gr. 60-40-18	SA 351 CF8M, SA 479 316L
<b>12</b>	Spindle	1.4021	1.4021	1.4021	1.4404
		420	420	420	316L
<b>14</b>	Split ring	1.4104	1.4104	1.4104	1.4404
		Chrome steel	Chrome steel	Chrome steel	316L
<b>16/17</b>	Spring plate	1.0718	1.0718	1.0718	1.4404
		Steel	Steel	Steel	316L
<b>18</b>	Adjusting screw with bushing	1.4104 PTFE	1.4104 PTFE	1.4104 PTFE	1.4404 PTFE
		Chrome steel PTFE	Chrome steel PTFE	Chrome steel PTFE	316L PTFE
<b>19</b>	Lock nut	1.0718	1.0718	1.0718	1.4404
		Steel	Steel	Steel	316L
<b>40</b>	<b>Cap H2</b>	1.0718	1.0718	1.0718	1.4404
		12L13	12L13	12L13	316L
<b>54</b>	Spring, standard	1.1200, 1.8159, 1.7102	1.1200, 1.8159, 1.7102	1.1200, 1.8159, 1.7102	1.4310
		Carbon steel	Carbon steel	Carbon steel	Stainless steel
	Spring, optional	1.4310	1.4310	1.4310	–
		Stainless steel	Stainless steel	Stainless steel	–
<b>55</b>	Stud	1.1181	1.1181	1.1181	1.4401
		Steel	Steel	Steel	B8M
<b>56</b>	Nut	1.0501	1.0501	1.0501	1.4401
		2H	2H	2H	8M
<b>57</b>	Pin	1.4310	1.4310	1.4310	1.4310
		Stainless steel	Stainless steel	Stainless steel	Stainless steel
<b>60</b>	Gasket	Graphite / 1.4401	Graphite / 1.4401	Graphite / 1.4401	Graphite / 1.4401
		Graphite / 316	Graphite / 316	Graphite / 316	Graphite / 316
<b>61</b>	Ball	1.3541	1.3541	1.3541	1.4401
		Hardened stainless steel	Hardened stainless steel	Hardened stainless steel	316

**Please note:**

- LESER reserves the right to make changes.
- LESER may use higher quality materials without giving prior notice.
- Each component can be constructed of another material according to the customer's specification.
- All components exposed to pressure are highlighted in bold. The material will be specified according to DIN and ASTM here.

## Balanced bellows design

Type 433

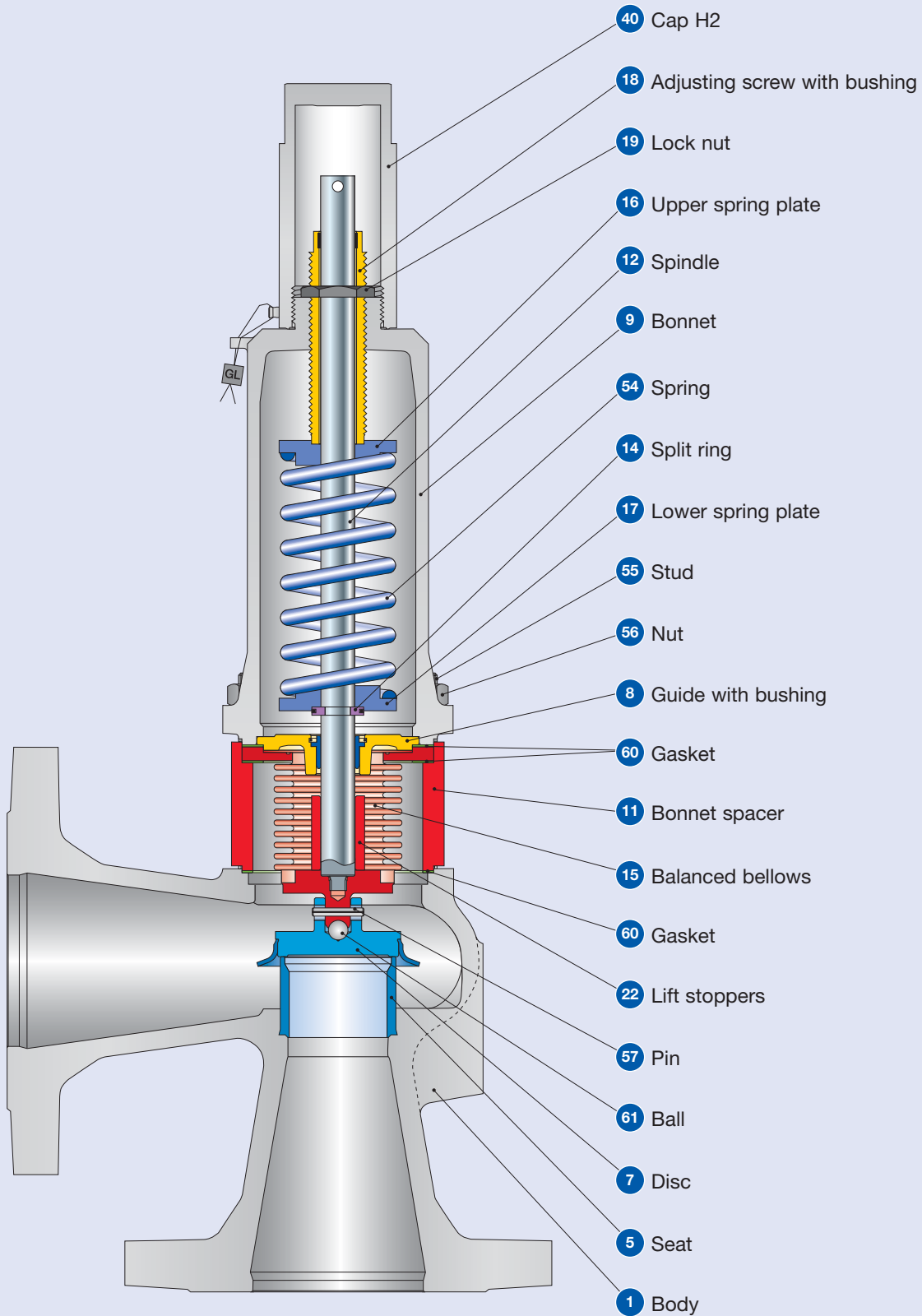

## Balanced bellows design

Materials					
Item.	Component	Type 4311 / 4331	Type 4315 / 4335	Type 4312 / 4332	Type 4334
<b>1</b>	<b>Body</b>	0.6025	0.7043	1.0619	1.4408
		Cast iron	Ductile Gr. 60-40-18	SA 216 WCB	SA 351 CF8M
<b>5</b>	Seat	1.4404	1.4404	1.4404	1.4404
		316L	316L	316L	316L
<b>7</b>	Disc	1.4122	1.4122	1.4122	1.4404
		Hardened stainless steel	Hardened stainless steel	Hardened stainless steel	316L
<b>8</b>	Guide	1.4104, 1.0501	1.4104, 1.0501	1.4104, 1.0501, 1.0570	1.4404
		Chrome or stainless steel	Chrome or stainless steel	Chrome or stainless steel	316L
	with bushing	1.4104 tenifer	1.4104 tenifer	1.4104 tenifer	–
		Chrome steel	Chrome steel	Chrome steel	–
<b>9</b>	<b>Bonnet</b>	0.7040	0.7040	0.7040	1.4408, 1.4404
		Ductile Gr. 60-40-18	Ductile Gr. 60-40-18	Ductile Gr. 60-40-18	SA 351 CF8M, SA 479 316L
<b>11</b>	Bonnet spacer	1.4404	1.4404	1.4404	1.4404
		316L	3316L	316L	316L
<b>12</b>	Spindle	1.4404	1.4404	1.4404	1.4404
		316L	316L	316L	316L
<b>14</b>	Split ring	1.4104	1.4104	1.4104	1.4404
		Chrome steel	Chrome steel	Chrome steel	316L
<b>15</b>	Balanced bellows	1.4571	1.4571	1.4571	1.4571
		316Ti	316Ti	316Ti	316Ti
<b>16/17</b>	Spring plate	1.0718	1.0718	1.0718	1.4404
		Steel	Steel	Steel	316L
<b>18</b>	Adjusting screw with bushing	1.4104 PTFE	1.4104 PTFE	1.4104 PTFE	1.4404 PTFE
		Chrome steel PTFE	Chrome steel PTFE	Chrome steel PTFE	316L PTFE
<b>19</b>	Lock nut	1.0718	1.0718	1.0718	1.4404
		Steel	Steel	Steel	316L
<b>22</b>	Lift stoppers	1.4404	1.4404	1.4404	1.4404
		316L	316L	316L	316L
<b>40</b>	<b>Cap H2</b>	1.0718	1.0718	1.0718	1.4404
		12L13	12L13	12L13	316L
<b>54</b>	Spring, standard	1.1200, 1.8159, 1.7102	1.1200, 1.8159, 1.7102	1.1200, 1.8159, 1.7102	1.4310
		Chrome steel	Chrome steel	Chrome steel	Stainless steel
	Spring, optional	1.4310	1.4310	1.4310	–
		Stainless steel	Stainless steel	Stainless steel	–
<b>55</b>	Stud	1.4401	1.4401	1.4401	1.4401
		B8M	B8M	B8M	B8M
<b>56</b>	Nut	1.4401	1.4401	1.4401	1.4401
		8M	8M	8M	8M
<b>57</b>	Pin	1.4310	1.4310	1.4310	1.4310
		Stainless steel	Stainless steel	Stainless steel	Stainless steel
<b>60</b>	Gasket	Graphite / 1.4401	Graphite / 1.4401	Graphite / 1.4401	Graphite / 1.4401
		Graphite / 316	Graphite / 316	Graphite / 316	Graphite / 316
<b>61</b>	Ball	1.3541	1.3541	1.3541	1.4401
		Hardened stainless steel	Hardened stainless steel	Hardened stainless steel	316

**Please note:**

- LESER reserves the right to make changes.
- LESER may use higher quality materials without giving prior notice.
- Each component can be constructed of another material according to the customer's specification.
- All components exposed to pressure are highlighted in bold. The material will be specified according to DIN and ASTM here.

## Pressure temperature ratings

### Metric units

		O-ring disc	Metal disc											
	DN <sub>i</sub>	15	15	20	25	32	40	50	65	80	100	125	150	
	DN <sub>o</sub>	15	15	20	25	32	40	50	65	80	100	125	150	
	Actual orifice diameter d <sub>0</sub> [mm]	12	12	18	18	18	23	29	37	46	60	74	92	
	Actual orifice area A <sub>0</sub> [mm <sup>2</sup> ]	113	113	254	254	254	416	661	1075	1662	2827	4301	6648	
<b>Body material: 0.6025 (cast iron)</b>														
<b>DIN flange</b>	Inlet		<b>PN 16</b>										-	-
	Outlet		<b>PN 16</b>										-	-
<b>Minimum set pressure</b>	p [bar <sub>g</sub> ] S/G/L	0,3	0,3	0,2	0,2	0,2	0,2	0,2	0,2	0,2	0,2	0,2	-	-
<b>Min. set pressure<sup>1)</sup></b> Standard bellows	p [bar <sub>g</sub> ] S/G/L	3,0	3,0	3,0	3,0	3,0	3,0	3,0	3,0	3,0	3,0	3,0	-	-
<b>Min. set pressure</b> low pressure Bellow	p [bar <sub>g</sub> ] S/G/L	-	-	2,0	2,0	2,0	1,8	1,9	1,8	1,8	1,2	-	-	
<b>Maximum set pressure</b>	p [bar <sub>g</sub> ] S/G/L	16	16	16	16	16	16	16	16	16	16	16	-	-
<b>Max. set pressure</b> with special spring	p [bar <sub>g</sub> ] S/G/L	16	16	16	16	16	16	16	16	16	16	16	-	-
<b>Temperature<sup>2)</sup></b> acc. to DIN EN	min. [°C]	-10											-10	-
	max. [°C]	+150											+300	-

<b>Body material: 0.7043 (Ductile Gr. 60-40-18)</b>														
<b>DIN flange</b>	Inlet		<b>PN 40</b>										-	-
	Outlet		<b>PN 40</b>										-	-
<b>Minimum set pressure</b>	p [bar <sub>g</sub> ] S/G/L	0,3	0,3	0,2	0,2	0,2	0,2	0,2	0,2	0,2	0,2	0,2	-	-
<b>Min. set pressure<sup>1)</sup></b> Standard bellows	p [bar <sub>g</sub> ] S/G/L	3,0	3,0	3,0	3,0	3,0	3,0	3,0	3,0	3,0	3,0	3,0	-	-
<b>Min. set pressure</b> low pressure Bellow	p [bar <sub>g</sub> ] S/G/L	-	-	2,0	2,0	2,0	1,8	1,9	1,8	1,8	1,2	-	-	
<b>Maximum set pressure</b>	p [bar <sub>g</sub> ] S/G/L	16	16	16	16	16	16	16	16	16	16	16	-	-
<b>Max. set pressure</b> with special spring	p [bar <sub>g</sub> ] S/G/L	16	16	16	16	16	16	16	16	16	16	16	-	-
<b>Temperature<sup>2)</sup></b> acc. to DIN EN	min. [°C]	-45											-10	-
	max. [°C]	+150											+300	-

<sup>1)</sup> Min. set pressure of standard bellows = max. set pressure of bellows for low set pressure.

<sup>2)</sup> The temperature is limited by the soft seal material (see page 99/10). The values given here are valid for EPDM. Between -10°C and the lowest specified application temperature, proceed acc. to AD-Merkblatt W10.



## Pressure temperature ratings

Metric units														
	O-ring disc	Metal disc												
DN <sub>i</sub>	15	15	20	25	32	40	50	65	80	100	125	150		
DN <sub>o</sub>	15	15	20	25	32	40	50	65	80	100	125	150		
Actual orifice diameter d <sub>0</sub> [mm]	12	12	18	18	18	23	29	37	46	60	74	92		
Actual orifice area A <sub>0</sub> [mm <sup>2</sup> ]	113	113	254	254	254	416	661	1075	1662	2827	4301	6648		
<b>Body material: 1.0619 (WCB)</b>														
DIN flange	Inlet	PN 40												
	Outlet	PN 40												
Minimum set pressure	p [bar <sub>g</sub> ] S/G/L	0,3	0,3	0,2	0,2	0,2	0,2	0,2	0,2	0,2	0,2	0,2	0,2	
Min. set pressure <sup>1)</sup> Standard bellows	p [bar <sub>g</sub> ] S/G/L	3,0	3,0	3,0	3,0	3,0	3,0	3,0	3,0	3,0	3,0	3,0	3,0	
Min. set pressure low pressure Bellow	p [bar <sub>g</sub> ] S/G/L	–	–	2,0	2,0	2,0	1,8	1,9	1,8	1,8	1,2	1,2	on request	
Maximum set pressure	p [bar <sub>g</sub> ] S/G/L	40	40	40	40	40	40	40	35	35	30	32	16	
Max. set pressure with special spring	p [bar <sub>g</sub> ] S/G/L	40	40	40	40	40	40	40	40	35	30	32	16	
Temperature <sup>2)</sup> acc. to DIN EN	min. [°C]	-45	-85						–					–
	max. [°C]	+150	+450						–					–
<b>Body material: 1.4408 (CF8M)</b>														
DIN flange	Inlet	PN 40											–	–
	Outlet	PN 40											–	–
Minimum set pressure	p [bar <sub>g</sub> ] S/G/L	0,3	0,3	0,2	0,2	0,2	0,2	0,2	0,2	0,2	0,2	0,2	–	–
Min. set pressure <sup>1)</sup> Standard bellows	p [bar <sub>g</sub> ] S/G/L	3,0	3,0	3,0	3,0	3,0	3,0	3,0	3,0	3,0	3,0	3,0	–	–
Min. set pressure Bellows, low set pressure	p [bar <sub>g</sub> ] S/G/L	–	–	2,0	2,0	2,0	1,8	1,9	1,8	1,8	1,2	–	–	
Maximum set pressure	p [bar <sub>g</sub> ] S/G/L	40	40	40	40	40	40	31,6	20,2	25	22	–	–	
Max. set pressure with special spring	p [bar <sub>g</sub> ] S/G/L	40	40	40	40	40	40	40	26	25	22	–	–	
Temperature <sup>2)</sup> acc. to DIN EN	min. [°C]	-45	-270						–					–
	max. [°C]	+150	+400						–					–

<sup>1)</sup> Min. set pressure of standard bellows = max. set pressure of bellows for low set pressure.

<sup>2)</sup> The temperature is limited by the soft seal material (see page 99/10). The values given here are valid for EPDM. Between -10°C and the lowest specified application temperature, proceed acc. to AD-Merkblatt W10.

## Dimensions and weights

### Metric units

		O-ring disc	Metal disc										
	DN <sub>i</sub>	15	15	20	25	32	40	50	65	80	100	125	150
	DN <sub>o</sub>	15	15	20	25	32	40	50	65	80	100	125	150
	Actual orifice diameter d <sub>0</sub> [mm]	12	12	18	18	18	23	29	37	46	60	74	92
	Actual orifice area A <sub>0</sub> [mm <sup>2</sup> ]	113	113	254	254	254	416	661	1075	1662	2827	4301	6648
<b>Weight</b> [kg]		5	5	6	6	8	9	12	15	20	33	48	65
	with bellows	6,3	6,3	6,4	6,4	8,4	9,6	13	16	21,6	35,6	52,1	78,4
<b>Centre to face</b> [mm]	Inlet a	90	90	95	100	105	115	125	145	155	175	200	225
	Outlet b	90	90	95	100	105	115	125	145	155	175	200	225
<b>Height (H4)</b> [mm]	Standard H max.	310	310	315	320	325	335	360	475	530	605	745	870
	Bellows H max.	362	362	345	350	360	390	425	535	600	680	825	965
<b>Support brackets</b> [mm]	A												277
	B												160
(Drilled only on request, option code H42)	C												Ø 18
	D												278
	E												21

#### Body material: 0.6025 (cast iron)

<b>DIN flange<sup>1)</sup></b>	Inlet	PN 16	-	-
	Outlet	PN 16	-	-

#### Body material: 0.7043 (Ductile Gr. 60-40-18)

<b>DIN flange<sup>1)</sup></b>	Inlet	PN 40	-	-
	Outlet	PN 40	-	-

#### Body material: 1.0619 (WCB)

<b>DIN flange<sup>1)</sup></b>	Inlet	PN 40	-	-
	Outlet	PN 40	-	-

#### Body material: 1.4408 (CF8M)

<b>DIN flange<sup>1)</sup></b>	Inlet	PN 40	-	-
	Outlet	PN 40	-	-

<sup>1)</sup> Standard flange class For other flange drillings, refer to page 01/14 and 01/15.

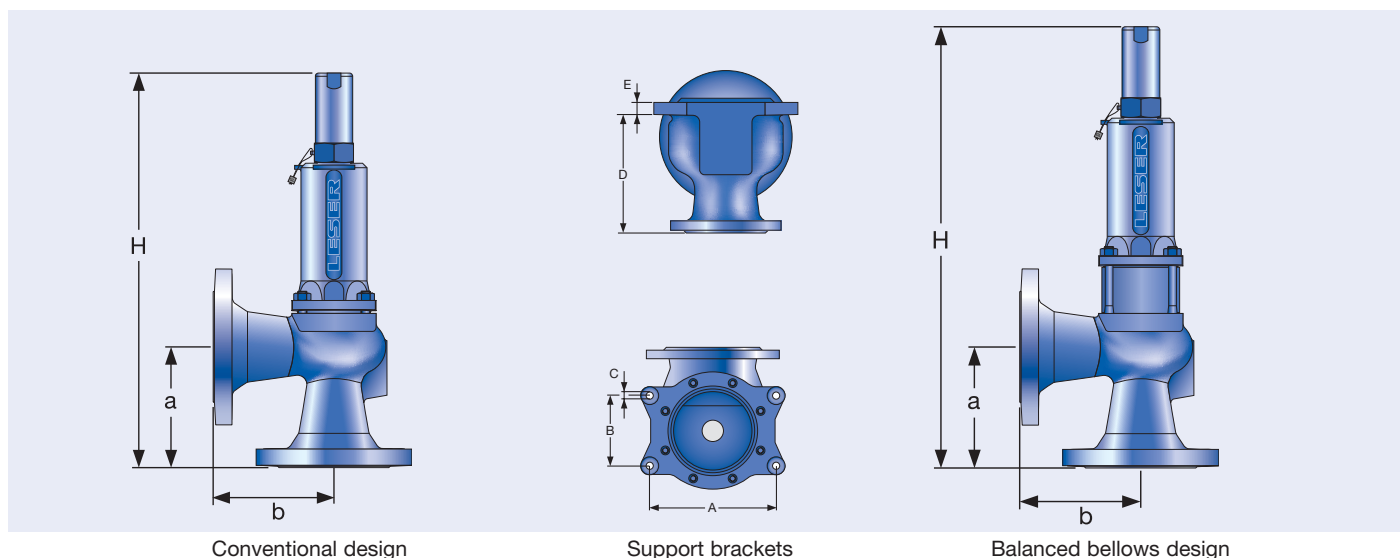

## Approvals

Approvals		O-ring disc	Metal disc		
	DN <sub>i</sub>	15	15	20	25 – 150
	DN <sub>o</sub>	15	15	20	25 – 150
	Actual orifice diameter d <sub>o</sub> [mm]	12	12	18	18 – 92
	Actual orifice area A <sub>o</sub> [mm <sup>2</sup> ]	113	113	254	254 – 6648
<b>Europe</b>		<b>Coefficient of discharge K<sub>dr</sub></b>			
DIN EN ISO 4126-1	Approval no.:	072020111Z0008/0/06			
	S/G	0,59	0,62	0,29	0,38
	L	0,47	0,48	0,19	0,25
<b>Germany</b>		<b>Coefficient of discharge α<sub>w</sub></b>			
AD 2000-Merkblatt A2 Standard safety valve	Approval no.:	TÜV SV 577			
	S/G	0,59	0,62	0,29	0,38
	L	0,47	0,48	0,19	0,25
<b>China</b>		<b>Coefficient of discharge K</b>			
AQSIQ	Approval no.:	TSF700301-2011			
	S/G	0,59	0,62	0,29	0,38
	L	0,47	0,48	0,19	0,25
<b>Russia</b>		<b>Coefficient of discharge K</b>			
GGTN/ GOSGORTECHNADZOR	Approval no.:	PPC 00-18458			
GOST R	Approval no.:	1989-06			
	S/G	0,59	0,62	0,29	0,38
	L	0,47	0,48	0,19	0,25
<b>Belarus</b>		<b>Coefficient of discharge α<sub>w</sub></b>			
	Approval no.:				
	S/G	0,7			
	L	0,45			
<b>Russia</b>		<b>Coefficient of discharge α<sub>w</sub></b>			
PROMATOMNADZOR	Approval no.:	15-171-2006			
	S/G	0,59	0,62	0,29	0,38
	L	0,47	0,48	0,19	0,25
<b>Classification societies</b>		<b>Homepage</b>			
Bureau Veritas	BV	www.bureauveritas.com		The valid approval no. changes with each renewal of the approval.  A certificate with the respective approval no. can be downloaded from the homepage of the classification society.	
Det Norske Veritas	DNV	www.dnv.com			
Germanischer Lloyd	GL	www.gl-group.com			
Lloyd's Register EMEA	LREMEA	www.lr.org			
Registro Italiano Navale	RINA	www.rina.org			

## Flange drillings

### Flange drillings

		O-ring disc	Metal disc											
	DN <sub>i</sub>	15	15	20	25	32	40	50	65	80	100	125	150	
	DN <sub>o</sub>	15	15	20	25	32	40	50	65	80	100	125	150	
	Valve size	1/2" x 1/2"	1/2" x 1/2"	3/4" x 3/4"	1" x 1"	1 1/4" x 1 1/4"	1 1/2" x 1 1/2"	2" x 2"	2 1/2" x 2 1/2"	3" x 3"	4" x 4"	5" x 5"	6" x 6"	
	Actual orifice diameter d <sub>0</sub> [mm]	12	12	18	18	18	23	29	37	46	60	74	92	
	Actual orifice area A <sub>0</sub> [mm <sup>2</sup> ]	113	113	254	254	254	416	661	1075	1662	2827	4301	6648	
<b>Body material: 0.6025 (cast iron)</b>														
Inlet	DIN EN 1092	PN 10	*	*	*	*	*	*	*	*	*	*	*	
		PN 16	*	*	*	*	*	*	*	*	*	*	*	
		PN 25	-	-	-	-	-	-	-	-	-	-	-	
		PN 40	-	-	-	-	-	-	-	-	-	-	-	
Outlet	DIN EN 1092	PN 10	*	*	*	*	*	*	*	*	*	*	*	
		PN 16	*	*	*	*	*	*	*	*	*	*	*	
<b>Body material: 0.7043 (Ductile Gr. 60-40-18), 1.0619 (WCB), 1.4408 (CF8M)</b>														
Inlet	DIN EN 1092	PN 10	*	*	*	*	*	*	*	H44	H44	H44	H44	
		PN 16	*	*	*	*	*	*	*	H45	H45	H45	H45	
		PN 25	*	*	*	*	*	*	*	*	*	*	*	
		PN 40	*	*	*	*	*	*	*	*	*	*	*	
	ASME B16.5	CL150	H64	H64	H64	H64	H64	H64	H64	H64	H64	[H64]	H64	
		CL300	[H65]	[H65]	-	H65	H65	-	[H65]	[H65]	-	-	-	
Outlet	DIN EN 1092	PN 10	*	*	*	*	*	*	*	H50	H50	H50	H50	
		PN 16	*	*	*	*	*	*	*	H51	H51	H51	H51	
	ASME B16.5	CL150	H79	H79	H79	H79	H79	H79	H79	H79	H79	[H79]	H79	
		CL300	H80	H80	-	H80	H80	-	[H80]	[H80]	-	-	-	

For an explanation of the characters and symbols, refer to page 00/07.  
 Note: Flange drillings and facings always meet the requirements of the given flange standards.  
 Flange thickness and outside diameter may deviate from the standard.

## Flange facings

Flange facings										
Information	Standard	Inlet	Outlet		Remark					
<b>General</b>										
Flange, undrilled	–	H38	H39							
Linde-V-Nut, Form V48	Linde Standard 420-08	J07	J08		Groove: Rz 16					
Linde-V-Nut, Form V48A	LWN 313.36	J05	J06		Groove: Rz 4, e.g. for hydrogen					
Lens-shape seal form L (without lens-shape seal)	DIN 2696 LWN 313.35	J11	J12							
<b>According to DIN EN</b>										
<b>Flange facings</b>										
<b>DIN EN 1092 (new)</b>		<b>DIN 2526 (old)</b>	<b>Inlet</b>		<b>Outlet</b>		<b>Remark</b>			
(also see LWN 313.40)			PN 10 – PN 40	PN 40	PN 10 – PN 40	PN 40	Rz specification acc. to DIN EN 1092 in µm			
Sealing strip	Form B1	Form C	*	–	*	–	Seal. strip.: Rz = 12,5 – 50			
	Form B2	Form D	L36	*	L38	*	Seal. strip.: Rz = 3,2 – 12,5			
Tongue, Form C <sup>1)</sup>		Tongue, Form F	H94	H94	H92	H92	only for steel flange			
Groove, Form D <sup>1)</sup>		Groove, Form N	H93	H93	H91	H91				
Male, Form E		Male, Form V13	H96	H96	H98	H98				
Female, Form F		Female, Form R13	H97	H97	H99	H99				
O-ring Male, Form G		Male, Form V14	J01	J01	J02	J02				
O-ring Female, Form H		Female, Form R14	J03	J03	J04	J04				
<b>According to ASME B16.5</b>										
Body material	Inlet	Outlet	Smooth Finish <sup>2)</sup>		Serrated Finish		RTJ-Groove			
			Inlet	Outlet	Inlet	Outlet	Inlet		Outlet	
			Option code	Option code	Pressure level	Option code	Pressure level	Option code		
0.7043	All	All	L52	L53	*	*	–	–	–	–
1.0619, 1.4408	All	All	L52	L53	*	*	CL150	H62	CL150	H63

<sup>1)</sup> Groove depths or alternatively tongue heights have increased acc. to DIN EN 1092 compared to the former DIN construction (see LWN 313.40).  
By default, LESER uses milling to produce the groove for flange valves. If a customer requests a turned surface in soil of the groove acc. to DIN 2512 or DIN EN 1092-1, then "S01: bottom of the groove drilled" must be specified.

<sup>2)</sup> Smooth Finish is not defined in the effective standards. LESER's definition for Smooth Finish can be found on page 00/07.

For an explanation of signs and symbols, refer to page 00/07.  
Note: Flange drillings and facings always meet the requirements of mentioned flange standards.  
Flange thickness and outer diameter may deviate from flange standard.

## Capacities – steam

Calculation of the capacity for saturated steam acc. to AD 2000 Merkblatt A2 with 10% overpressure.  
Capacities at 1 bar and lower are calculated at 0,1 bar overpressure.

Metric units		AD 2000-Merkblatt A2 [kg/h]											
	O-ring disc	Metal disc											
DN <sub>i</sub>	15	15	20	25	32	40	50	65	80	100	125	150	
DN <sub>o</sub>	15	15	20	25	32	40	50	65	80	100	125	150	
Actual orifice diameter d <sub>o</sub> [mm]	12	12	18	18	18	23	29	37	46	60	74	92	
Actual orifice area A <sub>o</sub> [mm <sup>2</sup> ]	113	113	254	254	254	416	661	1075	1662	2827	4301	6648	
LEO <sub>s/g</sub> <sup>*)</sup> [inch <sup>2</sup> ]	0,111	0,111	0,117	0,154	0,154	0,251	0,399	0,650	1,004	1,708	2,598	4,016	
Set pressure [bar]	Capacity [kg/h]												
0,2				34	34	55	88	142	220	375	570	880	
0,5	55	53	30	63	63	102	163	265	410	697	1060	1638	
1	78	78	67	101	101	165	263	428	661	1125	1711	2645	
2	125	125	129	170	170	278	442	720	1113	1893	2880	4452	
3	168	168	177	232	232	379	603	981	1517	2581	3926	6068	
4	200	210	221	290	290	473	752	1224	1892	3218	4895	7567	
5		251	265	347	347	566	900	1465	2265	3853	5861	9058	
6		293	308	404	404	659	1048	1706	2636	4485	6823	10545	
7		333	350	459	459	750	1192	1940	2999	5102	7761	11996	
8		374	394	516	516	842	1339	2179	3368	5730	8717	13473	
9		415	437	572	572	934	1485	2418	3737	6358	9671	14948	
10		456	480	629	629	1026	1632	2656	4105	6984	10624	16421	
12		538	566	741	741	1210	1924	3132	4842	8237	12530	19366	
14		618	650	852	852	1391	2211	3599	5563	9464	14395	22250	
16		699	736	964	964	1574	2503	4074	6297	10714	16296	25189	
18		781	822	1077	1077	1758	2795	4550	7033	11965	18200	28131	
20		863	908	1190	1190	1942	3088	5027	7770	13218	20107		
22		942	991	1299	1299	2121	3372	5489	8484	14434	21956		
24		1024	1078	1412	1412	2306	3665	5967	9222	15690	23866		
26		1106	1164	1525	1525	2491	3959	6445	9962	16949			
28		1189	1251	1639	1639	2676	4254	6925	10704	18211			
30		1271	1338	1753	1753	2862	4550	7407	11449	19478			
32		1354	1425	1867	1867	3049	4847	7890	12195	20748			
34													
36													
38													
40													

\*) LEO<sub>s/g</sub> = LESER Effective Orifice steam/gases please refer to page 00/11  
"How to use" capacity tables, refer to page 00/09

## Capacity table – air

Calculation of the capacity for air acc. to AD 2000 Merkblatt A2 with 10% overpressure.

Capacities at 1 bar and lower are calculated at 0,1 bar overpressure.

### Metric units

### AD 2000 Merkblatt A2 [ $m_n^3/h$ ]

	O-ring disc	Metal disc											
DN <sub>i</sub>	15	15	20	25	32	40	50	65	80	100	125	150	
DN <sub>o</sub>	15	15	20	25	32	40	50	65	80	100	125	150	
Actual orifice diameter d <sub>0</sub> [mm]	12	12	18	18	18	23	29	37	46	60	74	92	
Actual orifice area A <sub>0</sub> [mm <sup>2</sup> ]	113	113	254	254	254	416	661	1075	1662	2827	4301	6648	
LEO <sub>SG</sub> <sup>*)</sup> [inch <sup>2</sup> ]	0,111	0,111	0,117	0,154	0,154	0,251	0,399	0,650	1,004	1,708	2,598	4,016	
Set pressure [bar]	Capacity [ $m_n^3/h$ ]												
0,2				39	39	63	101	165	255	431	660	1019	
0,5	64	62	35	74	74	120	191	311	481	819	1245	1925	
1	93	93	80	121	121	197	313	510	788	1341	2039	3152	
2	151	151	156	206	206	336	534	870	1344	2287	3478	5377	
3	206	206	217	284	284	463	737	1199	1854	3153	4797	7414	
4	246	258	272	356	356	582	925	1505	2327	3958	6021	9306	
5	296	311	327	429	429	700	1113	1811	2800	4763	7245	11198	
6	346	363	382	501	501	818	1301	2117	3273	5568	8469	13091	
7	396	416	438	574	574	936	1489	2423	3746	6373	9694	14983	
8	446	468	493	646	646	1055	1677	2729	4219	7177	10918	16875	
9	496	521	548	718	718	1173	1865	3035	4692	7982	12142	18767	
10	546	573	604	791	791	1291	2053	3342	5165	8787	13366	20659	
12	646	679	714	936	936	1528	2429	3954	6111	10397	15815	24444	
14	746	784	825	1081	1081	1764	2805	4566	7057	12006	18263	28228	
16	846	889	935	1225	1225	2001	3181	5178	8003	13616	20711	32013	
18	946	994	1046	1370	1370	2237	3557	5790	8949	15226	23160		
20	1046	1099	1156	1515	1515	2474	3933	6402	9895	16835	25608		
22	1146	1204	1267	1660	1660	2710	4309	7014	10842	18445	28057		
24	1245	1309	1377	1805	1805	2947	4685	7626	11788	20055	30505		
26	1345	1414	1488	1950	1950	3183	5061	8238	12734	21664	32954		
28	1445	1519	1599	2095	2095	3420	5437	8851	13680	23274	35402		
30	1545	1624	1709	2240	2240	3656	5813	9463	14626	24883	37850		
32	1645	1729	1820	2384	2384	3893	6189	10075	15572		40299		
34	1745	1834	1930	2529	2529	4130	6565	10687	16518				
36	1845	1939	2041	2674	2674	4366	6941	11299					
38	1945	2044	2151	2819	2819	4603	7317	11911					
40	2045	2149	2262	2964	2964	4839	7693	12523					

<sup>\*)</sup> LEO<sub>SG</sub> = LESER Effective Orifice steam/gases please refer to page 00/11

"How to use" capacity tables, refer to page 00/09

## Capacity table – water

Calculation of the capacity for water acc. to AD 2000 Merkblatt A2 with 10% overpressure at 20 °C.  
Capacities at 1 bar and lower are calculated at 0,1 bar overpressure.

Metric units		AD 2000-Merkblatt A2 [ $10^3\text{kg/h}$ ]											
		O-ring disc	Metal disc										
DN <sub>i</sub>	15	15	20	25	32	40	50	65	80	100	125	150	
DN <sub>o</sub>	15	15	20	25	32	40	50	65	80	100	125	150	
Actual orifice diameter d <sub>0</sub> [mm]	12	12	18	18	18	23	29	37	46	60	74	92	
Actual orifice area A <sub>0</sub> [mm <sup>2</sup> ]	113	113	254	254	254	416	661	1075	1662	2827	4301	6648	
LEO <sub>L</sub> *) [inch <sup>2</sup> ]	0,111	0,111	0,117	0,154	0,154	0,251	0,399	0,650	1,004	1,708	2,598	4,016	
Set pressure [bar]	Capacity [ $10^3\text{kg/h}$ ]												
0,2				1,77	1,77	2,89	4,60	7,50	11,6	19,7	30,0	46,3	
0,5	2,09	2,14	1,90	2,51	2,51	4,09	6,51	10,6	16,4	27,8	42,4	65,5	
1	2,84	2,90	2,58	3,39	3,39	5,54	8,81	14,3	22,2	37,7	57,4	88,7	
2	4,01	4,10	3,65	4,80	4,80	7,84	12,5	20,3	31,3	53,3	81,1	125	
3	4,91	5,02	4,47	5,88	5,88	9,60	15,3	24,8	38,4	65,3	99,3	154	
4	5,67	5,79	5,16	6,79	6,79	11,1	17,6	28,7	44,3	75,4	115	177	
5	6,34	6,48	5,77	7,59	7,59	12,4	19,7	32,1	49,6	84,3	128	198	
6	6,95	7,09	6,32	8,31	8,31	13,6	21,6	35,1	54,3	92,4	140	217	
7	7,50	7,66	6,82	8,98	8,98	14,7	23,3	37,9	58,6	99,8	152	235	
8	8,02	8,19	7,30	9,60	9,60	15,7	24,9	40,6	62,7	107	162	251	
9	8,51	8,69	7,74	10,2	10,2	16,6	26,4	43,0	66,5	113	172	266	
10	8,97	9,16	8,16	10,7	10,7	17,5	27,9	45,3	70,1	119	181	280	
12	9,82	10,0	8,93	11,8	11,8	19,2	30,5	49,7	76,8	131	199	307	
14	10,6	10,8	9,65	12,7	12,7	20,7	33,0	53,7	82,9	141	215	332	
16	11,3	11,6	10,3	13,6	13,6	22,2	35,2	57,4	88,7	151	229	355	
18	12,0	12,3	10,9	14,4	14,4	23,5	37,4	60,8	94,0	160	243		
20	12,7	13,0	11,5	15,2	15,2	24,8	39,4	64,1	99,1	169	257		
22	13,3	13,6	12,1	15,9	15,9	26,0	41,3	67,3	104	177	269		
24	13,9	14,2	12,6	16,6	16,6	27,1	43,2	70,2	109	185	281		
26	14,5	14,8	13,2	17,3	17,3	28,3	44,9	73,1	113	192	292		
28	15,0	15,3	13,6	18,0	18,0	29,3	46,6	75,9	117	200	304		
30	15,5	15,9	14,1	18,6	18,6	30,3	48,2	78,5	121	207	314		
32	16,0	16,4	14,6	19,2	19,2	31,3	49,8	81,1	125		324		
34	16,5	16,9	15,0	19,8	19,8	32,3	51,4	83,6	129				
36	17,0	17,4	15,5	20,4	20,4	33,2	52,9	86,0					
38	17,5	17,9	15,9	20,9	20,9	34,2	54,3	88,4					
40	17,9	18,3	16,3	21,5	21,5	35,0	55,7	90,7					

\*) LEO<sub>L</sub> = LESER Effective Orifice liquids, please refer to page 00/11  
"How to use" capacity tables, refer to page 00/09



## Available options

For more information, also see  
"Accessories and Options" as of page 99/01.

### Heating jacket

H29, H30: Coupling G 3/8, G 3/4  
H31, H32: Flange DN15, DN25

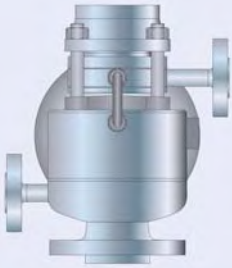

### Drain hole

J18: G 1/4  
J19: G 1/2

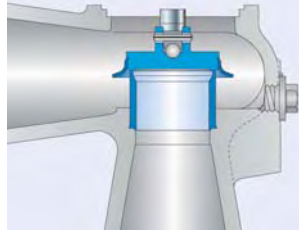

### Open bonnet

See art. no.

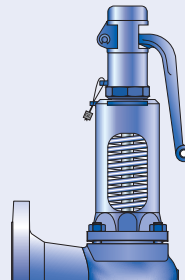

### O-ring disc

J20: FFKM "C"  
J21: CR "K"  
J22: EPDM "D"  
J23: FKM "L"

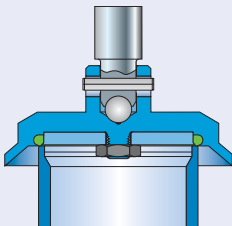

### Disc with sealing plate

J68: Open bonnet  
J78: Closed bonnet

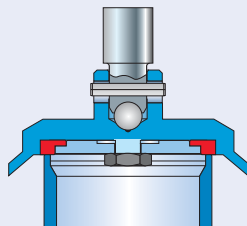

### Balanced bellows

J68: Open bonnet  
J78: Closed bonnet

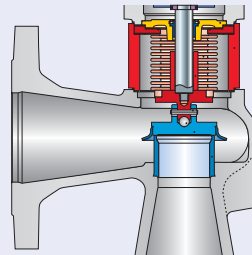

### Conversion kit for balanced bellows

art. no., see page 01/14

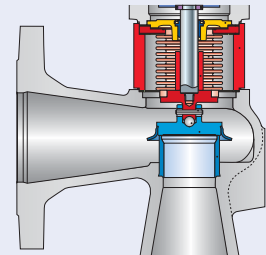

### Screwed cap H2

H2

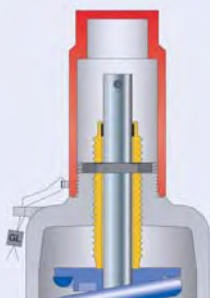

### Plain lever H3

H3

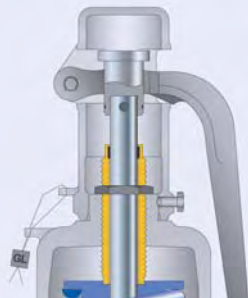

### Packed lever H4

H4

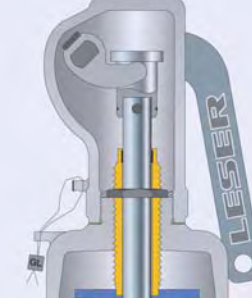

### O-ring damper H2

J65

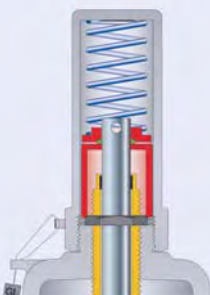

### O-ring damper H4

J66

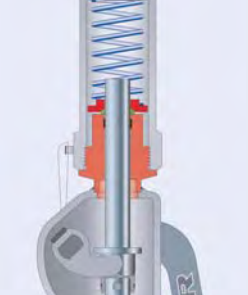

### Lift indicator

J39: Adaptor H4  
J93: Lift indicator

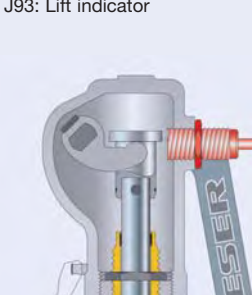

### Test gag

J69: H4  
J70: H4

