

# SIEMENS

## SITRANS F

### Electromagnetic flowmeters SITRANS FMS500

#### Operating Instructions



<u>Introduction</u>	<b>1</b>
<u>Safety notes</u>	<b>2</b>
<u>Description</u>	<b>3</b>
<u>Installing/Mounting</u>	<b>4</b>
<u>Connecting</u>	<b>5</b>
<u>Service and maintenance</u>	<b>6</b>
<u>Diagnostics and Troubleshooting</u>	<b>7</b>
<u>Technical specifications</u>	<b>8</b>
<u>Product documentation and support</u>	<b>A</b>
<u>Appendix</u>	<b>B</b>

7ME653 (SITRANS FMS500 with FMT020)

## Legal information

### Warning notice system

This manual contains notices you have to observe in order to ensure your personal safety, as well as to prevent damage to property. The notices referring to your personal safety are highlighted in the manual by a safety alert symbol, notices referring only to property damage have no safety alert symbol. These notices shown below are graded according to the degree of danger.

 <b>DANGER</b>
indicates that death or severe personal injury <b>will</b> result if proper precautions are not taken.
 <b>WARNING</b>
indicates that death or severe personal injury <b>may</b> result if proper precautions are not taken.
 <b>CAUTION</b>
indicates that minor personal injury can result if proper precautions are not taken.
<b>NOTICE</b>
indicates that property damage can result if proper precautions are not taken.

If more than one degree of danger is present, the warning notice representing the highest degree of danger will be used. A notice warning of injury to persons with a safety alert symbol may also include a warning relating to property damage.

### Qualified Personnel

The product/system described in this documentation may be operated only by **personnel qualified** for the specific task in accordance with the relevant documentation, in particular its warning notices and safety instructions. Qualified personnel are those who, based on their training and experience, are capable of identifying risks and avoiding potential hazards when working with these products/systems.

### Proper use of Siemens products

Note the following:

 <b>WARNING</b>
Siemens products may only be used for the applications described in the catalog and in the relevant technical documentation. If products and components from other manufacturers are used, these must be recommended or approved by Siemens. Proper transport, storage, installation, assembly, commissioning, operation and maintenance are required to ensure that the products operate safely and without any problems. The permissible ambient conditions must be complied with. The information in the relevant documentation must be observed.

### Trademarks

All names identified by ® are registered trademarks of Siemens Aktiengesellschaft. The remaining trademarks in this publication may be trademarks whose use by third parties for their own purposes could violate the rights of the owner.

### Disclaimer of Liability

We have reviewed the contents of this publication to ensure consistency with the hardware and software described. Since variance cannot be precluded entirely, we cannot guarantee full consistency. However, the information in this publication is reviewed regularly and any necessary corrections are included in subsequent editions.

# Table of contents

<b>1</b>	<b>Introduction</b> .....	<b>5</b>
1.1	Purpose of this documentation .....	5
1.2	Document history .....	5
1.3	Designated use .....	5
1.4	Checking the consignment.....	5
1.5	Items supplied .....	6
1.6	Industrial use note .....	6
1.7	Cybersecurity information.....	6
1.8	Transportation and storage .....	7
1.9	Notes on warranty .....	7
<b>2</b>	<b>Safety notes</b> .....	<b>9</b>
2.1	Laws and directives .....	9
2.2	Conformity with European directives .....	10
2.3	Conformity with PED directive and PESR regulation.....	10
2.4	Improper device modifications.....	12
<b>3</b>	<b>Description</b> .....	<b>13</b>
3.1	System components.....	13
3.2	Design .....	14
3.3	Theory of operation .....	14
<b>4</b>	<b>Installing/Mounting</b> .....	<b>17</b>
4.1	Introduction.....	17
4.2	Installation safety precautions.....	17
4.3	Determining a location.....	18
4.4	Inlet and outlet conditions .....	19
4.5	Orienting the sensor .....	20
4.6	Mounting .....	22
4.7	Torques values .....	23
4.8	Potential equalization.....	25
<b>5</b>	<b>Connecting</b> .....	<b>27</b>
5.1	General information.....	27
5.2	Connecting the sensor .....	28

5.3	Electrical connection.....	32
5.4	Installation check.....	36
5.5	Potting.....	37
5.6	Direct burial.....	38
<b>6</b>	<b>Service and maintenance.....</b>	<b>39</b>
6.1	Maintenance.....	39
6.2	Technical support.....	39
6.3	Transportation and storage.....	40
6.4	Return procedure.....	41
6.5	Disposal.....	41
<b>7</b>	<b>Diagnostics and Troubleshooting.....</b>	<b>43</b>
7.1	Sensor check.....	43
7.2	Fluctuating process values.....	44
<b>8</b>	<b>Technical specifications.....</b>	<b>45</b>
8.1	FMS500.....	45
8.2	Cable data.....	48
8.3	Effect of temperature on working pressure.....	49
8.4	Process fluid conductivity.....	50
8.5	Liner selection.....	51
8.6	Electrode selection.....	51
8.7	Sizing tables.....	52
8.8	Dimensions and weight.....	54
<b>A</b>	<b>Product documentation and support.....</b>	<b>59</b>
A.1	Product documentation.....	59
A.2	Technical support.....	60
<b>B</b>	<b>Appendix.....</b>	<b>61</b>
B.1	Flange mating dimensions (metric).....	61
B.2	Coil resistance.....	64
	<b>Glossary.....</b>	<b>65</b>
	<b>Index.....</b>	<b>67</b>

# Introduction

## 1.1 Purpose of this documentation

These instructions contain all information required to commission and use the device. Read the instructions carefully prior to installation and commissioning. In order to use the device correctly, first review its principle of operation.

The instructions are aimed at persons mechanically installing, connecting and commissioning the device, as well as service and maintenance engineers.

## 1.2 Document history

The contents of these instructions are regularly reviewed and corrections are included in subsequent editions. We welcome all suggestions for improvement.

The following table shows the most important changes in the documentation compared to each previous edition.

Edition	Remarks
01/2024	First edition

## 1.3 Designated use

Use the device in accordance with the information on the nameplate and in the Technical specifications (Page 45).

## 1.4 Checking the consignment

1. Check the packaging and the delivered items for visible damages.
2. Report any claims for damages immediately to the shipping company.
3. Retain damaged parts for clarification.
4. Check the scope of delivery by comparing your order to the shipping documents for correctness and completeness.

	<b>WARNING</b>
<b>Using a damaged or incomplete device</b>	
Risk of explosion in hazardous areas.	
<ul style="list-style-type: none"> <li>• Do not use damaged or incomplete devices.</li> </ul>	

## 1.5 Items supplied

- SITRANS FMS500
- Calibration report
- DVD with documentation and certificates
- Safety Note

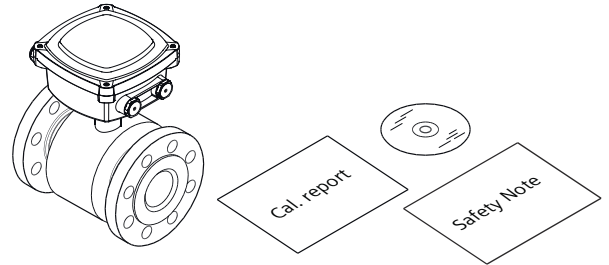

## 1.6 Industrial use note

<b>NOTICE</b>
<b>Use in a domestic environment</b>
This Class A Group 1 equipment is intended for use in industrial areas. In a domestic environment this device may cause radio interference.

## 1.7 Cybersecurity information

Siemens provides products and solutions with industrial cybersecurity functions that support the secure operation of plants, systems, machines and networks.

In order to protect plants, systems, machines and networks against cyber threats, it is necessary to implement – and continuously maintain – a holistic, state-of-the-art industrial cybersecurity concept. Siemens' products and solutions constitute one element of such a concept.

Customers are responsible for preventing unauthorized access to their plants, systems, machines and networks. Such systems, machines and components should only be connected to an enterprise network or the internet if and to the extent such a connection is necessary and only when appropriate security measures (e.g. firewalls and/or network segmentation) are in place.

For additional information on industrial cybersecurity measures that may be implemented, please visit <https://www.siemens.com/cybersecurity-industry>.

Siemens' products and solutions undergo continuous development to make them more secure. Siemens strongly recommends that product updates are applied as soon as they are available and that the latest product versions are used. Use of product versions that are no longer supported, and failure to apply the latest updates may increase customer's exposure to cyber threats.

To stay informed about product updates, subscribe to the Siemens Industrial Cybersecurity RSS Feed under <https://new.siemens.com/cert>.

## 1.8 Transportation and storage

To guarantee sufficient protection during transport and storage, observe the following:

- Keep the original packaging for subsequent transportation.
- Devices/replacement parts should be returned in their original packaging.
- If the original packaging is no longer available, ensure that all shipments are properly packaged to provide sufficient protection during transport. Siemens cannot assume liability for any costs associated with transportation damages.

<b>NOTICE</b>
<b>Insufficient protection during storage</b>
The packaging only provides limited protection against moisture and infiltration.
<ul style="list-style-type: none"><li>• Provide additional packaging as necessary.</li></ul>



Special conditions for storage and transportation of the device are listed in Technical specifications (Page 45).

## 1.9 Notes on warranty

The contents of this manual shall not become part of or modify any prior or existing agreement, commitment or legal relationship. The sales contract contains all obligations on the part of Siemens as well as the complete and solely applicable warranty conditions. Any statements regarding device versions described in the manual do not create new warranties or modify the existing warranty.

The content reflects the technical status at the time of publishing. Siemens reserves the right to make technical changes in the course of further development.





## Safety notes

This device left the factory in good working condition. In order to maintain this status and to ensure safe operation of the device, observe these instructions and all the specifications relevant to safety.

Observe the information and symbols on the device. Do not remove any information or symbols from the device. Always keep the information and symbols in a completely legible state.



### CAUTION

**Correct, reliable operation of the product requires proper transport, storage, positioning and assembly as well as careful operation and maintenance.**

Only qualified personnel should install or operate this instrument.

### Note

Alterations to the product, including opening or improper modifications of the product are not permitted.

If this requirement is not observed, the CE mark and the manufacturer's warranty will expire.

If the equipment is used in a manner not specified by the manufacturer, the protection provided by the equipment may be impaired.

## 2.1 Laws and directives

Observe the safety rules, provisions and laws applicable in your country during connection, assembly and operation. These include, for example:

- National Electrical Code (NEC - NFPA 70) (USA)
- Canadian Electrical Code (CEC Part I) (Canada)

Further provisions for hazardous area applications are for example:

- IEC 60079-14 (international)
- EN 60079-14 (EU and UK)

## 2.2 Conformity with European directives

The product described in this document is in conformity with the relevant harmonization legislation, and its amendments, of the European Union.

Electromagnetic compatibility EMC 2014/30/EU	Directive of the European Parliament and of the Council on the harmonisation of the laws of the Member States relating to electromagnetic compatibility
Low voltage directive LVD 2014/35/EU	Directive of the European Parliament and of the Council on the harmonisation of the laws of the Member States relating to the making available on the market of electrical equipment designed for use within certain voltage limits
Pressure equipment directive PED 2014/68/EU	Directive of the European Parliament and of the Council on the harmonisation of the laws of the Member States relating to the making available on the market of pressure equipment
Restriction of hazardous substances directive RoHS 2011/65/EU	Directive of the European Parliament and the Council on the restriction of the use of certain hazardous substances in electrical and electronic equipment

The applicable directives can be found in the EU Declaration of Conformity of the specific device.

## 2.3 Conformity with PED directive and PESR regulation

### Instrument safety standards

The device has been tested at the factory, based on the safety requirements. In order to maintain this condition over the expected life of the device the requirements described in these Operating Instructions must be observed.

<b>NOTICE</b>
<b>Material compatibility</b> Siemens Flow Instruments can provide assistance with the selection of wetted sensor parts. However, the full responsibility for the selection rests with the customer and Siemens Flow Instruments can take no responsibility for any failure due to material incompatibility.

### Conformity with PED directive

"Pressure Equipment Directive" (PED) is mandatory for all pressure equipment sold within the EU and EFTA.

---

#### Note

#### Liquids danger group

The device is designed for liquids of danger group "Liquids fluid group 1"

---

## 2.3 Conformity with PED directive and PESR regulation

Siemens Flow Instruments products confirm to PED by following the tables below.

Table 2-1 PED Compliance for fluids under 100 °C (PED classification: liquids) EN 1092, ANSI B16.5, AWWA C207, AS4087 and JIS2220 flanges

Flange mm	EN 1092				ANSI B16.5	AWWA C207	AS4087	JIS B 2220
	PN 6	PN 10	PN 16	PN 40	Class 150	Class D	class16 (AS16)	K 10
15	N/A	N/A	N/A	SEP	SEP	N/A	N/A	SEP
25	N/A	N/A	N/A	SEP	SEP	N/A	N/A	SEP
40	N/A	N/A	N/A	SEP	SEP	N/A	N/A	SEP
50	N/A	N/A	SEP	N/A	SEP	N/A	SEP	SEP
65	N/A	N/A	SEP	N/A	SEP	N/A	SEP	SEP
80	N/A	N/A	SEP	N/A	SEP	N/A	SEP	SEP
100	N/A	N/A	SEP	N/A	SEP	N/A	SEP	SEP
125	N/A	N/A	SEP	N/A	PED (II)	N/A	N/A	SEP
150	N/A	N/A	PED (II)	N/A	PED (II)	N/A	SEP	PED (II)
200	N/A	SEP	PED (II)	N/A	PED (II)	N/A	SEP	PED (II)
250	N/A	PED (I)	PED (II)	N/A	PED (II)	N/A	SEP	PED (II)
300	N/A	PED (I)	PED (II)	N/A	PED (II)	N/A	SEP	PED (II)
350	N/A	PED (I)	PED (II)	N/A	PED (II)	N/A	PED (I)	PED (II)
400	N/A	PED (I)	PED (II)	N/A	PED (II)	N/A	PED (I)	PED (II)
450	N/A	PED (I)	PED (II)	N/A	PED (II)	N/A	PED (I)	PED (II)
500	N/A	PED (I)	PED (II)	N/A	PED (II)	N/A	PED (I)	PED (II)
600	N/A	PED (I)	PED (II)	N/A	PED (II)	N/A	PED (I)	PED (II)
700	N/A	PED (I)	PED (II)	N/A	N/A	PED (I)	PED (I)	N/A
750	N/A	N/A	N/A	N/A	N/A	PED (I)	N/A	N/A
800	N/A	PED (I)	PED (II)	N/A	N/A	PED (I)	PED (I)	N/A
900	N/A	PED (I)	PED (II)	N/A	N/A	PED (I)	PED (I)	N/A
1000	N/A	PED (I)	PED (II)	N/A	N/A	PED (I)	PED (I)	N/A
1050	N/A	N/A	N/A	N/A	N/A	PED (I)	N/A	N/A
1100	N/A	N/A	N/A	N/A	N/A	PED (I)	N/A	N/A
1200	N/A	PED (I)	PED (II)	N/A	N/A	PED (I)	PED (I)	N/A

The key to the tables is as follows:

Table 2-2 Table key

SEP	Product covered by PED under category SEP (Sound Engineering Practice)
PED	Product covered by PED under category I to III as fully PED-conforming
N/A	Size/pressure not available in the size range

## 2.4 Improper device modifications

 **WARNING**

**Improper device modifications**

Risk to personnel, system, and environment can result from modifications to the device, particularly in hazardous areas.

- Only carry out modifications that are described in the instructions for the device. Failure to observe this requirement cancels the manufacturer's warranty and the product approvals. Do not operate the device after unauthorized modifications.

## Description

The main applications of the SITRANS FM electromagnetic flow sensors can be found in the following fields:

- Process industry
- Chemical industry
- Steel industry
- Mining
- Utility
- Power generation & distribution
- Oil & gas / HPI
- Water & waste water
- Pulp & paper

### 3.1 System components

The SITRANS FMS500 sensor is compatible with:

- Transmitter (type: SITRANS FMT020)

### 3.2 Design

The SITRANS FMS500 is an electromagnetic flow sensor designed to meet the requirements in ground water, drinking water, waste water, sewage or sludge applications. With its coned design, increased low-flow accuracy is achieved making it especially useful for leak detection. It is suitable for direct burial and constant flooding. FMS500 complies with drinking water approvals.



FMS500 compact version with FMT020 transmitter FMS500 remote version (FM520)

The sensors carry a wide range of approvals, see Technical specifications (Page 45).

### 3.3 Theory of operation

The flow measuring principle is based on Faraday's law of electromagnetic induction.

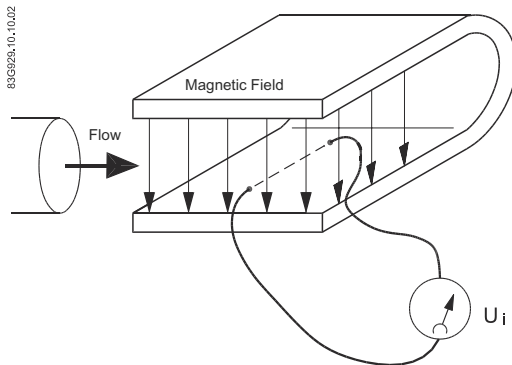

$U_i$  = When an electrical conductor of length  $L$  is moved at velocity  $v$ , perpendicular to the lines of flux through a magnetic field of strength  $B$ , the voltage  $U_i$  is induced at the ends of the conductor

$$U_i = L \times B \times v$$

- $U_i$  = Induced voltage
- $L$  = Conductor length = Inner pipe diameter =  $k_1$
- $B$  = Magnetic field strength =  $k_2$

- $v$  = Velocity of conductor (media)
- $k = k_1 \times k_2$

**$U_i = k \times v$ , the electrode signal is directly proportional to the fluid velocity**

### Operating principle

The transmitter generates a pulsating magnetizing current that drives the coils in the sensor. The current is permanently monitored and corrected. Errors or cable faults are registered by the self-monitoring circuit.

The input circuit amplifies the flow-proportional induced voltage signal from the electrodes. The input impedance is extremely high:  $>10^{14} \Omega$  which allows flow measurements on fluids with conductivities as low as  $5 \mu\text{S}/\text{cm}$ . Measuring errors due to cable capacitance are eliminated due to active cable screening.

*3.3 Theory of operation*



# Installing/Mounting

## 4.1 Introduction

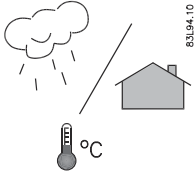

SITRANS F flowmeters are suitable for indoor and outdoor installations.

- Make sure that pressure and temperature specifications indicated on the device nameplate / label will not be exceeded.

## 4.2 Installation safety precautions

<p><b>⚠ WARNING</b></p> <p><b>High pressure hazard</b></p> <p>In applications with working pressures/media that can be dangerous to people, surroundings, equipment or others in case of pipe fracture, we recommend that special precautions such as special placement, shielding or installation of a pressure guard or a safety valve are taken when the flowmeter is mounted.</p>
---

### Note

Install the sensor in well-supported pipelines in order to support the weight of the flowmeter.

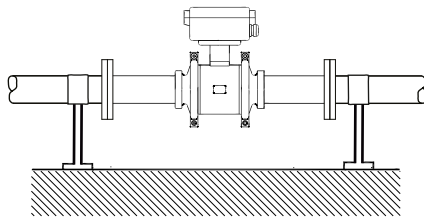

### Vibrations

Avoid strong vibrations.

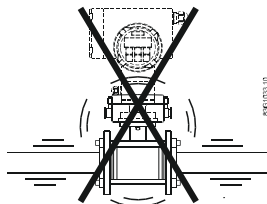



Figure 4-1 Avoid vibrations

 <b>CAUTION</b>
In applications with strong vibrations, Siemens recommends remote mounting of the transmitter!

## 4.3 Determining a location

### Note

The sensor must always be completely filled with liquid.

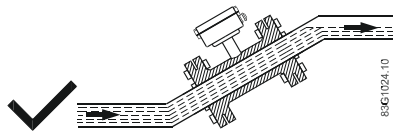

Figure 4-2 Correct installation with filled pipes

- Avoid the following installations
  - Installation at the highest point in the pipe system
  - Installation in vertical pipes with free outlet

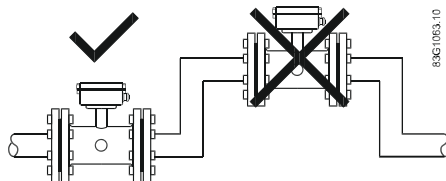

Figure 4-3 Wrong installation at high point

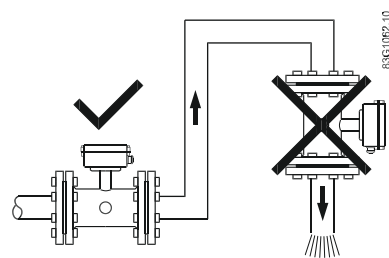

Figure 4-4 Correct installation at low point before outlet

## 4.4 Inlet and outlet conditions

### Inlet and outlet conditions

To achieve accurate flow measurement it is essential to have straight lengths of inlet and outlet pipes and a certain distance to pumps and valves.

It is also important to centre the flowmeter in relation to pipe flanges and gaskets.

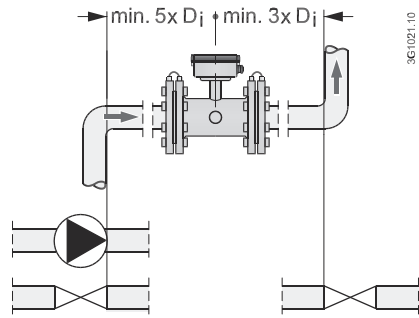
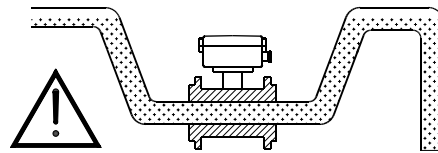

Figure 4-5 Inlet and outlet conditions

### Installation in partially filled pipes

For partially filled pipes or pipes with downward flow and free outlet the flowmeter should be located in a U-tube.



### Installation in large pipes

The flowmeter can be installed between two reducers (for example DIN 28545). At  $\alpha \leq 8^\circ$  the following pressure drop curves apply. The curves are applicable to water.

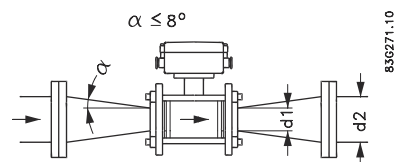

4.5 Orienting the sensor

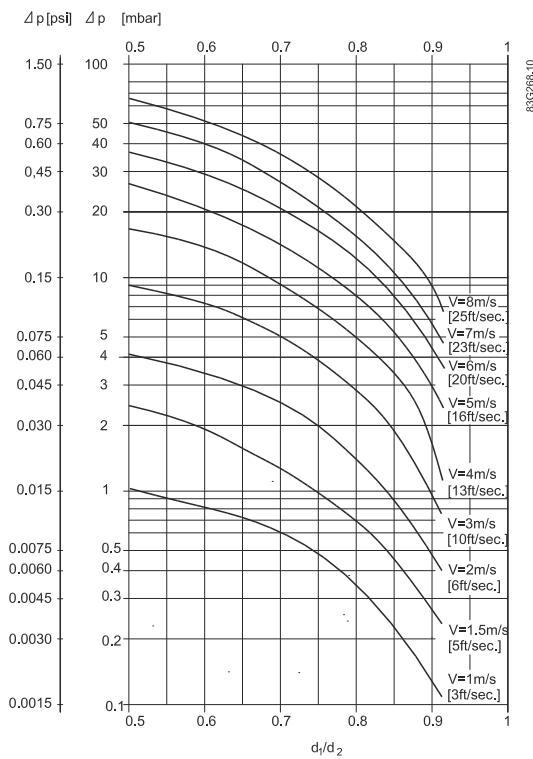

Example:

A flow of 3 m/s ( $v$ ) in a sensor with a diameter reduction from DN 100 to DN 80 ( $d_1/d_2 = 0.8$ ) gives a pressure drop of 2.9 mbar.

## 4.5 Orienting the sensor

### Flow direction

The calibrated flow direction is marked by the arrow on the sensor. Flow in this direction is indicated as positive by default. The accuracy of the sensor does not change with reverse flow.

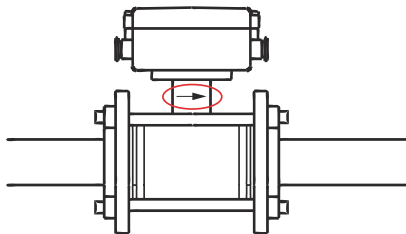

Figure 4-6 Flow direction indicator

## Orientation

The sensor operates in all orientations, but Siemens has the following recommendations:

- Vertical installation with an upwards flow

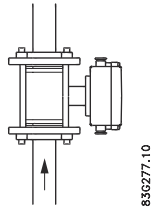

Figure 4-7 Vertical orientation, upwards flow

### NOTICE

#### **Abrasive liquids / liquids containing solid particles**

A vertical installation minimizes wear and deposits in the sensor

### Note

#### **Gas/air bubbles in the liquid**

A vertical installation minimizes any negative effect of gas/air bubbles in the liquid

- Horizontal installation, terminal box upwards or downwards

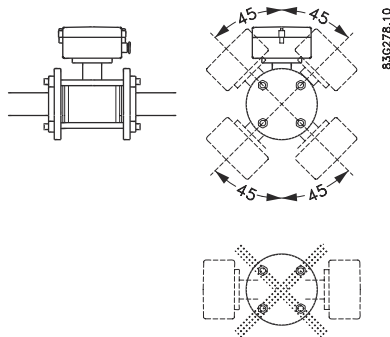

Figure 4-8 Horizontal installation, various terminal box positions

### NOTICE

#### **Do NOT mount the sensor with the terminal box sideways**

This will position the electrodes at the top where there is possibility for air bubbles and at the bottom where there is possibility for mud, sludge, sand etc.

### Note

#### **Empty pipe detection**

For applications with empty pipe detection, the sensor can be tilted 45°, as shown above.

## 4.6 Mounting

- Install the sensor in rigid pipelines in order to support the weight of the meter.
- Center the connecting pipelines axially in order to avoid turbulent flow profiles.
- Use proper gaskets according to liner type (not included).

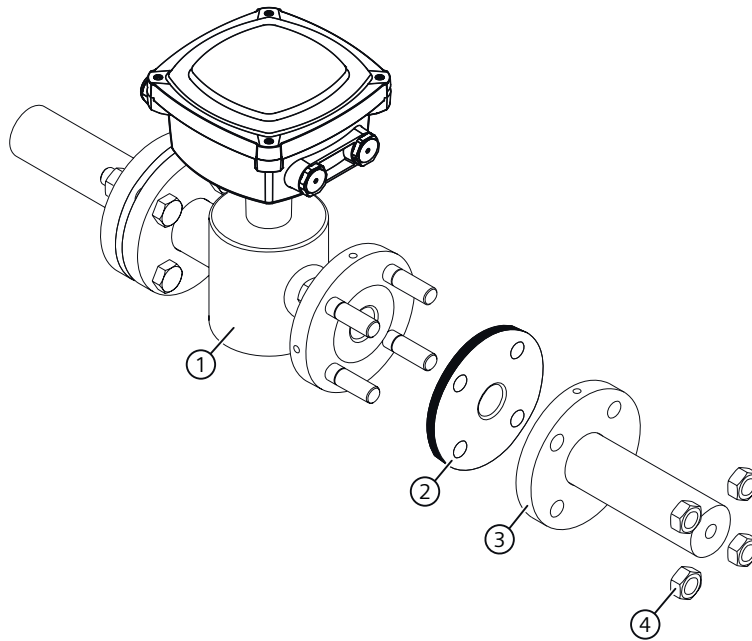

- ① Sensor
- ② Gasket
- ③ Process connection
- ④ Nuts

## Tightening

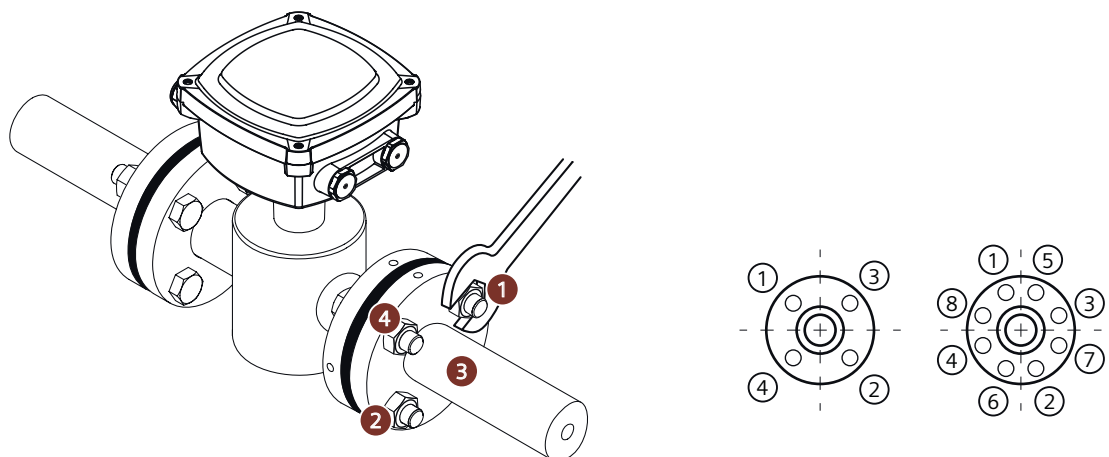

1. Cross-tighten the bolts in the shown sequence.
2. Fasten bolts according to the torques values below.

## 4.7 Torques values

### Note

#### Conversion to F/Lbs

To convert the torque values from Nm to F/Lbs multiply by 0.74.

### Note

Torque values are calculated on the basis of use of gaskets.

Table 4-1 Minimum and maximum torques for EN 1092-1 in Nm

Nominal size		EN 1092-1							
		PN 6		PN 10		PN 16		PN 40	
Liner		EPDM, NBR		EPDM, NBR		EPDM, NBR		EPDM, NBR	
mm	inch	Min.	Max.	Min.	Max.	Min.	Max.	Min.	Max.
15	½	-	-	-	-	-	-	3.2	4
25	1	-	-	-	-	-	-	6.9	7
40	1½	-	-	-	-	-	-	15.0	16
50	2	-	-	-	-	9.2	10	-	-
65	2½	-	-	-	-	6.7	7	-	-
80	3	-	-	-	-	8.2	9	-	-
100	4	-	-	-	-	11.6	12	-	-
125	5	-	-	-	-	16.4	17	-	-
150	6	-	-	-	-	26.8	28	-	-
200	8	-	-	26.1	27	27.9	29	-	-
250	10	-	-	25.5	27	48.8	51	-	-
300	12	-	-	34.0	36	65.1	68	-	-
350	14	-	-	33.7	35	67.0	70	-	-
400	16	-	-	50.7	53	94.3	99	-	-
450	18	-	-	49.4	52	95.1	100	-	-
500	20	-	-	59.8	63	130.6	137	-	-
600	24	-	-	92.3	97	200.6	211	-	-
700	28	-	-	104.9	110	201.0	211	-	-
750	30	-	-	-	-	-	-	-	-
800	32	-	-	149.8	157	282.3	296	-	-
900	36	-	-	158.4	166	298.8	314	-	-
1000	40	-	-	210.1	221	400.6	421	-	-

## Installing/Mounting

### 4.7 Torques values

Nominal size		EN 1092-1							
		PN 6		PN 10		PN 16		PN 40	
Liner		EPDM, NBR		EPDM, NBR		EPDM, NBR		EPDM, NBR	
mm	inch	Min.	Max.	Min.	Max.	Min.	Max.	Min.	Max.
1050	42	-	-	-	-	-	-	-	-
1100	44	-	-	-	-	-	-	-	-
1200	48	-	-	289.1	304	575.4	604	-	-

Table 4-2 Minimum and maximum torques for ANSI B16.5, AWWA C-207, AS 4087 and JIS B2220 in Nm

Nominal size		ANSI B16.5		AWWA C-207		AS 4087		JIS B2220	
		Class 150		Class D		PN 16		10K	
Liner		EPDM, NBR		EPDM, NBR		EPDM, NBR		EPDM, NBR	
mm	inch	Min.	Max.	Min.	Max.	Min.	Max.	Min.	Max.
15	½	3.6	4	-	-	-	-	3.2	4
25	1	7.8	8	-	-	-	-	9.1	10
40	1½	12.9	14	-	-	-	-	15.0	16
50	2	11.9	13	-	-	7.5	8	8.1	9
65	2½	17.2	18	-	-	13.3	14	11.7	12
80	3	21.2	22	-	-	16.4	17	7.2	8
100	4	15.0	16	-	-	23.2	24	10.1	11
125	5	25.0	26	-	-	-	-	17.9	19
150	6	32.8	34	-	-	21.6	23	23.5	25
200	8	51.1	54	-	-	33.6	35	24.4	26
250	10	56.0	59	-	-	61.2	64	39.3	41
300	12	74.7	78	-	-	54.4	57	39.3	41
350	14	103.7	109	-	-	89.3	94	47.9	50
400	16	100.8	106	-	-	111.4	117	69.0	72
450	18	145.9	153	-	-	141.9	149	68.7	72
500	20	140.1	147	-	-	129.6	136	83.7	88
600	24	216.4	227	-	-	203.9	214	121.9	128
700	28	-	-	116.9	123	206.0	216	-	-
750	30	-	-	131.7	138	-	-	-	-
800	32	-	-	178.3	187	338.8	356	-	-
900	36	-	-	194.1	204	350.8	368	-	-
1000	40	-	-	212.3	223	408.5	429	-	-
1050	42	-	-	233.7	245	-	-	-	-
1100	44	-	-	230.7	242	-	-	-	-
1200	48	-	-	246.8	259	446.7	469	-	-



### Torque calculations

All values are theoretical and are calculated making the following assumptions:

1. All bolts are new and material selection is according to EN 1515-1 table 2.
2. Gasket material not exceeding 75 shore A durometer is used between the flowmeter and mating flanges.
3. All bolts are galvanized and adequately lubricated.
4. The values are calculated for use with carbon steel flanges.
5. Flowmeter and mating flanges are correctly aligned.

## 4.8 Potential equalization

To obtain optimum results from the measuring system, the sensor must have the same electrical potential as the liquid being measured.

This is achieved by means of built-in earthing electrodes.

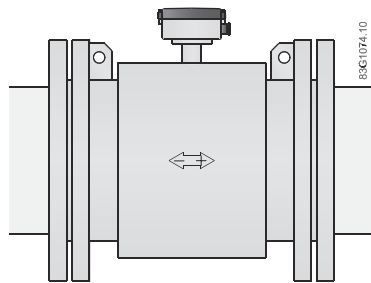



Figure 4-9 Potential equalization with earthing electrodes

### Cathodic protected piping

Special attention must be paid to systems with cathodic protection.

 <b>WARNING</b>
<b>Use in hazardous area!</b>
Cathodic pipe protection is not allowed in hazardous areas

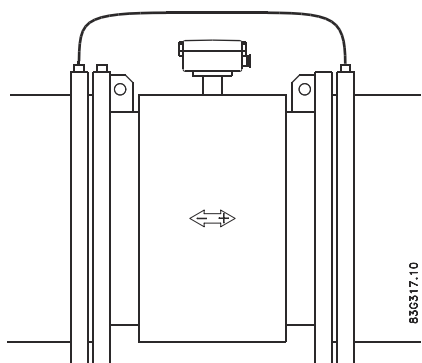

Figure 4-10 Cathodic protection

- Isolate the sensor from cathodic protected pipes using insulated bolts.
- Use bypass cable between the mating flanges

---

**Note**

**Remote mounted sensor versions**

If the above is not acceptable, remote mounted sensors can alternatively be connected as follows:

- Connect coil current cable shield at sensor end via a 1.5  $\mu$ F condensator
  - Make sure that electrode cable shield is not connected at both ends
-

# Connecting

## 5.1 General information

The following contains a short description of how to connect a remote mounted sensor to a transmitter type SITRANS FMT020. For more information, e.g. about wiring of power supply and outputs, refer to the Operating Instructions for the respective transmitter.

### Before connecting

- Check that serial numbers on sensor and SENSORPROM® unit are identical.

 <b>WARNING</b>
<b>The pertinent regulations must be observed for electrical installation.</b> <ul style="list-style-type: none"><li>• Never install the device with the mains voltage switched on!</li><li>• Danger of electric shock!</li><li>• The electrodes and magnetic current line may only be connected when the device is not connected to the power supply.</li><li>• If the housing is under voltage (power supply), the cover may be unscrewed by qualified personnel only.</li></ul>

 <b>WARNING</b>
<b>Mains supply from building installation Class II</b> <p>A switch or circuit breaker (max. 15 A) must be installed in close proximity to the equipment and within easy reach of the operator. It must be marked as the disconnecting device for the equipment.</p>

### Cable specifications

- Only use cables with at least the same degree of protection as the sensor to install the sensor.
- The line length from the cable gland to the terminals must be kept as short as possible. Line loops in the terminal box must be avoided.
- To guarantee the IP67 degree of protection, use cables with the required specifications.

 <b>WARNING</b>
<b>Protective conductor terminal</b>
The required cable is min. AGW16 or 1.5 mm <sup>2</sup> Cu.

 <b>WARNING</b>
<b>Wire insulation</b>
For field wiring installation: Ensure that the national requirements of the country in which the flowmeters are installed is met.

### See also

Cable data (Page 48)

## 5.2 Connecting the sensor

### Before you start

- Read the Safety notes (Page 9)
- Read the Basic safety notes: Installing/mounting
- Read the Basic safety notes: Connecting

## Procedure

1. Remove the lid from the sensor terminal box.

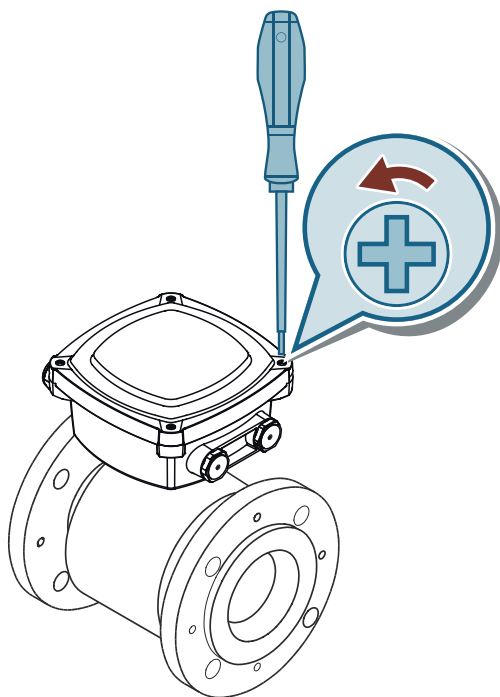

2. Remove SENSORPROM from the holder in the sensor terminal box. The SENSORPROM has to be mounted in the transmitter terminal box. Ensure that the serial number on the SENSORPROM label is identical to the sensor serial number.
3. The terminal board with premounted terminal blocks is included in the delivery of the wall mounting unit. Mount the sensor terminal board in the sensor terminal box. Tighten completely with maximum torque: 1 Nm.

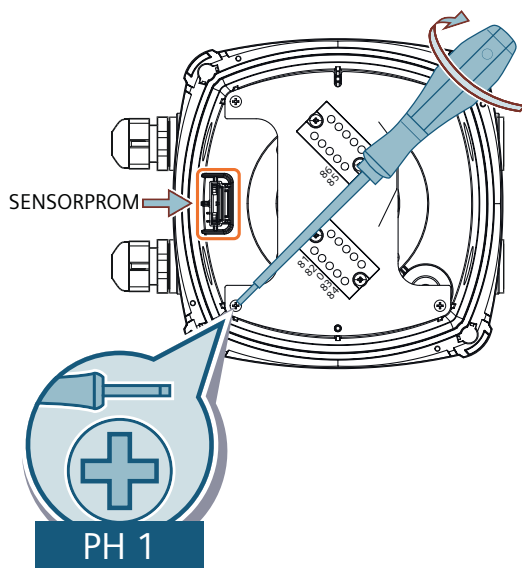

5.2 Connecting the sensor

4. Cut off the black wire on the coil cable. Fit coil and electrode cable through the cable glands.
5. Connect coil cable ① and electrode cable ② in the corresponding terminals on the terminal blocks. Tighten all terminal screws with maximum torque: 0.5 Nm.

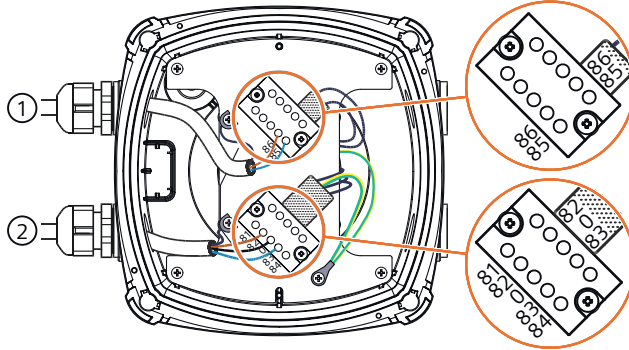

6. Connect the coil and electrode cable shields and grounding cables to the terminal board by using grounding lugs.



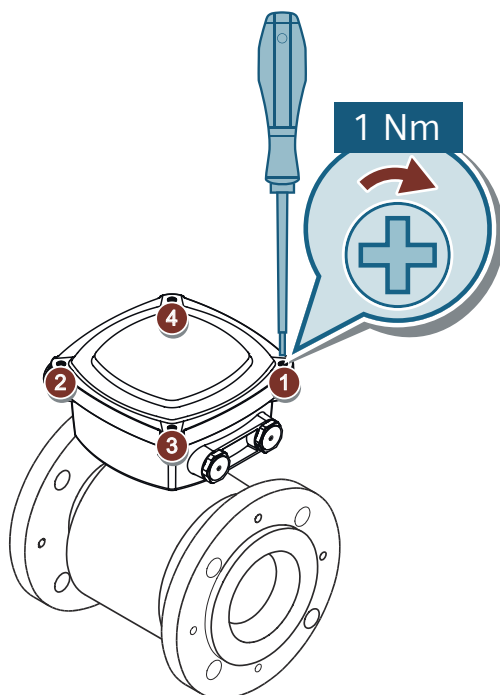

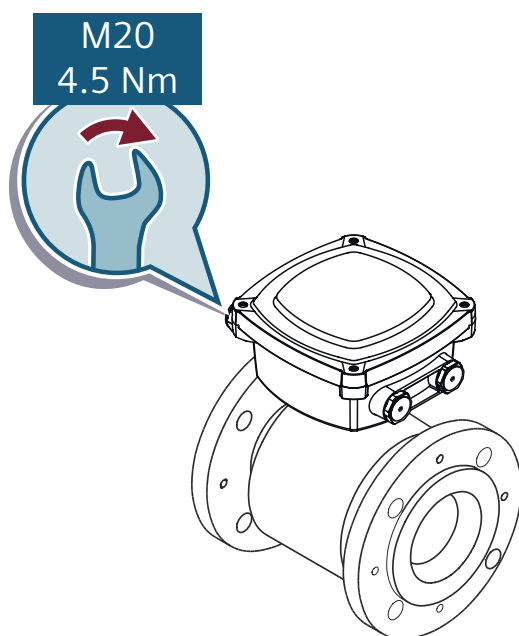

7. Remount terminal box lid by cross tightening as indicated. Do not tighten fully at first to avoid damage to the device.



8. To obtain optimum sealing, tighten cable glands.



### 5.3 Electrical connection

 <b>WARNING</b>
<b>Safety requirement for DC power supply input</b> The DC power supply version is intended to be supplied from one of the following: <ul style="list-style-type: none"><li>• Isolated limited energy source UL61010-1, 3rd ed cl. 9.4</li><li>• Limited power source per UL62368-1</li><li>• PS2 per UL62368-1</li><li>• Class 2 per NEC</li></ul>
 <b>WARNING</b>
<b>Safety requirement for power supply for communication terminals</b> When applicable, the communication terminals are intended to be supplied from one of the following: <ul style="list-style-type: none"><li>• Isolated limited energy source UL61010-1, 3rd ed cl. 9.4</li><li>• Limited power source per UL62368-1</li><li>• PS2 per UL62368-1</li><li>• Class 2 per NEC</li></ul>
 <b>WARNING</b>
<b>Safety requirement for power supply for communication terminals</b> The device is intended to be supplied from an isolated Limited Energy Source per UL61010-1, 3rd ed cl. 9.4 or Limited Power Source per UL62368-1 or Class 2 per NEC.
 <b>WARNING</b>
<b>Disconnecting the device from power</b> To be able to disconnect the device from the electrical supply source, install an external switch or a circuit breaker upstream to the device. Choose a position so that it is easy to operate the disconnecting protection device.
 <b>WARNING</b>
<b>Grounding</b> Connect mains protective ground earth to PE terminal in accordance with diagram (due to class 1 power supply).
 <b>WARNING</b>
<b>High vibration environment</b> Use relay output only in NO mode in an environment with high vibration.



**Note****Mains cable connection**

Mains cable connection with cable glands is allowed for NFPA79 applications only.

---

**Note**

For mains wiring: Use cables in copper material, with a conductor temperature rating of at least 65 °C.

---

**Note**

Terminals 81 and 84 are only to be connected if a special electrode cable with double shielding is used.

---

**Note**

In applications with a risk of low supply voltage below the specifications for more than 10 minutes, install an under voltage relay or protection circuit for DC installations.

---

**Note****Output cables**

Use shielded cables if long cables are used in noisy environments.

---

**Note****Digital output**

If internal resistance of a load exceeds 10 k $\Omega$ , connect an external 10 k $\Omega$  load resistor in parallel to this load.

---

**Note****Mains frequency**

Select the right mains frequency in parameter 2.1.2 for the mains supply frequency, that you are using.

---

For input and output specification refer to Technical specifications (Page 45).

Connection board overview

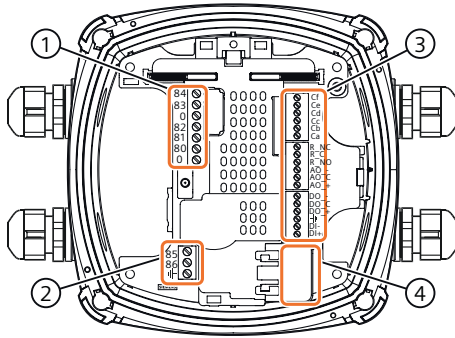

- ① Electrode cable terminals
- ② Coil cable terminals

- ③ Input/Output and communication terminals
- ④ Power supply terminal

Power supply

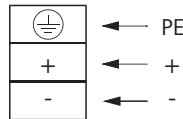
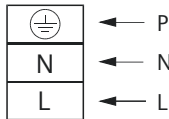



Current output

Table 5-1 Current output

Active output	Passive output
<p>The diagram shows three terminals: AO_-, AO_C, and AO_+. AO_- and AO_+ are connected to a current meter. AO_C is connected to the negative terminal of the meter. A voltage source symbol is shown with a '-' sign at the top and a '+' sign at the bottom.</p>	<p>The diagram shows three terminals: AO_-, AO_C, and AO_+. AO_- and AO_+ are connected to a voltage meter. AO_C is connected to the negative terminal of the meter. A voltage source symbol is shown with a '-' sign at the top and a '+' sign at the bottom, with the text '&gt; 12 V' above it.</p>

## Digital output

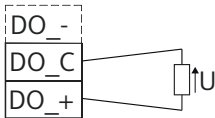
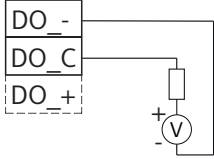
Table 5-2 Digital output - current driven

Active output	Passive output	Menu setup
		Negative:  Positive:   R = Pull up/down resistor < 1 kΩ may be required - depending on Cables/Input resistance

## Relay output

Table 5-3 Relay output

Terminal	Description
R_NC	Normally closed
R_C	Common
R_NO	Normally open

## Communication cable

Ca, Cb, Cc, Cd, Ce, Cf are reserved for communication modules as described in FMT020 Operating Instructions (<http://www.siemens.com/processinstrumentation/documentation>).

### Transmitter to sensor cable connection

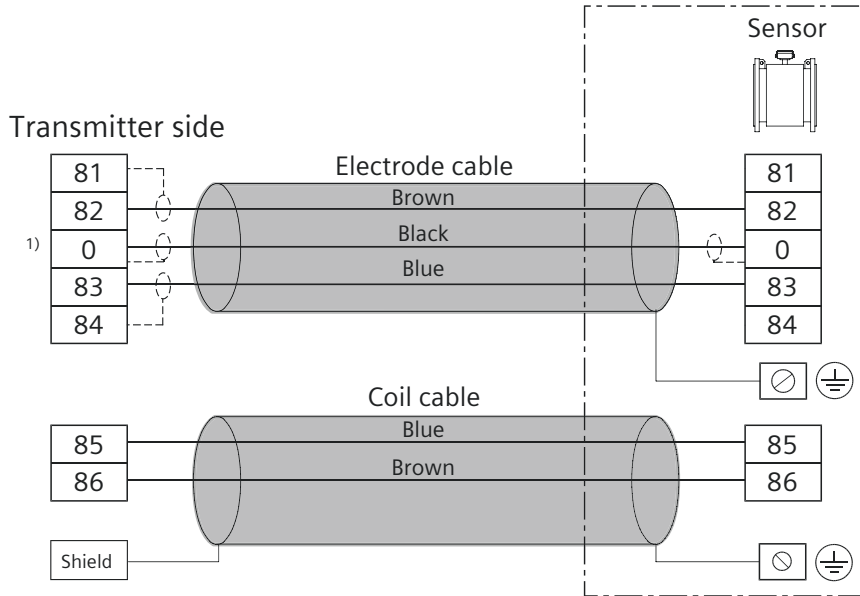

1) Note:  
Special cable with individual wire shields (shown as dotted lines) are only required when using empty pipe function or long cables.

Figure 5-1 Electrode and coil cable

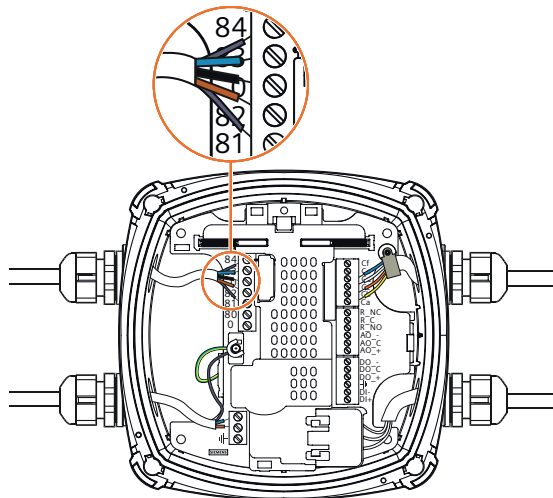

Figure 5-2 Electrode cable with individual wire shields

## 5.4 Installation check

The meter is now ready to go into normal operation - for commissioning and setting of parameters refer to the relevant transmitter manual.

Before commissioning it must be checked that:

- The device has been installed and connected in accordance with the guidelines provided previous in this chapter and in Installing/Mounting (Page 17).

## 5.5 Potting

If sensor is buried or permanently submerged, terminal box must be encapsulated with silicon dielectric gel (non-toxic, transparent and self-healing gel).

### NOTICE

#### Electrical connections

Do **not** pot meter before electrical connections have been made.

- Mix the two components of the potting kit well and pour into terminal box.
- Let cure for approximately 24 hours at approximately 25°C (77°F). Curing time increases by 100% per -10°C (-18°F).

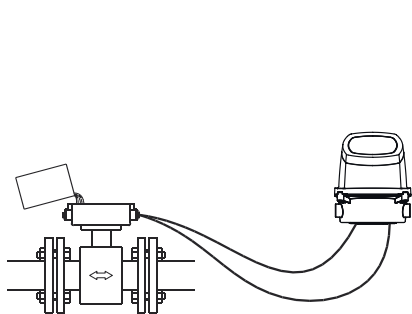

Horizontal orientation

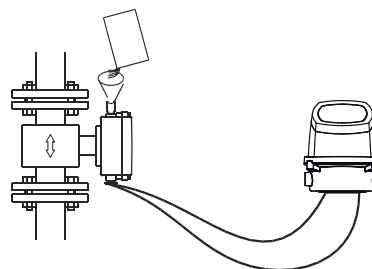

Vertical orientation

### Note

Gel can be penetrated with test instruments or be removed in case of cable replacement.

## 5.6 Direct burial

Recommendations for direct burial of remote sensor:

- Check for visible damages in paint finish !
- Use protection conduit !
- Protect sensor with pea gravel at least 300 mm around sensor. This provides some drainage and also avoids caking sensor with earth. It also helps to locate sensor in case excavation takes place.

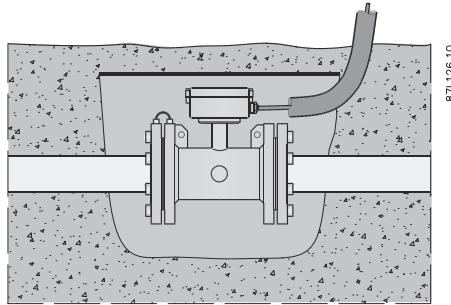

Figure 5-3 Direct burial of sensor

**! CAUTION**

Sensor should not be subject to heavy vehicles applying excessive weight above sensor or pipeline

**NOTICE**

**SENSORPROM memory unit**

Remove the SENSORPROM from terminal box on sensor and relocate in remote transmitter prior to burying sensor.

All sensor data plate information and serial number should be recorded for each sensor prior to burying. This will ensure correct matching with SENSORPROM unit.

**! WARNING**

**Electrical cable identification**

Use suitable coil and electrode cables

Lay electrical cable identification tape above pea gravel before it is covered with earth.

# Service and maintenance

## 6.1 Maintenance

The device is maintenance-free. However, a periodic inspection according to pertinent directives and regulations must be carried out.

An inspection can include check of:

- Ambient conditions
- Seal integrity of the process connections, cable entries, and cover screws
- Reliability of power supply, lightning protection, and grounds

---

### Note

Siemens defines flow sensors as non-repairable products.

---



### WARNING

#### Impermissible repair and maintenance of the device

- Repair and maintenance must be carried out by Siemens authorized personnel only.

## 6.2 Technical support

If you have any technical questions about the device described in these Operating Instructions and do not find the right answers, you can contact Customer Support:

- Via the Internet using the **Support Request:**  
Support request (<http://www.siemens.com/automation/support-request>)
- Via Phone:
  - Europe: +49 (0)911 895 7222
  - America: +1 423 262 5710
  - Asia-Pacific: +86 10 6475 7575

Further information about our technical support is available on the Internet at  
Technical support (<http://support.automation.siemens.com/WW/view/en/16604318>)

### Service & Support on the Internet

In addition to our documentation, we offer a comprehensive knowledge base online on the Internet at:

Service and support (<http://www.siemens.com/automation/service&support>)

6.3 Transportation and storage

There you will find:

- The latest product information, FAQs, downloads, tips and tricks.
- Our newsletter, providing you with the latest information about your products.
- Our bulletin board, where users and specialists share their knowledge worldwide.
- You can find your local contact partner for Industry Automation and Drives Technologies in our partner database.
- Information about field service, repairs, spare parts and lots more under **Services**.

**Additional Support**

If you have additional questions about the device, please contact your local Siemens representative and offices at:

Local contact person (<http://www.automation.siemens.com/partner>)

**6.3 Transportation and storage**

To guarantee sufficient protection during transport and storage, observe the following:

- Keep the original packaging for subsequent transportation.
- Devices/replacement parts should be returned in their original packaging.
- If the original packaging is no longer available, ensure that all shipments are properly packaged to provide sufficient protection during transport. Siemens cannot assume liability for any costs associated with transportation damages.

<b>NOTICE</b>
<b>Insufficient protection during storage</b>
The packaging only provides limited protection against moisture and infiltration. <ul style="list-style-type: none"><li>• Provide additional packaging as necessary.</li></ul>

Special conditions for storage and transportation of the device are listed in Technical specifications (Page 45).



## Handling

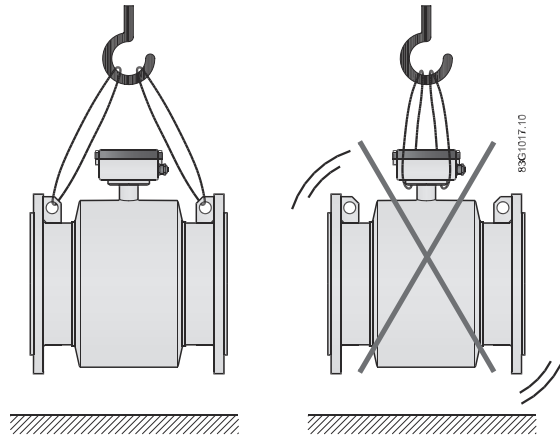

Figure 6-1 Handling of sensor

## 6.4 Return procedure

To return a product to Siemens, see Returns to Siemens ([www.siemens.com/returns-to-siemens](http://www.siemens.com/returns-to-siemens)).

Contact your Siemens representative to clarify if a product is repairable, and how to return it. They can also help with quick repair processing, a repair cost estimate, or a repair report/cause of failure report.

### NOTICE

#### Decontamination

The product may have to be decontaminated before it is returned. Your Siemens contact person will let you know for which products this is required.

## 6.5 Disposal



Devices described in this manual should be recycled. They may not be disposed of in the municipal waste disposal services according to the Directive 2012/19/EC on waste electronic and electrical equipment (WEEE).

Devices can be returned to the supplier within the EC and UK, or to a locally approved disposal service for eco-friendly recycling. Observe the specific regulations valid in your country.

Further information about devices containing batteries can be found at: Information about battery / product return (WEEE) (<https://support.industry.siemens.com/cs/document/109479891/>)



# Diagnostics and Troubleshooting

## 7.1 Sensor check

### Requirement

To check the SITRANS FM sensors the following test instruments will be required:

- Digital Meter/Multimeter
- Ohmmeter "Megger"
- (Moving Coil Meter)

### Sensor check

Remove the transmitter from the sensor or remote position before making the following checks.

### Coil resistance check

- Measure the coil resistance between connection numbers 85 and 86 using a digital meter. Resistance should be within range stated in Coil resistance table (Page 64).

A low reading may indicate moisture within the coil housing or shorted coil turns.

A high reading would indicate an open circuit coil.

---

### Note

In case of deviation from nominal coil values, the sensor is damaged and must be replaced

---

### Coil insulation check

 <b>WARNING</b>
<b>Potential hazard!</b>
Only carry out a coil insulation check in non-hazardous area!

- Megger between connection number 85 and the sensor body. The resistance should be above 20 MΩ.

A low megger reading would indicate the coil insulation is breaking down. This is usually due to fluid ingress into the coil housing.

Sensors with an insulation resistance down to 1 MΩ may still work satisfactorily but this is not guaranteed.

### Electrode resistance check

- Measure the electrode resistance between connections 82 and 0 with a moving coil meter. With a sensor full of fluid the resistance should be between 5 k $\Omega$  and 50 k $\Omega$ . If the sensor is empty the resistance will be infinite.
- Repeat the resistance measurements between connections 83 and 0. The results should be the same.

If the resistance is low there may be a short on the electrodes or wiring (in the case of a remote mounted transmitter). Alternatively there may be water ingress or moisture in the terminal box.

If the resistance is high and the pipe is completely full of fluid check the following:

1. Fluid is electrically conductive.
2. Electrodes are not coated with grease or any deposit.
3. Electrode circuit is not open.
4. Remote mounted transmitter has a 3 core cable with an overall shield continuously from sensor to transmitter, including junction boxes and terminal rails inside panels.
5. Shield is connected to 0 or to earth terminal (PE) on sensor.

---

#### Note

##### Sensors removed from line

For sensors removed from line with dry bore, use megger between terminal 82 and compression plate, and 83 and compression plate to show any water ingress behind electrodes or within enclosure.

---

## 7.2 Fluctuating process values

### Question

Why do the displayed process values fluctuate when the electrode cable is moved?

### Answer

There can be several causes for fluctuating process values:

- Deposits on electrodes
  - Clean the electrodes.
- Defect electrode cable
  - Replace the cable
- Incorrect cable connection
  - Connect the electrode cable (82, 83, 0 and shield) according to the instructions in Electrical connection (Page 32)

# Technical specifications

## 8.1 FMS500

Table 8-1 Technical specifications

Version	FMS500
Product characteristic	EPDM or NBR lining
Design and nominal size	<i>Coned sensor:</i> <ul style="list-style-type: none"> <li>• DN 15 to 300 (½" to 12")</li> </ul> <i>Full bore sensor:</i> <ul style="list-style-type: none"> <li>• DN 350 to 1200 (14" to 48")</li> </ul>
Measuring principle	Electromagnetic induction
Excitation frequency (Mains supply: 50 Hz/60 Hz)	<i>DN 15 to 65 (½" to 2½"):</i> <ul style="list-style-type: none"> <li>• 12.5 Hz / 15 Hz</li> </ul> <i>DN 80 to 150 (3" to 6"):</i> <ul style="list-style-type: none"> <li>• 6.25 Hz / 7.5 Hz</li> </ul> <i>DN 200 to 300 (8" to 12"):</i> <ul style="list-style-type: none"> <li>• 3.125 Hz / 3.75 Hz</li> </ul> <i>DN 350 to 1200 (14" to 48"):</i> <ul style="list-style-type: none"> <li>• 1.5625 Hz / 1.875 Hz</li> </ul>

Technical specifications

8.1 FMS500

Table 8-2 Process connections

Version	FMS500
EN 1092-1	PN 6 <ul style="list-style-type: none"> <li>DN 1400 to 1200 (56" to 48") Raised face flanges</li> </ul> PN 10 (145 psi): <ul style="list-style-type: none"> <li>DN 200 to 300 (8" to 12") Flat face flanges</li> </ul> PN 10 (145 psi): <ul style="list-style-type: none"> <li>DN 350 to 1200 (14" to 48") Raised face flanges</li> </ul> PN 16 (232 psi): <ul style="list-style-type: none"> <li>DN 50 to 300 (2" to 12") Flat face flanges</li> </ul> PN 16 (232 psi): <ul style="list-style-type: none"> <li>DN 350 to 1200 (14" to 48") Raised face flanges</li> </ul> PN 40 (580 psi): <ul style="list-style-type: none"> <li>DN 15 to 40 (½" to 1½") Flat face flanges</li> </ul>
ANSI B16.5	Class 150 lb: ½" to 24"
AWWA C-207	Class D: <ul style="list-style-type: none"> <li>28" to 78", Flat face flanges</li> </ul>
AS4087	PN 16 (230 psi): <ul style="list-style-type: none"> <li>DN 50 to 1200 (2" to 48")</li> </ul>
JIS B 2220	K10 (1" to 24")

Table 8-3 Rated operating conditions

Version	FMS500
Ambient temperature	
Sensor	-20 to +70 °C (-4 to +158 °F)
With compact transmitter FMT020	-20 to +65 °C (-4 to +149 °F)
Operating pressure [abs. bar] <sup>1</sup>	
	DN 15 to 40 (½" to 1½") 0.01 to 40 bar (0.15 to 580 psi) DN 50 to 300 (2" to 12") <sup>2</sup> 0.03 to 20 bar (0.44 to 290 psi) DN 350 to 1200 (14" to 48") 0.01 to 16 bar (0.15 to 232 psi)
Enclosure rating	
Standard	IP66/67, NEMA 4X/6
Optional	IP68 and NEMA 6P (2m, 10 days) for sensor in remote design IP68 and NEMA 6P (10m, continuously) for sensor in remote design

Version	FMS500
Corrosive category	C4 (C5 optional) according to ISO 12944-2
Pressure drop	DN 15 and 25 (½" and 1"): <ul style="list-style-type: none"> <li>Max. 20 mbar (0.29 psi) at 1 m/s (3 ft/s)</li> </ul> DN 40 to 300 (1½" to 12"): <ul style="list-style-type: none"> <li>Max. 25 mbar (0.36 psi) at 3 m/s (10ft/s)</li> </ul> DN 350 to 1200 (14" to 48"): <ul style="list-style-type: none"> <li>Insignificant</li> </ul>
Test pressure	1.5 x PN (where applicable)
Mechanical load (vibration) - compact version	
With compact transmitter FMT020	<ul style="list-style-type: none"> <li>Vibration, sinusoidal according to IEC 60068-2-6: 1 g peak</li> <li>Vibration broad-band random, according to IEC 60068-2-64: 1.54 g rms</li> </ul>
Mechanical load (vibration) - remote version	
Sensor	<ul style="list-style-type: none"> <li>Vibration, sinusoidal according to IEC 60068-2-6: 2 g peak</li> <li>Vibration broad-band random, according to IEC 60068-2-64: 1.54 g rms</li> </ul>
Transmitter FMT020	<ul style="list-style-type: none"> <li>Vibration, sinusoidal according to IEC 60068-2-6: 0.7 g peak</li> <li>Vibration broad-band random, according to IEC 60068-2-64: 1.54 g rms</li> </ul>
Process fluid temperature	
NBR	-10 to +70 °C (14 to 158 °F)
EPDM	-10 to +70 °C (14 to 158 °F)
EMC	EMC 2014/30/EU

<sup>1</sup> Maximum operating pressure decreases with increasing operating temperature

<sup>2</sup> For PTB K7.2 DN 15 to 1200

Table 8-4 Design

Version	FMS500
Housing and flange material	Carbon steel, with corrosion resistant coating of corrosive category C4 or C5, according to ISO 12944-2
Measuring pipe	AISI 304 (1.4301)
Electrodes	Hastelloy
Grounding electrodes (standard)	Hastelloy
Terminal box	Polycarbonate



8.2 Cable data

Table 8-5 Certificates and approvals

Version	FMS500
Calibration	Zero-point, 2 x 25 % and 2 x 90 %
Standard production calibration, calibration report shipped with sensor	
Drinking water approvals	<p>EPDM liner:</p> <ul style="list-style-type: none"> <li>• ANSI/NSF 61 Standard (Cold water, US)</li> <li>• WRAS (WRc, BS6920 cold water, GB)</li> <li>• ACS (F)</li> <li>• DVGW W270 (G)</li> <li>• Belgaqua</li> <li>• AS/NZS 4020 (Australia/New Zealand)</li> <li>• GB/T 5750 (China)</li> </ul>

## 8.2 Cable data

### Description

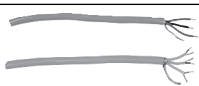
Cable for standard electrode or coil	
Electrode cable, double shielded	
Cable kit with standard coil cable and electrode cable double shielded (also available as low noise cable for MAG 1100 sensor)	

### Standard applications

Table 8-6 Technical data, standard application cables

		Coil cable	Standard electrode cable
<b>Basic data</b>	No. of conductors	2	3
	Min. sqr. area	0.5 mm <sup>2</sup>	0.2 mm <sup>2</sup>
	Shield	Yes	Yes
	Max. capacitance	N/A	350 pF/m
<b>Max. cable loop resistance</b>	Media temperature:		
	< 100 °C (212 °F)	40 Ω	N/A
	> 200 °C (392 °F)	6 Ω	N/A
<b>Cable glands on sensor and transmitter</b>	M20x1.5 gland - Cable ø 5 to 13 mm (0.20 to 0.51 inches)		
	½ NPT gland - cable ø 5 to 9 mm (0.20 to 0.35 inches)		



### Special applications, for example low conductivity or electrical noise

Table 8-7 Technical data, special application cables

		Coil cable	Special electrode cable
Basic data	No. of conductors	3	3
	Sqr. area	1.5 mm <sup>2</sup>	0.25 mm <sup>2</sup>
	Shield	Yes	Double
	Color code	Brown, blue, black	Brown, blue, black
	Outside color	Grey	Grey
	Ext. diameter	7.8 mm	8.1 mm
	Conductor	Flexible CU	Flexible CU
	Isolation material	PVC	PVC
Ambient temperature	Flexible installation	-5 to +70°C (23 to 158°F)	-5 to +70°C (23 to 158°F)
	Non-flexible installation	-30 to +70°C (-22 to 158°F)	-30 to +70°C (-22 to 158°F)
Cable parameter	Capacity	161.50 pF/m	N/A
	Inductance	0.583 μH/m	N/A
	L/R	43.83 μH/Ω	N/A

## 8.3 Effect of temperature on working pressure

Effect of temperature on working pressure.

Table 8-8 Metric measures (pressure in bar)

Flange specifications	Flange rating	Temperature (°C)			
		-5	10	50	90
Sizes DN25 to 2000					
EN 1092-1	PN 10	10.0	10.0	9.7	9.4
	PN 16	16.0	16.0	15.5	15.1
	PN 40	40.0	40.0	38.7	37.7
ANSI B16.5	150 lb	19.7	19.7	19.3	18.0
AWWA C-207	Class D	10.3	10.3	10.3	10.3
AS		16.0	16.0	15.5	15.1
JIS	10K	14.0	14.0	14.0	14.0
Sizes DN 15 to 300					
EN 1092-1	PN 10	10.0	10.0	10.0	8.2
	PN 16	10.0	16.0	16.0	13.2
	PN 40	40.0	40.0	38.7	37.7
ANSI B16.5	150 lb	10.0	19.7	19.7	16.2
AS		16.0	16.0	16.0	13.2
JIS		14.0	14.0	14.0	

8.4 Process fluid conductivity

Table 8-9 Imperial measures (pressure in psi)

Flange specifications	Flange rating	Temperature (°F)			
		23	50	120	200
Sizes 1" to 78"					
EN 1092-1	PN 10	145	145	141	136
	PN 16	232	232	225	219
	PN 40	580	580	561	547
ANSI B16.5	150 lb	286	286	280	261
AWWA C-207	Class D	150	150	150	150
Sizes ½" to 12"					
EN 1092-1	PN 10	145	145	145	119
	PN 16	145	232	232	191
ANSI B16.5	150 lb	145	286	286	235

## 8.4 Process fluid conductivity

### Compact installation

Liquids with an electrical conductivity  $\geq 5 \mu\text{S/cm}$ .

### Remote installation

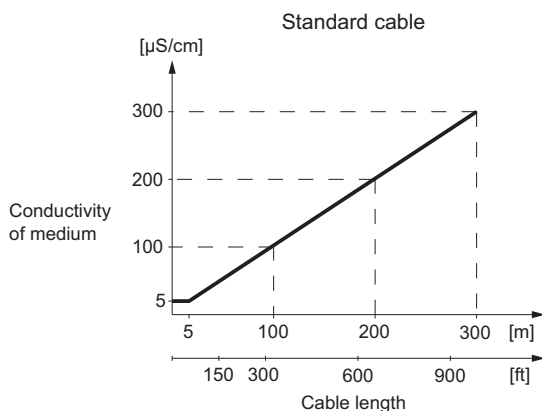

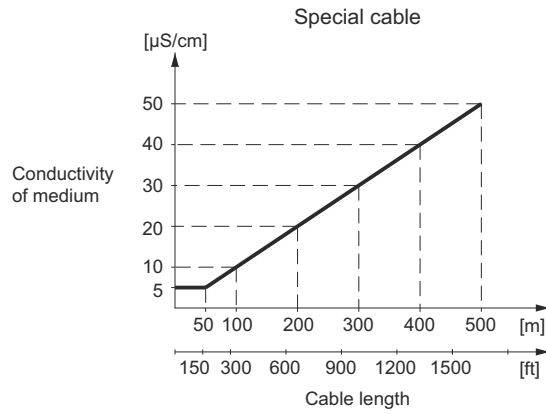

## 8.5 Liner selection

Liner	Applications
EPDM	Drinking water applications (not hydrocarbons)
NBR	General purpose, sea waters

## 8.6 Electrode selection

Electrodes	
Hastelloy C	The preferred choice for water and wastewater, chemicals, food and beverage, and pharmaceutical industries

# 8.7 Sizing tables

## Sizing table (DN 2 to DN 2000)

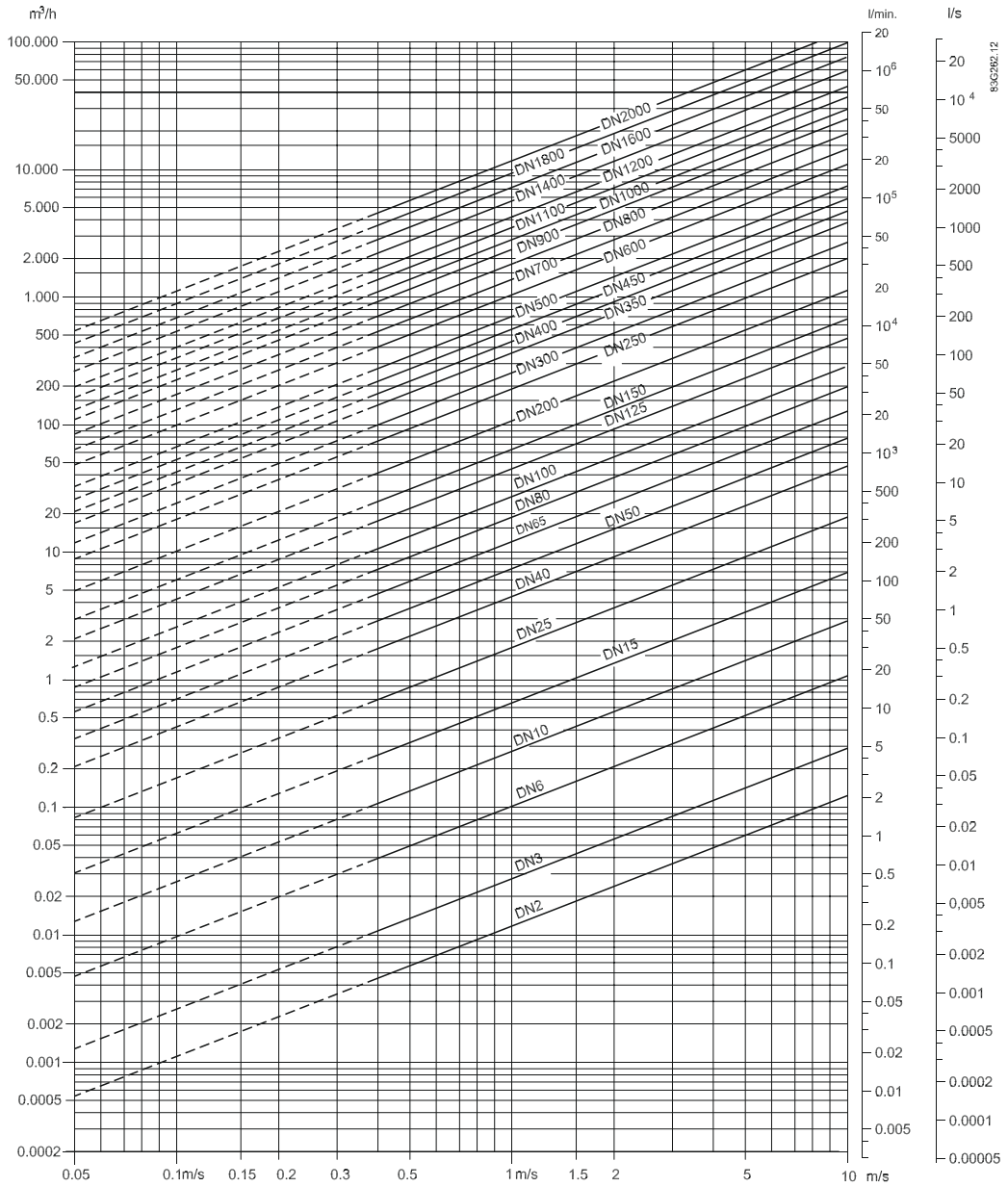

**Sizing table (DN 1/12" to DN 78")**

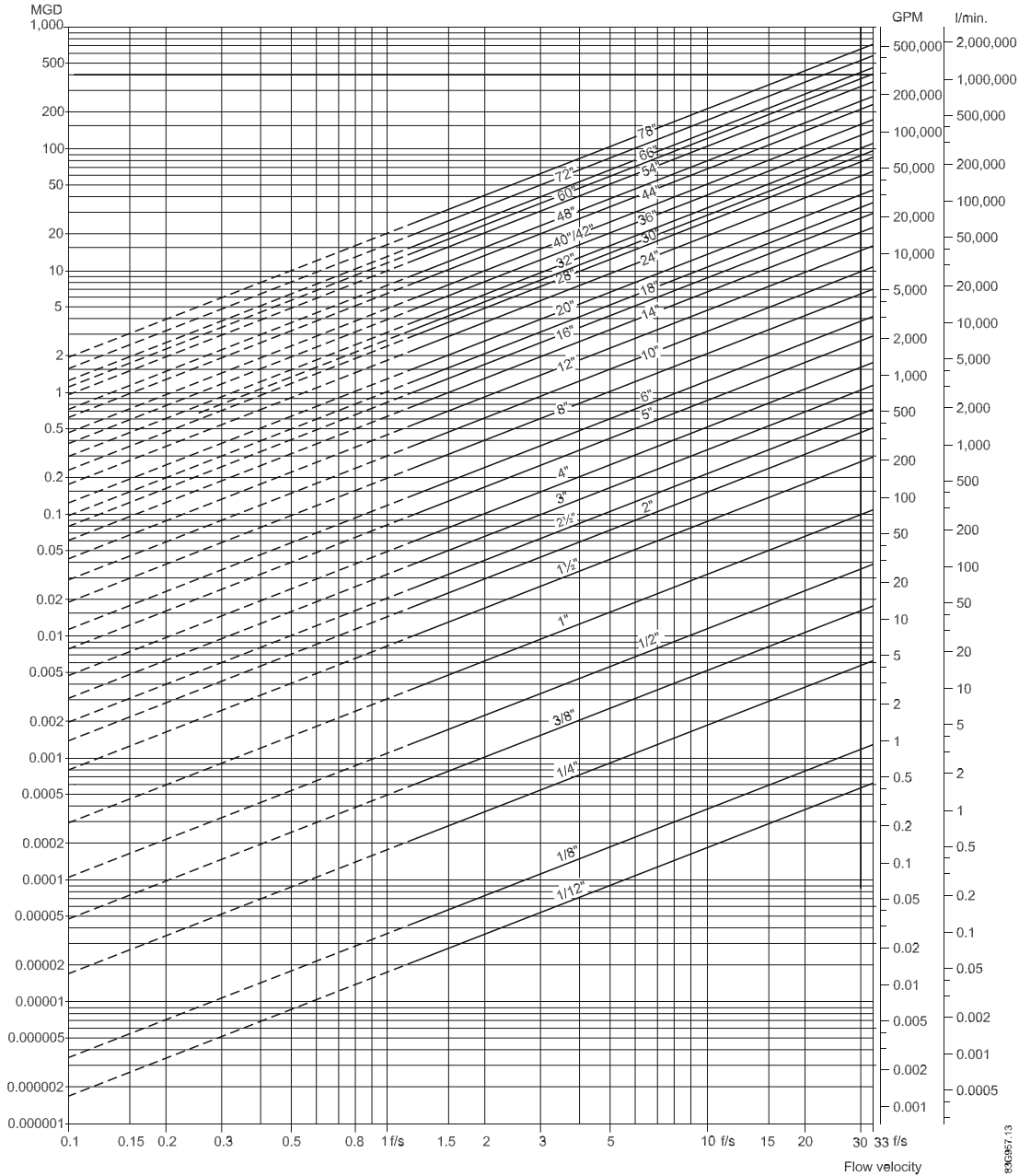

The tables show the relationship between flow velocity  $v$ , flow quantity  $Q$  and sensor dimension DN.

**Guidelines for selection of sensor**

Min. measuring range: 0 to 0.25 m/s (0 to 0.8 ft/s)

Max. measuring range: 0 to 10 m/s (0 to ft/s)

Normally the sensor size is selected so that the nominal flow velocity  $v$  lies within the measuring range 1 to 3 m/s (1 to 15 ft/s).

8.8 Dimensions and weight

Flow velocity calculation formula:

(metric measures)

$$V = \frac{1273.24 \times Q \text{ [l/s]}}{DN^2 \text{ [mm]}} \text{ [m/s]} \text{ or } V = \frac{353.68 \times Q \text{ [m}^3\text{/h]}}{DN^2 \text{ [mm]}} \text{ [m/s]}$$

(imperial measures)

$$V = \frac{0.408 \times Q \text{ [GPM]}}{(\text{Pipe ID})^2 \text{ [inch]}} \text{ [ft/s]} \text{ or } V = \frac{283.67 \times Q \text{ [MGD]}}{(\text{Pipe ID})^2 \text{ [inch]}} \text{ [ft/s]}$$

8.8 Dimensions and weight

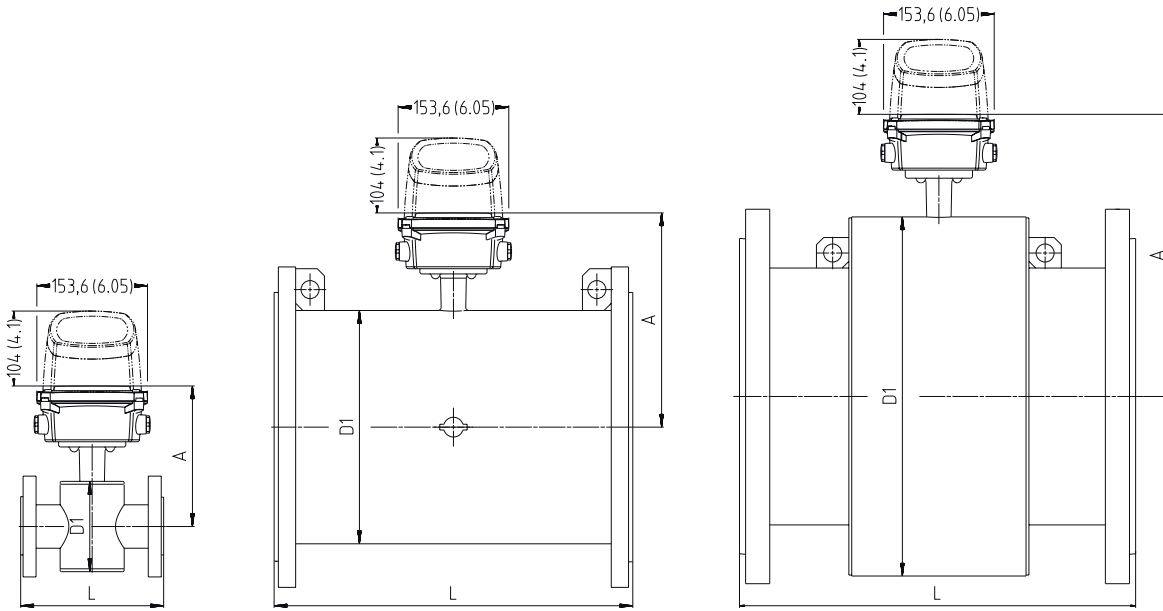

Figure 8-1 FMS500 with FMT020

Dimensions

Table 8-10 Nominal size A

Nominal size		A	
		NBR or EPDM liner	
mm	inch	mm	inch
15	½	170	6.7
25	1	180	7.1
40	1½	195	7.7
50	2	181	7.1
65	2½	187	7.4
80	3	193	7.6

Nominal size		A	
		NBR or EPDM liner	
mm	inch	mm	inch
100	4	200	7.9
125	5	210	8.3
150	6	225	8.9
200	8	250	9.8
250	10	277	10.9
300	12	303	11.9
350	14	375	14.8
400	16	400	15.7
450	18	431	17
500	20	456	18
600	24	507	20
700	28	557	21.9
750	30	584	23
800	32	609	24
900	36	656	25.8
1000	40	707	27.8
1050	42	707	27.8
1100	44	758	29.8
1200	48	813	32

Table 8-11 Nominal size L

Nominal size		L													
		PN 10		PN 16 <sup>1)</sup>		PN 40		Class 150		AWWA C-207		AS 16		JIS10K	
mm	inch	mm	inch	mm	inch	mm	inch	mm	inch	mm	inch	mm	inch	mm	inch
15	½	N/A	N/A	N/A	N/A	200	7.9	200	7.9	N/A	N/A	N/A	N/A	200	7.9
25	1	N/A	N/A	N/A	N/A	200	7.9	200	7.9	N/A	N/A	N/A	N/A	200	7.9
40	1½	N/A	N/A	N/A	N/A	200	7.9	200	7.9	N/A	N/A	N/A	N/A	200	7.9
50	2	N/A	N/A	200	7.9	N/A	N/A	200	7.9	N/A	N/A	200	7.9	200	7.9
65	2½	N/A	N/A	200	7.9	N/A	N/A	200	7.9	N/A	N/A	200	7.9	200	7.9
80	3	N/A	N/A	200	7.9	N/A	N/A	200	7.9	N/A	N/A	200	7.9	200	7.9
100	4	N/A	N/A	250	9.8	N/A	N/A	250	9.8	N/A	N/A	250	9.8	250	9.8
125	5	N/A	N/A	250	9.8	N/A	N/A	250	9.8	N/A	N/A	N/A	N/A	250	9.8
150	6	N/A	N/A	300	11.8	N/A	N/A	300	11.8	N/A	N/A	300	11.8	300	11.8
200	8	350	13.8	350	13.8	N/A	N/A	350	13.8	N/A	N/A	350	13.8	350	13.8
250	10	450	17.7	450	17.7	N/A	N/A	450	17.7	N/A	N/A	450	17.7	450	17.7
300	12	500	19.7	500	19.7	N/A	N/A	500	19.7	N/A	N/A	500	19.7	500	19.7
350	14	550	21.7	550	21.7	N/A	N/A	550	21.7	N/A	N/A	550	21.7	550	21.7
400	16	600	23.6	600	23.6	N/A	N/A	600	23.6	N/A	N/A	600	23.6	600	23.6
450	18	600	23.6	600	23.6	N/A	N/A	600	23.6	N/A	N/A	600	23.6	600	23.6

Technical specifications

8.8 Dimensions and weight

Nominal size		L													
		PN 10		PN 16 <sup>1)</sup>		PN 40		Class 150		AWWA C-207		AS 16		JIS10K	
mm	inch	mm	inch	mm	inch	mm	inch	mm	inch	mm	inch	mm	inch	mm	inch
500	20	600	23.6	600	23.6	N/A	N/A	600	23.6	N/A	N/A	600	23.6	600	23.6
600	24	600	23.6	600	23.6	N/A	N/A	600	23.6	N/A	N/A	600	23.6	600	23.6
700	28	700	27.6	700	27.6	N/A	N/A	N/A	N/A	700	27.6	700	27.6	N/A	N/A
750	30	N/A	N/A	N/A	N/A	N/A	N/A	N/A	N/A	750	29.5	N/A	N/A	N/A	N/A
800	32	800	31.5	800	31.5	N/A	N/A	N/A	N/A	800	31.5	800	31.5	N/A	N/A
900	36	900	35.4	900	35.4	N/A	N/A	N/A	N/A	900	35.4	900	35.4	N/A	N/A
1000	40	1000	39.4	1000	39.4	N/A	N/A	N/A	N/A	1000	39.4	1000	39.4	N/A	N/A
1050	42	N/A	N/A	N/A	N/A	N/A	N/A	N/A	N/A	1000	39.4	N/A	N/A	N/A	N/A
1100	44	N/A	N/A	N/A	N/A	N/A	N/A	N/A	N/A	1100	43.3	N/A	N/A	N/A	N/A
1200	48	1200	47.2	1200	47.2	N/A	N/A	N/A	N/A	1200	47.2	1200	47.2	N/A	N/A

Weight

Table 8-12 Weight

Nominal size		PN 10		PN 16 <sup>1)</sup>		PN 40		Class 150		AWWA C-207		AS 16		JIS10K	
mm	inch	kg	lbs	kg	lbs	kg	lbs	kg	lbs	kg	lbs	kg	lbs	kg	lbs
15	½	N/A	N/A	N/A	N/A	5	11	5	11	N/A	N/A	N/A	N/A	5	11
25	1	N/A	N/A	N/A	N/A	6	13	6	13	N/A	N/A	N/A	N/A	6	13
40	1½	N/A	N/A	N/A	N/A	9	20	9	20	N/A	N/A	N/A	N/A	9	20
50	2	N/A	N/A	10	22	N/A	N/A	10	22	N/A	N/A	10	22	10	22
65	2½	N/A	N/A	12	26	N/A	N/A	12	26	N/A	N/A	12	26	12	26
80	3	N/A	N/A	13	29	N/A	N/A	13	29	N/A	N/A	13	29	13	29
100	4	N/A	N/A	17	37	N/A	N/A	18	40	N/A	N/A	17	37	17	37
125	5	N/A	N/A	20	44	N/A	N/A	21	46	N/A	N/A	N/A	N/A	20	44
150	6	N/A	N/A	27	60	N/A	N/A	30	66	N/A	N/A	21	46	26	57
200	8	38	84	39	86	N/A	N/A	47	104	N/A	N/A	34	75	35	77
250	10	52	115	56	123	N/A	N/A	64	141	N/A	N/A	48	106	51	112
300	12	62	137	72	159	N/A	N/A	92	203	N/A	N/A	61	134	59	130
350	14	99	218	115	254	N/A	N/A	131	289	N/A	N/A	106	234	88	194
400	16	121	267	143	315	N/A	N/A	161	355	N/A	N/A	124	273	113	249
450	18	144	317	177	390	N/A	N/A	182	401	N/A	N/A	145	320	135	298
500	20	165	364	222	489	N/A	N/A	217	478	N/A	N/A	175	386	151	333
600	24	225	496	321	708	N/A	N/A	305	672	N/A	N/A	285	628	179	395
700	28	272	600	331	730	N/A	N/A	N/A	N/A	284	626	350	772	N/A	N/A
750	30	N/A	N/A	N/A	N/A	N/A	N/A	N/A	N/A	331	730	N/A	N/A	N/A	N/A
800	32	300	661	386	851	N/A	N/A	N/A	N/A	394	869	485	1069	N/A	N/A
900	36	372	820	482	1063	N/A	N/A	N/A	N/A	487	1074	645	1422	N/A	N/A
1000	40	454	1001	672	1482	N/A	N/A	N/A	N/A	589	1299	696	1534	N/A	N/A
1050	42	N/A	N/A	N/A	N/A	N/A	N/A	N/A	N/A	693	1528	N/A	N/A	N/A	N/A



Nominal size		PN 10		PN 16 <sup>1)</sup>		PN 40		Class 150		AWWA C-207		AS 16		JIS10K	
mm	inch	kg	lbs	kg	lbs	kg	lbs	kg	lbs	kg	lbs	kg	lbs	kg	lbs
1100	44	N/A	N/A	N/A	N/A	N/A	N/A	N/A	N/A	774	1706	N/A	N/A	N/A	N/A
1200	48	728	1605	1116	2460	N/A	N/A	N/A	N/A	916	2019	1116	2460	N/A	N/A



# Product documentation and support

## A.1 Product documentation

Process instrumentation product documentation is available in the following formats:

- Certificates (<http://www.siemens.com/processinstrumentation/certificates>)
- Downloads (firmware, EDDs, software) (<http://www.siemens.com/processinstrumentation/downloads>)
- Catalog and catalog sheets (<http://www.siemens.com/processinstrumentation/catalogs>)
- Manuals (<http://www.siemens.com/processinstrumentation/documentation>)  
You have the option to show, open, save, or configure the manual.
  - "Display": Open the manual in HTML5 format
  - "Configure": Register and configure the documentation specific to your plant
  - "Download": Open or save the manual in PDF format
  - "Download as html5, only PC": Open or save the manual in the HTML5 view on your PC

You can also find manuals with the Mobile app at Industry Online Support (<https://support.industry.siemens.com/cs/ww/en/sc/2067>). Download the app to your mobile device and scan the device QR code.

### Product documentation by serial number

Using the PIA Life Cycle Portal, you can access the serial number-specific product information including technical specifications, spare parts, calibration data, or factory certificates.

#### Entering a serial number

1. Open the PIA Life Cycle Portal (<https://www.pia-portal.automation.siemens.com>).
2. Select the desired language.
3. Enter the serial number of your device. The product documentation relevant for your device is displayed and can be downloaded.

To display factory certificates, if available, log in to the PIA Life Cycle Portal using your login or register.

#### Scanning a QR code

1. Scan the QR code on your device with a mobile device.
2. Click "PIA Portal".

To display factory certificates, if available, log in to the PIA Life Cycle Portal using your login or register.

## A.2 Technical support

### Technical support

If this documentation does not completely answer your technical questions, you can enter a Support Request (<http://www.siemens.com/automation/support-request>).

For help creating a support request, view this video here ([www.siemens.com/opensr](http://www.siemens.com/opensr)).

Additional information on our technical support can be found at Technical Support (<http://www.siemens.com/automation/csi/service>).

### Service & support on the Internet

In addition to our technical support, Siemens offers comprehensive online services at service & support (<http://www.siemens.com/automation/service&support>).

### Contact

If you have further questions about the device, contact your local Siemens representative, by doing the following:

1. Visit Contact at Siemens (<http://www.automation.siemens.com/partner>).
2. Select "All Products and Branches" > "Products & Services" > "Industrial automation".
3. Choose either "Process analytics" or "Process instrumentation", depending on your product.
4. Select the product category ("Pressure measurement", for example), then select your product.
5. Click "Search".  
The contacts for your product in all regions display.

Contact address for business unit:

Siemens AG  
Digital Industries  
Process Automation  
Östliche Rheinbrückenstr. 50  
76187 Karlsruhe, Germany

## Appendix

### B.1 Flange mating dimensions (metric)

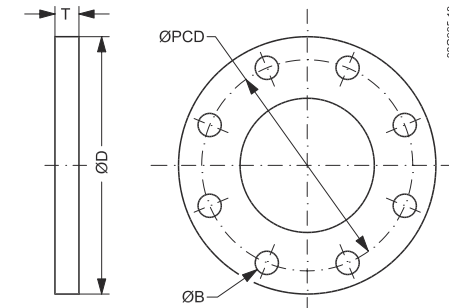

Figure B-1 Flange mating dimensions

Table B-1 Flange mating dimensions (metric) for 7ME6520

DN mm	Dimensions (mm)				Bolting	
	D	PCD	T	B	Holes	Bolts
<b>PN10</b>						
200	340	295	24	22	8	M20
250	395	350	26	22	12	M20
300	445	400	26	22	12	M20
350	505	460	30	22	16	M20
400	565	515	32	26	16	M24
450	615	565	36	26	20	M24
500	670	620	38	26	20	M24
600	780	725	42	30	20	M27
700	895	840	35	30	24	M27
800	1015	950	38	33	24	M30
900	1115	1050	38	33	28	M30
1000	1230	1160	44	36	28	M33
1200	1455	1380	55	39	32	M36
<b>PN16</b>						
50	165	125	20	18	4	M16
65	185	145	20	18	8	M16
80	200	160	20	18	8	M16
100	220	180	22	18	8	M16
125	250	210	22	18	8	M16
150	285	240	24	22	8	M20
200	340	295	26	22	12	M20
250	405	355	30	26	12	M24

Appendix

B.1 Flange mating dimensions (metric)

DN mm	Dimensions (mm)				Bolting	
	D	PCD	T	B	Holes	Bolts
300	460	410	36	26	12	M24
350	520	470	37	26	16	M24
400	580	525	41	30	16	M27
450	640	585	46	30	20	M27
500	715	650	50	33	20	M30
600	840	770	56	36	20	M33
700	910	840	40	36	24	M33
800	1025	950	41	39	24	M36
900	1125	1050	48	39	28	M36
1000	1255	1170	59	42	28	M39
1200	1485	1390	78	48	32	M45
<b>PN40</b>						
15	95	65	14	14	4	M12
25	115	85	16	14	4	M12
40	150	110	18	18	4	M16
<b>150 lb</b>						
15	89	60	12	16	4	M12
25	108	79	16	16	4	M12
40	127	98	19	16	4	M12
50	150	121	21	19	4	M16
65	180	140	24	19	4	M16
80	190	152	26	19	4	M16
100	230	191	27	19	8	M16
125	255	216	28	22	8	M20
150	279	241	31	22	8	M20
200	343	298	34	22	8	M20
250	406	362	38	25	12	M24
300	483	432	42	25	12	M24
350	535	476	35	29	12	M27
400	595	540	37	29	16	M27
450	635	578	40	32	16	M30
500	700	635	43	32	20	M30
600	815	749	48	35	20	M33
<b>AWWA</b>						
700	927	864	33	35	28	M33
750	984	914	35	35	28	M33
800	1060	978	38	41	28	M39
900	1168	1086	41	41	32	M39
1000	1289	1200	41	41	36	M39
1050	1346	1257	45	41	36	M39
1100	1403	1315	45	41	40	M39
1200	1511	1422	48	41	44	M39

## B.1 Flange mating dimensions (metric)

DN mm	Dimensions (mm)				Bolting	
	D	PCD	T	B	Holes	Bolts
<b>AS 4087 PN16</b>						
50	150	114	20	18	4	M16
65	165	127	20	18	4	M16
80	185	146	20	18	4	M16
100	215	178	20	18	4	M16
150	280	235	23	18	8	M16
200	335	292	24	18	8	M16
250	405	356	30	22	8	M20
300	455	406	33	22	12	M20
350	525	470	30	26	12	M24
400	580	521	30	26	12	M24
450	640	584	30	26	12	M24
500	705	641	38	26	16	M24
600	825	756	48	30	16	M27
700	910	845	56	30	20	M27
800	1060	984	56	36	20	M33
900	1175	1092	66	36	24	M33
1000	1255	1175	66	36	24	M33
1200	1490	1410	76	36	32	M33
<b>K10</b>						
15	95	70	12	15	4	M12
25	125	90	16	19	4	M16
40	140	105	18	19	4	M16
50	155	120	20	19	4	M16
65	175	140	20	19	4	M16
80	185	150	20	19	8	M16
100	210	175	20	19	8	M16
125	250	210	22	23	8	M20
150	280	240	22	23	8	M20
200	330	290	22	23	12	M20
250	400	355	24	25	12	M22
300	445	400	24	25	16	M22
350	490	445	26	25	16	M22
400	560	510	28	27	16	M24
450	620	565	30	27	20	M24
500	675	620	30	27	20	M24
600	795	730	32	33	24	M30

## B.2 Coil resistance

Table B-2 Coil resistance [ $\Omega$ ]

DN	Inch	Resistance min.	Resistance max.
15	1/2	82	100
25	1	82	100
40	1 1/2	89	99
50	2	114.4	124.4
65	2 1/2	118	128
80	3	119	133
100	4	112	122
125	5	113	123
150	6	111	121
200	8	104	114
250	10	99	109
300	12	103	113
350	14	94	106
400	16	94	106
450	18	94	106
500	20	94	106
600	24	90	102
700	28	90	102
750	30	90	102
800	32	90	102
900	36	90	102
1000	40	82	94
1050	42	82	94
1100	44	82	94
1200	48	82	94

### Note

#### Reference values

- All resistance values are at 20 °C
- The resistance changes proportionally 0.4% / °C



# Glossary

## EMC

Electromagnetic compatibility (EMC) is the branch of electrical sciences which studies the unintentional generation, propagation and reception of electromagnetic energy with reference to the unwanted effects (Electromagnetic Interference, or EMI) that such energy may induce. The goal of EMC is the correct operation, in the same electromagnetic environment, of different equipment which use electromagnetic phenomena, and the avoidance of any interference effects.

## IP

An IP (Ingress Protection) number is used to specify the environmental protection of enclosures around electronic equipment. These ratings are determined by specific tests. The IP number is composed of two numbers, the first referring to the protection against solid objects and the second against liquids. The higher the number, the better the protection. For example, in IP67 the first Number (6) means that the device is totally protected against dust, and the second (7) that it is protected against the effect of immersion between 15cm and 1m

## LVD

Low voltage directive (LVD) is a directive from the European Commission (2014/35/EU) that ensures, that electrical equipment within certain voltage limits provides a high level of protection for European citizens, and benefits fully from the single market.

## PED

Pressure Equipment Directive (PED) is a directive from the European Commission (2014/68/EU) that applies to the design, manufacture and conformity assessment of stationary pressure equipment with a maximum allowable pressure greater than 0,5 bar.

## SENSORPROM

All sensor related settings/data saved on an EPROM. SENSORPROM technology automatically configures the transmitter at start up providing calibration data, pipe size, sensor type, and output settings. The SENSORPROM automatically stores values or settings changed by users, and automatically re-programs any new transmitter without loss of accuracy.



# Index

## A

Abrasive liquids, 21  
Applications, 13

## C

Cable specifications, 28, 48  
Catalog  
    catalog sheets, 59  
Cathodic protection, 25  
Certificates, 9, 59  
Coil insulation check, 43  
Coil resistance check, 43  
Customer Support, (Refer to Technical support)  
Customer Support Hotline, 39

## D

Dimensions, 54  
Direct burial, 38  
Disposal, 41  
Document history, 5  
Downloads, 59

## E

Electrical connection  
    Cable specifications, 28  
    Safety instructions, 27  
Electrode resistance check, 44  
Empty pipe detection, 21

## F

FAQ  
    Fluctuating process values, 44  
Flange mating dimensions, 61

## G

Gas / Air bubbles, 21

## H

Hazardous area  
    Laws and directives, 9  
Horizontal Pipes, 21  
Hotline, 39, (Refer to Support request)

## I

Inlet / outlet conditions, 19  
Installation  
    Horizontal Pipes, 21  
    in U-tube, 18  
    Indoor/outdoor, 17  
    Large pipes, 19  
    Location in system, 18  
    Mounting of sensor, 22  
    Partially filled pipes, 19  
    Pipes with free outlet, 18  
    Safety instructions, 17  
    Vertical pipes, 21  
Internet  
    Contact person, 40  
    Support, 39  
Items supplied, 6

## L

Laws and directives  
    Disassembly, 9  
    Personel, 9

## M

Mains supply, 27  
Maintenance, 39  
Manuals, 59  
Material compatibility, 10  
Measurement principle, 14  
Modifications  
    correct usage, 12  
    improper, 12  
Mounting, (See Installation)

## P

Potential equalization, 25  
Potting, 37  
Pressure  
    Safety instructions, 17  
Pressure Equipment Directive, 10  
Process fluid  
    Conductivity, 50  
Protective conductor terminal, 28  
Protective earth, 28

## R

Repair, 39  
Return procedure, 41

## S

Safety, 9  
    Instrument safety standards, 10  
    Sensor installation, 17  
Safety instructions  
    Electrical connection, 27  
Scope of delivery, 5  
Sensor check, 43  
Sensor orientation, 21  
Service, 39, 60  
Service and support  
    Internet, 60  
Support, 39, 60  
Support request, 60  
System components, 13

## T

Technical support, 60  
    partner, 60  
    personal contact, 60  
Test certificates, 9  
Theory of operation, 14  
Torques values, 23

## V

Vertical Pipes, 21  
Vibrations, 17

## W

Warranty, 7  
Weight, 56  
Wire insulation, 28