



ecoGEO+ HP R454B GEN1



EN

TECHNICAL MANUAL

MODEL:

SERVICE CONTACT:

Contents

1. General Information	5
1.1. Safety considerations	5
1.2. Disposal	12
2. Heat pump installation	13
2.1. Transport and handling	13
2.2. Dimensions and connections	13
2.3. Unpacking	14
2.4. Assembly and disassembly of the covers	14
2.5. Recommended positioning	16
2.6. Service areas	19
3. Hydraulic installation	20
3.1. General instructions	20
3.2. Source circuit	20
3.3. Heating / Cooling circuit	21
3.4. DHW circuit	24
3.5. Pool circuit	25
4. Filling and discharge circuits	27
4.1. Filling the production circuit (heating, cooling, DHW and pool)	27
4.2. Filling the source circuit	27
5. Electrical system	29
5.1. General instructions	29
5.2. Heat pump power supply	33
5.3. External protections	35
5.4. Outside temperature probe	35
5.5. External storage systems	35
5.6. External production equipment	36
5.7. Simultaneous production	36
5.8. DG1 – SG5 Outlet Units	36
5.9. External auxiliary equipment	37
5.10. Alarm signal	37
5.11. Remote services production control	38
5.12. Inside environment control	38
5.13. Remote control by BUS	40
5.14. Energy meter	41
5.15. R454B leak detector	42
6. Start-up	42
7. Technical specifications	43
7.1. Component location	43
7.2. Power circuit diagram	48
7.3. Electrical connection tables	49
7.4. Load losses	52
8. Operation map	53
9. Operation curves	54

9.1. Power and consumption curves.....54

9.2. HTR curves56

10. Technical data table..... 57

11. Symbols 60

1. General Information



- This manual contains the necessary information to install the heat pump. Read this manual carefully before installing the equipment. Keep this manual handy for future reference.

This manual contains two different kinds of warnings that should be heeded.



NOTE

- Indicates a situation that may cause material damage or malfunctioning of the equipment. May also be used to indicate practices which are recommended or not recommended for the equipment.



DANGER!

- **W**arning of imminent or potential danger which, if not avoided, may result in injury or even death. May also be used to warn of unsafe practices.

ecoGEO+ heat pumps are designed to function within heating systems, cooling systems, for the production of domestic hot water (DHW), pool heating or other similar uses. The manufacturer is not responsible for any material damage and/or personal injury resulting from improper use or incorrect installation of the equipment.

The heat pump must be installed by a licensed installer in accordance with applicable local regulations and in accordance with the installation instructions described in this manual.

1.1. Safety considerations

The detailed instructions in this section cover important aspects for your safety; as such they must be strictly complied with.



DANGER!

- **A**ll the installation and maintenance work described in this manual must be performed by an authorised engineer.
- **C**hildren shall not play with the heat pump.
- **C**leaning and user maintenance shall not be made by children without supervision.
- **I**mproper installation or use of the equipment could cause electrocution, short circuits, leakage of working fluids, fire or other personal injury and/or material damage.
- **I**f you are unsure of the procedures for installation, maintenance or use of the equipment, contact your local dealer or technical support for advice.
- **I**f you detect a malfunction in the unit, contact your local dealer or technical support to answer any questions.
- **W**hen carrying out installation, maintenance or commissioning of the heat pump, always use appropriate personal protective equipment.
- **K**eeep the plastic bags included in the packaging out of the reach of children, as they could result in injury through asphyxia.
- **T**he appliance shall be stored in a room without continuously operating ignition sources (for example: open flames, an operating gas appliance or an operating electric heater).

Refrigerant

Ecoforest heat pumps may contain different types of refrigerants depending on the model. The refrigerants used by Ecoforest are not harmful to the environment as they do not contain chlorine and therefore do not contribute to the destruction of the ozone layer. Refer to the label on your heat pump to identify which refrigerant it contains. You can use the following table to check their flammability and toxicity characteristics.

Refrigerant	GWP	Flammability, see label	
R454B	466	A2L	

Table 1.1. Flammability and toxicity properties of refrigerants used by Ecoforest heat pumps.

Under normal operation of the heat pump the toxicity of the refrigerant is nil and there is no risk of explosion. However, the following precautions should be taken in the event of refrigerant leakage.



- **T**he refrigerant contained inside the heat pump must not be released into the atmosphere as it contributes to global warming (GWP).
- **T**he refrigerant should be recovered for recycling or elimination according to current legislation.
- **D**o not directly touch the area where the leak has occurred, as this could result in severe frostbite injuries.
- **I**n the event of refrigerant leakage, ventilate the area immediately.
- **M**ake sure that the area in which the heat pump is installed is properly ventilated before you open the unit's refrigerant circuit.
- **K**ep the area ventilated while performing maintenance or repair operations.
- **A**nyone who has come into contact with refrigerant vapour must evacuate the area immediately and breathe fresh air.
- **A1** refrigerants: Direct exposure of the refrigerant to a flame produces toxic gas. However, this gas can be detected by its odour when at concentrations well below the permitted limits.
- **A2L** and **A3** refrigerants: Do not allow any source of ignition to come into contact with the refrigerant. When searching for a refrigerant leakage, use means that do not involve a naked flame. If you use an electronic detector, it must be designed to detect the refrigerant used by the unit. You can also use liquid detectors, but make sure that the detergents in these liquids do not contain Chlorine which can corrode copper piping. Please remember that refrigerants may not give off any odour.

In addition to the above recommendations, please observe the following precautions when carrying out maintenance and repair work.



DANGER!

- **B**efore carrying out any work on the refrigerant circuit, the power supply must be disconnected. If it is absolutely necessary to have an electrical supply to equipment during servicing, then a permanently operating form of leak detection shall be located at the most critical point to warn of a potentially hazardous situation.
- **D**o not pierce or burn any pipes that contain refrigerant until the equipment has been discharged.
- **D**o not carry out maintenance work in enclosed spaces. If necessary, switch off the heat pump and carry out repairs in an adjacent well-ventilated room.
- **A**ll maintenance work must be carried out by an authorised installer in accordance with the applicable local regulations governing work involving refrigerants, and with the instructions contained in this manual. In addition, everyone involved in maintenance work must be aware of the hazards associated with working with refrigerants.
- **F**ollow the maintenance and service guidelines in this manual at all times. If in doubt, contact Ecoforest's technical department for assistance.
- **T**he work area must be checked with a refrigerant detector, appropriate to each type of refrigerant, before and during any tasks that require the use of a flame or any other form of heat input to avoid creating explosive atmospheres. To ensure that the gas concentration is a maximum of 25% of the lowest combustible concentration (Lower Flammability Limit, LFL) of the refrigerant used, the leakage detection equipment must be configured and calibrated for the refrigerant used.
- **N**o one carrying out work on a refrigeration system that involves exposing piping should use any source of ignition in such a way as to create a risk of fire or explosion.
- **M**ake sure that CO₂ extinguishing equipment is on hand before starting work involving heat input.
- **C**heck that there are no sources of ignition, including cigarettes, while performing maintenance and repair work on the equipment.
- **B**efore any work is carried out, you must inspect the area around the equipment to ensure that there are no flammable hazards or any risk of ignition. "No smoking" signs shall be put in place.
- **I**f you suspect a leak, all naked flames must be eliminated / extinguished.
- **I**f you discover a refrigerant leak requiring soldering, all refrigerant must be recovered from the system. Do not apply a flame until the circuit is completely empty.
- **M**ake sure that any replacement components in the refrigerant circuit or the heat pump are supplied or approved by Ecoforest. Other parts may result in the ignition of refrigerant in the atmosphere from a leak.
- **D**o not apply any permanent inductive or capacitive charge to the heat pump.



DANGER!

- In the presence of a flammable atmosphere, do not activate any component of the heat pump.
- If there is a problem that might compromise safety, do not connect the heat pump to any power supply until it has been satisfactorily resolved. If the problem cannot be corrected immediately, but it is nonetheless necessary to continue with the operation, a suitable temporary solution, agreed with Ecoforest's technical department, must be used. This must be reported to the owner of the equipment so that all parties can be informed.
- Never modify safety features such as pressure switches or refrigerant circuit sensors.
- Make sure that the recovery and vacuum equipment is suitable for working with the refrigerant used in the unit, and that it is in good condition.
- At the end of the repair, leave all components (insulation, fasteners and cables) in the same condition as when you found them. In the event of any damage, replace the element in question.
- When starting up the unit, make sure that the condensers are discharged: do this in a safe manner to avoid the possibility of causing sparks.
- Make sure that no active electrical wiring or components are left exposed while charging, recovering, or pumping out the system.
- Make sure that grounding continuity is maintained throughout maintenance and repair work.
- Particular attention shall be paid to the following to ensure that by working on electrical components, the casing is not altered in such a way that the level of protection is affected. This shall include damage to cables, excessive number of connections, terminals not made to original specification, damage to seals, incorrect fitting of glands, etc.
- Intrinsically safe components are the only types that can be worked on while live in the presence of a flammable atmosphere. The test apparatus shall be at the correct rating.

When performing work on a refrigerant circuit, follow these brief guidelines:

1. Remove the refrigerant following local and national regulations.
2. Pump out the unit (vacuum).
3. Purge with Nitrogen (N₂).
4. Pump out the unit (vacuum).
5. Purge the circuit and spray the area where the opening is to be carried out with Nitrogen (N₂).
6. Open the circuit with a blowtorch or by cutting.
7. Carry out the repair work.
8. Close and pressurize with Nitrogen (N₂) to check for the presence of leaks.
9. Pump out the unit.
10. Fill it with the amount of refrigerant indicated on the product label.

Observe the following warnings during the recovery and charging processes:



- **W**hen transferring refrigerant to recovery cylinders, make sure that only suitable refrigerant recovery cylinders are used. Make sure that the correct number of cylinders are available to hold the total system charge. All cylinders to be used are designed for the refrigerant being recovered and labelled for that refrigerant (i.e., special refrigerant recovery cylinders). Cylinders must be complete with a pressure relief valve and associated cut-off valves in good working order. Empty recovery cylinders should be evacuated and, if possible, cooled before recovery takes place.
- **T**he recovery equipment must be in good working order and a set of instructions for the equipment must be to hand. It must be suitable for the recovery of all appropriate refrigerants, including, where applicable, flammable refrigerants. A set of calibrated scales must also be available and in good working order. Hoses must be complete with disconnect couplings free of leaks and in good condition. Before using the recovery machine, check that it is in good working order, that it has been properly maintained and that all associated electrical components are sealed to prevent ignition in the event of refrigerant being released. If in doubt, ask the manufacturer.
- **T**he recovered refrigerant shall be returned to the refrigerant supplier in the correct recovery canister and an appropriate waste transfer note shall be provided. Do not mix refrigerants in recovery units and particularly not in recovery cylinders.
- **I**f you are going to remove a compressor or compressor oil, make sure that it has been evacuated to an acceptable level to ensure that no flammable refrigerant remains within the lubricant. Evacuate the compressor before you return it to the suppliers. To speed up this process, only heat the compressor body by electrical means. When draining oil from a system, do so in a safe manner.
- **M**ake sure that the different refrigerants are not contaminated when using the charging equipment. Keep hoses or lines as short as possible to minimize the amount of refrigerant they contain.
- **K**eep the recovery tanks in an appropriate position as per the instructions.
- **T**he heat pump shall be purged with oxygen-free nitrogen to render the appliance safe for flammable refrigerants. This process must be repeated several times. Compressed air or oxygen shall not be used for purging refrigerant systems.
- **T**he purging shall be achieved by breaking the vacuum in the system with oxygen-free nitrogen and continuing to fill until the working pressure is achieved, then venting to atmosphere, and finally pulling down to a vacuum. This process shall be repeated until no refrigerant is within the system. When the final oxygen-free nitrogen charge is used, the system shall be vented down to atmospheric pressure to enable work to take place.
- **T**he outlet for the vacuum pump shall not be close to any potential ignition sources, and ventilation shall be available.
- **M**ake sure that the refrigeration system is grounded before charging the system with refrigerant.
- **T**ake great care not to overfill the refrigeration system.



DANGER!

- The system must be tested for leaks when charging has been completed but before start-up. A leak test should be carried out before the equipment is left to operate normally.
- Sealed electrical and intrinsically safe components must be replaced when broken or faulty.

Hydraulic installation

Installation and subsequent interventions on the heating, brine or DHW circuits must only be performed by authorised personnel in accordance with applicable local regulations and the instructions provided in this manual.



DANGER!

- Do not touch any of the internal components during or immediately after heat pump operation; this can result in burns caused by cold or heat. If these components need to be touched, allow sufficient time for the temperatures to stabilize and wear protective gloves to avoid injury.
- Do not install automatic traps out of the technical room. All of them must be placed within this enclosure.

Water quality

Be aware of how the DHW circuits and tank of the heat pump react to corrosion. If you are not sure about the quality of the water available for filling the system, analyze it. In the following tables you can check the water quality level requirements for the production and source circuit.

Water components	Concentration in mg/l	Water components	Concentration in mg/l
Alkalinity	$\text{HCO}_3^- < 70$	Free carbon dioxide	$\text{CO}_2 < 5$
Sulphur	$\text{SO}_4^{2-} < 70$	Nitrate	$\text{NO}_3^- < 100$
Alkalinity / Sulphur	$\text{HCO}_3^- / \text{SO}_4^{2-} > 1$	Iron	$\text{Fe} < 0.2$
Ammonium	$\text{NH}_4 < 2$	Aluminium	$\text{Al} < 0.2$
Free chlorine	$\text{Cl}_2 < 1$	Manganese	$\text{Mn} < 0.1$
Hydrogen sulphur	$\text{H}_2\text{S} < 0.05$	Chloride	$\text{Cl}^- < 300$

Table 1.2. Concentration limits of water elements for production and source circuits.

Water properties	Limit values
pH	$7.5 < \text{pH} < 9$
Hardness	$4 < \text{°dH} < 8.5$
Electrical conductivity	$10 < \mu\text{S/cm} < 500$

Table 1.3. Water property limits for production and source circuits.



DANGER!

- Risk of damage due to unsuitable water.
- Deposits caused using unsuitable water can damage the source source, the pipes, the heat exchangers and the DHW tank of the heat pump.
- The use of sea water is not permitted.
- The quality of the drinking water must comply with the applicable regional regulations and the instructions in this manual.

Electrical system

Any intervention on the electrical system must only be performed by an authorised electrician in accordance with applicable local regulations and the instructions provided in this manual.



DANGER!

-
- Remember that the heat pump has multiple external power supply.
 - The heat pump must be supplied with an external switch that can shut off all the circuits. Ecoforest recommend installing one external automatic breaker in each external power supply that provide full disconnection under overvoltage category III (control, internal auxiliary equipment and drive).
 - Before performing any operation on the electrical panel, disconnect the power supply.
 - During installation and maintenance of the equipment never leave the electrical panel unattended while it is exposed.
 - Do not touch any component of the electrical panel with wet hands as this could cause an electric shock.
 - Install cables entering the heat pump in such a way that they have no voltage, cannot become corroded, are not affected by vibration and do not touch sharp edges. During repairs or overhauls check for effects of aging or continuous vibration from sources such as the compressor.
 - This unit is equipped with electrically powered safety measures. To be effective, the unit must be electrically powered at all times after installation, other than when servicing.
 - Leak detection system installed. Unit must be powered except for service.
 - Risk of electric shock. Can cause injury or death: System contains oversize protective earthing (grounding) terminal which shall be properly connected.
-

1.2. Disposal



- This device should not be treated as household waste.
- At the end of its useful life, dispose of the device properly in accordance with local regulations and in an environmentally friendly way.

The heat pump contains refrigerant. Ecoforest uses refrigerants that are not harmful to the environment, but once their useful life cycle is over, the refrigerant must be recovered so that it can be recycled or disposed of in accordance with current regulations.

Please read the following warnings carefully before disposal.



DANGER!

- **F**amiliarize yourself with the equipment and its use.
- **E**lectrically isolate the system.
- **B**efore you begin the procedure, make sure that you have the necessary mechanical equipment to handle the refrigerant tank. Also make sure that all necessary personal safety equipment is available and used properly. Finally, make sure that the recovery process is continuously supervised by an authorised person and that the recovery equipment and tanks comply with the appropriate standards.
- **P**ump out the refrigerant system, if possible. If it is not possible to pump it out, create a branch so that the refrigerant can be recovered from different parts of the system.
- **C**heck that the refrigerant tank is on the scale before you start to recover it. Start up the recovery device and recover according to the manufacturer's instructions.
- **D**o not overfill the cylinders (max. 80% of liquid content volume).
- **D**o not exceed the maximum permissible working pressure of the cylinders, even temporarily.
- **W**hen the cylinders have been correctly filled and the process is complete, close all cut-off valves on the equipment and remove the cylinders and equipment from the installation immediately.
- **T**he recovered refrigerant must not be poured into any other system before it has been cleaned and inspected.
- **T**he equipment must be marked to indicate that it has been taken out of operation and emptied of refrigerant. The marking must be dated and signed. Check that the equipment is marked to indicate that it contains flammable refrigerant.

2. Heat pump installation

2.1. Transport and handling

The heat pump must be transported vertically and not exposed to adverse weather conditions. It can be lain carefully on its rear side to facilitate transportation to the installation site.



NOTE

- Do not tilt the heat pump more than 45° since this could impair proper equipment operation.
- Due to its heavy weight, the heat pump should be handled by two workers using a forklift for heavy loads.

2.2. Dimensions and connections

The overall dimensions and hydraulic connections of the ecoGEO+ HP heat pumps are described below.

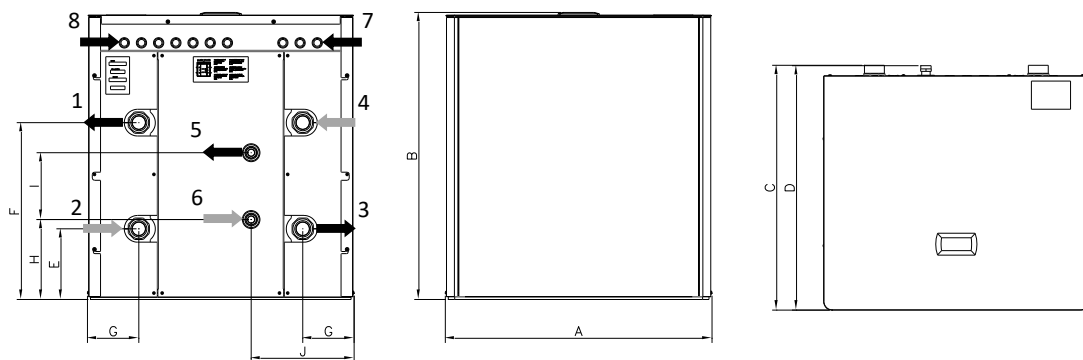

Figure 2.1. Overall dimensions and hydraulic connections of the ecoGEO+ HP models.

No	ecoGEO+ HP1	ecoGEO+ HP3	ecoGEO+ HP 400/575 170 R454B
1	Heating supply / heat dissipation	Heating / cooling supply	G2-1/2" Male
2	Heating return / heat dissipation	Heating / cooling return	G2-1/2" Male
3	Source / cooling supply	Source supply / heat dissipation	G2-1/2" Male
4	Source /cooling return	Source return / heat dissipation	G2-1/2" Male
5	HTR supply		G1-1/4" Male
6	HTR return		G1-1/4" Male
7	Power cables inlet		
8	Control cables inlet		

Table 2.1. Overall hydraulic connections of the ecoGEO+ HP.

No.	ecoGEO+ HP 400/575 170 R454B
A	1009
B	1074
C	916
D	914
E	265
F	662
G	195
H	299
I	250
J	389

Table 2.2. Key to overall dimensions in mm.

2.3. Unpacking

To unpack the heat pump, remove the wooden box carefully, remove the pallet anchoring screws and perform a check to make sure the heat pump has not been damaged during transportation.

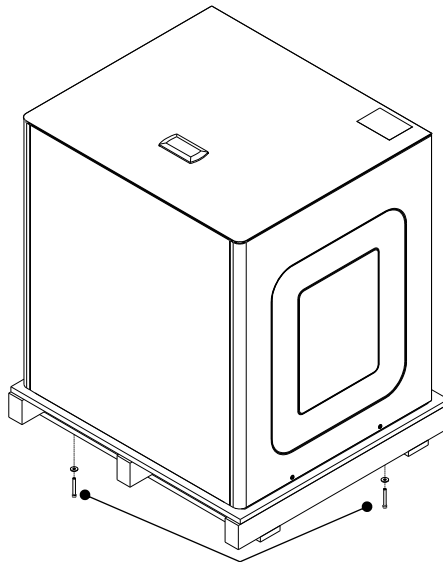

Anchoring studs to the pallet

Figure 2.2. Removing the screws fastening the heat pump to the pallet.

2.4. Assembly and disassembly of the covers

A 4 mm allen wrench is needed to assemble and disassemble the covers.

ecoGEO+ HP Models

1. Disassemble the top front cover. Remove the front and top screws. Pull the cover upwards.
2. Disassemble the bottom front cover. Remove the screws located at the upper part and pull upwards.
3. Disassemble the side covers. Remove the fastening screws and remove the cover.

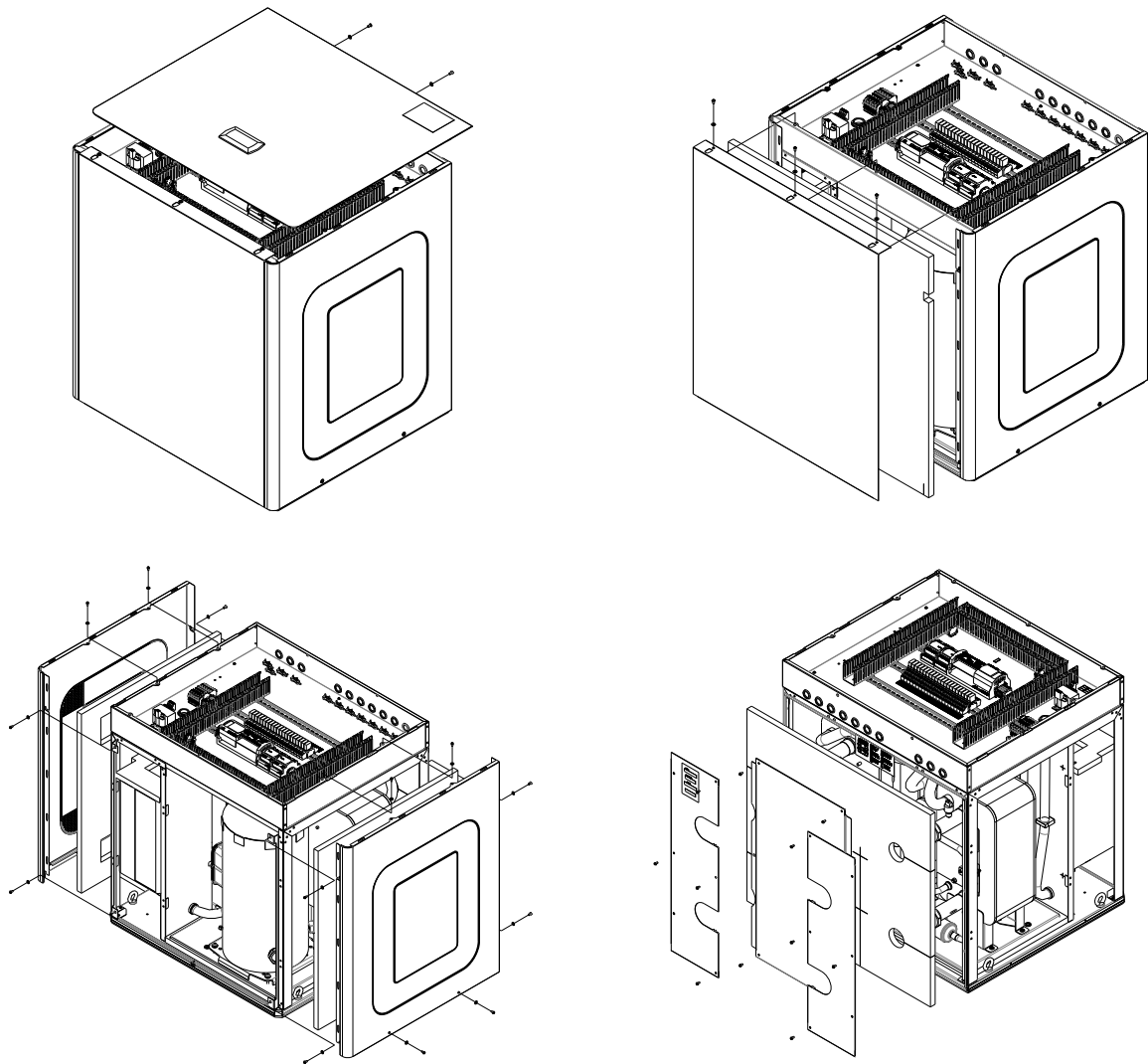

Figure 2.3. Disassembly of the covers of the ecoGEO+ HP models.



NOTE

- During cover disassembly, take care to remove the control panel cable without damaging it.

2.5. Recommended positioning



DANGER!

- The ecoGEO HP heat pumps range must be installed in a place where they are not accessible to the general public.

Choose a dry place where there is no risk of frost. Avoid installation against bedroom walls or walls of other rooms where noise emissions can be annoying. If possible, install the heat pump with the rear part pointed toward an exterior wall. Avoid installation near a corner since this can amplify noise emission levels.

The heat pump should be installed on a stable base that can support the total weight of the equipment and the operating fluids in its interior.

The available options for heat pump installation are:

ISO5149 or ANSI/ASHRAE 15 (USA) or CSA B52 (Canada) technical room

For the European market, installation in a technical room must comply with ISO 5149-3:2014, clause 5 and ISO 5149-3:2014/AMD1:2021, 5.13, 5.14 and 5.15.

For the North American market, installation in a technical room must comply with ANSI/ASHRAE 15 (USA) or CSA B52 (Canada) standards.

Natural ventilation of the machine room

Add two openings to the outside in the technical room where the heat pump is located. The two openings must have a minimum surface area of 0.15m². At least 50% of the surface area must be in the lower opening. The following image shows the specific location of the openings in the room in relation to the evacuation opening of the heat pump housing.

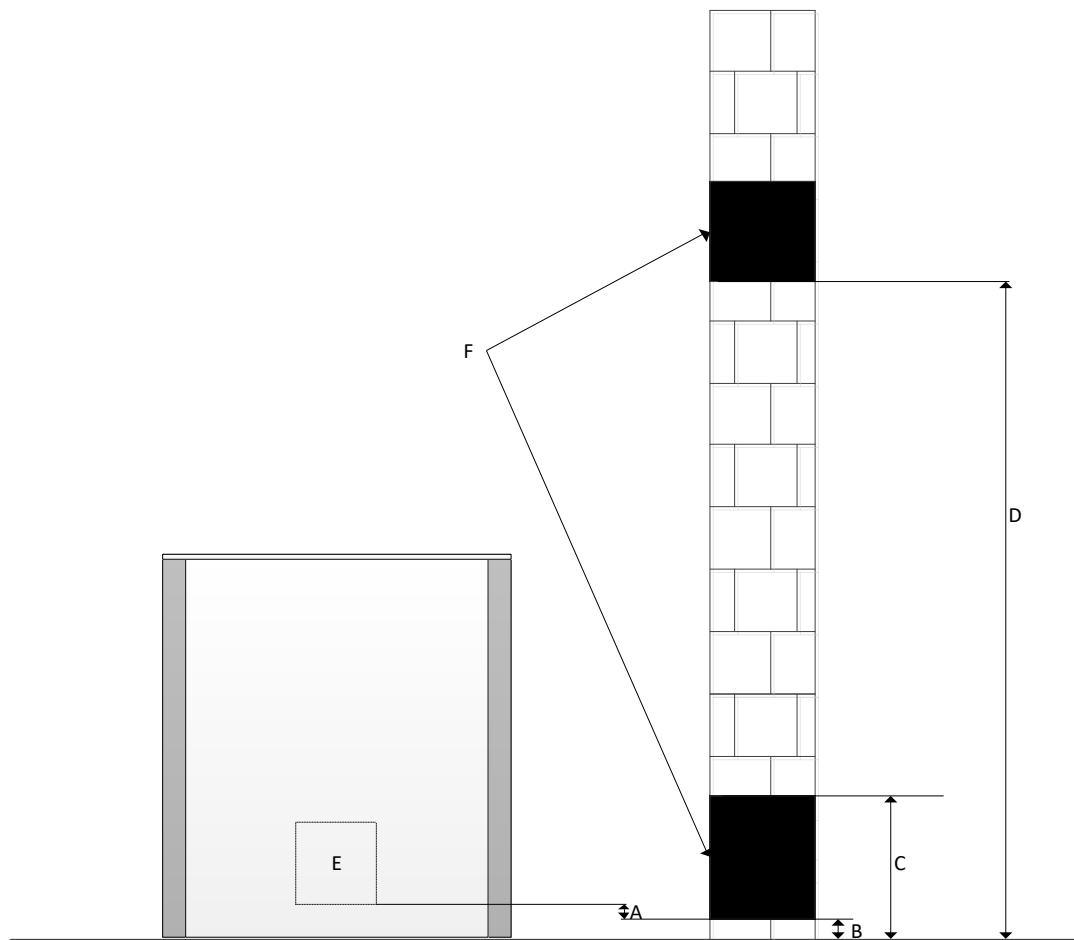

Figure 2.4. Diagrams for positioning the ventilation inlets to the outside of the machine room.

No	Description	Distances (mm)
A	Minimum distance from the lower ventilation of the technical room to the evacuation in the heat pump.	> 0
B	Minimum height of the lower ventilation of the technical room to the floor.	20 - 100
C	Maximum height of the lower ventilation of the technical room to the floor	200
D	Minimum height of the lower ventilation of the technical room to the floor.	1500
E	Gas evacuation opening of the heat pump	-
F	Openings in the machine room wall	-

Table 2.3. Dimensions for positioning the ventilation inlets outside the machine room.

Below is an example of the dimensions of the holes that must be opened in the wall to comply with the specifications of the standard. It would be applied in two identical holes, one above and one below, to divide the surface in both, 0.75 m² each.

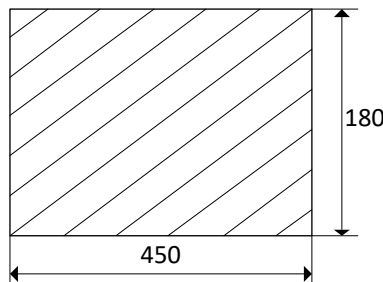

Figure 2.5. Dimensions of openings for natural ventilation in (dimensions in mm).

Mechanical ventilation of machine room

Installation of heat pump in machine room with mechanical ventilation, for this it must comply with the specifications detailed below.

- You must select a fan suitable for working with flammable gases. The minimum flow rate that the fan must provide is that reflected in the following graph. Consider the pressure losses of the evacuation pipe when selecting the fan.

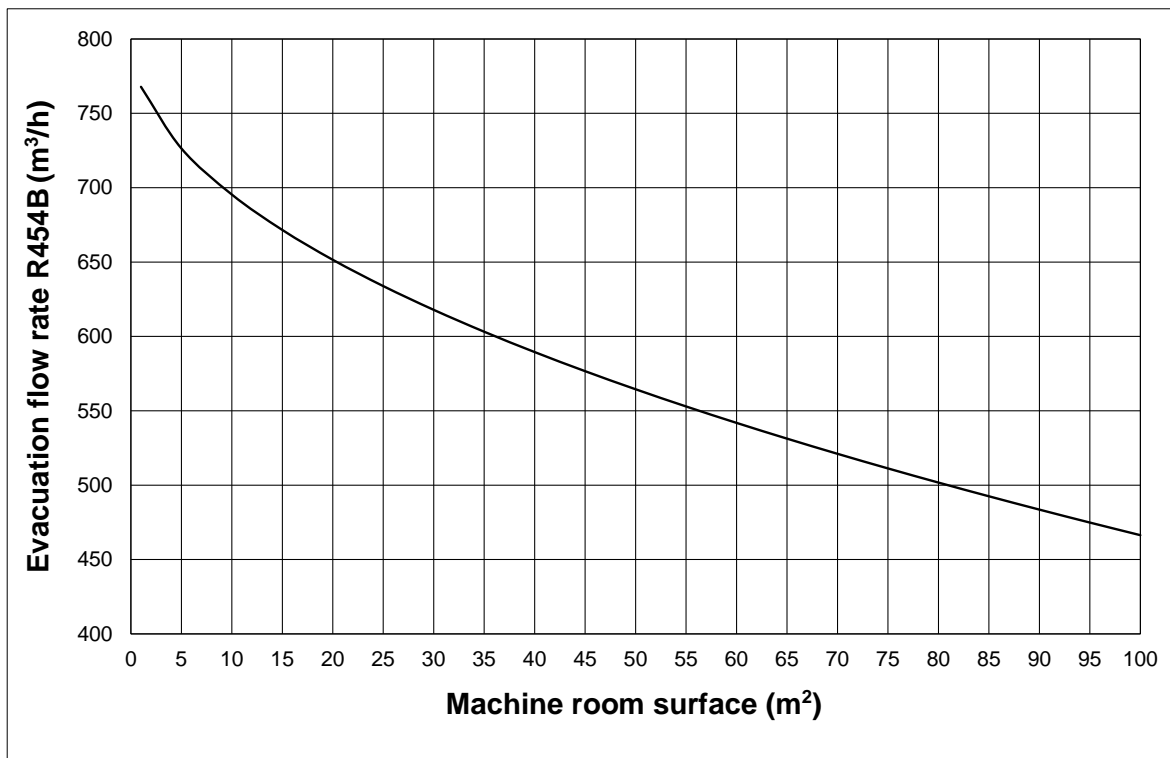

Figure 2.6. Dimensions of openings for natural ventilation in (dimensions in mm). Minimum R454B evacuation flow rate depending on the surface of the machine room.

- For mechanical ventilation, the lower edge of the openings that extract air from the machine room must not be more than 100 mm above the floor. The R454B refrigerant has a higher density than air, so an opening must be installed above the evacuation, so that fresh air enters and mixes with the refrigerant evacuated from the unit. Evacuated refrigerant backflows into the machine room must be avoided.
- The fan can be activated in two different ways: continuous activation or by means of a leak detector.

Continuous activation

The fan is continuously activated, except for maintenance operations. The flow rate must be checked and if the flow rate is detected for 10 seconds below the calculated minimum, an alert must be triggered to warn of the problem in the technical room and the operation of the heat pump must be stopped immediately (this can be done with the external safety input ESS, chapter 5.3).

Activation by leak detector

The other way is to activate the fan via an R454B leak detector, which activates the fan continuously during the detection of the leak and for at least 5 minutes after the detector stops detecting refrigerant in the room. During the time that the fan is activated, the operation of the heat pump must be prevented (this can be done with the external safety input ESS, chapter 5.3).

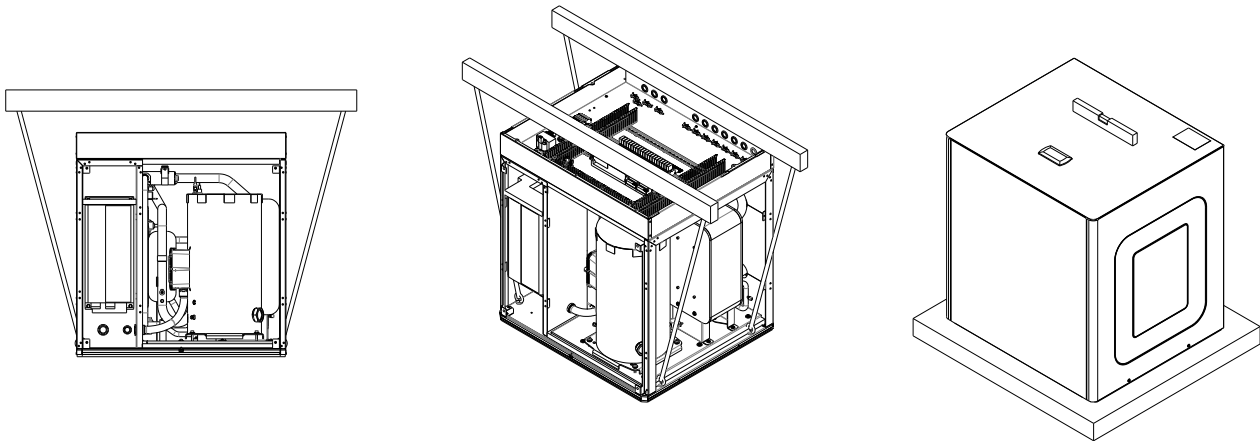

Figure 2.7. Positioning and levelling the heat pump.



NOTA

- Use the eyebolts provided with the heat pump to move the equipment to its destination.



DANGER!

- **A**dvertising: The ecoGEO+ heat pumps are IP20. This means its installation in high humidity conditions (laundries, saunas, ...) is forbidden.
- **U**se some element, such as a metal bar, to prevent slings or ropes from crushing the electrical panel, causing damage to people or equipment.

2.6. Service areas

The minimum recommended distances to be left around the heat pump to facilitate installation, start-up and maintenance work are indicated below.

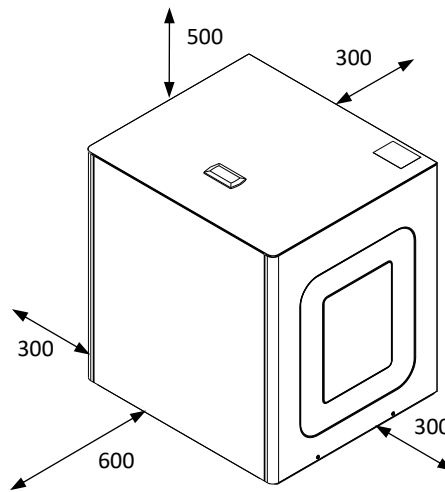

Figure 2.8. Minimum recommended service areas around the heat pump (amounts in mm).



- Do not cover the ventilation ducts of the heat pumps, there may be a risk of components breaking and causing injury and/or material damage.



- Pay special attention, both when designing the piping layout and when positioning the heat pump, to allow easy access to the cover hardware and convenient access to the internal components of the heat pump.

3. Hydraulic installation



NOTE

- The installation schemes included from here on should be considered simply as a guide.
- The design of the hydraulic installation must be performed by qualified personnel and in accordance with applicable local regulations.
- The design of the hydraulic system must always ensure the minimum required flow through the heat pump, otherwise, could cause malfunction of the equipment and even rupture.

3.1. General instructions

The following recommendations should be taken into consideration for proper hydraulic installation.

- Avoid excessive strain between the pipes and the heat pump connections to prevent leaks and/or transmission of vibrations. Flexible hoses should be used for heat pump connections.
- Install cut-off valves at all the hydraulic connections to facilitate future maintenance tasks.
- Install traps at all the installation points where air pockets can form.
- Place heat insulation on all circuit pipes to prevent unnecessary heat loss. Pay special attention to the heating insulation on the source circuit pipes, since these can reach temperatures below 0°C, causing condensation and/or frost.



DANGER!

- During installation work on the hydraulic circuits, take exceptional care to prevent liquid from spilling on the internal electrical heat pump components, which could cause personal injury due to electrocution and/or poor equipment operation.
- Do not install components that might cover the inlet or outlet of the safety valves; this could lead to a risk of some of its components breaking and cause injuries and/or material damage.
- Do not install automatic traps out of the technical room. All of them must be placed within this enclosure.

3.2. Source circuit

The ecoGEO+ heat pumps can be used with horizontal or vertical (A) geothermal source systems or by using groundwater (B).



DANGER!

- Carefully check the antifreeze concentration of the working fluid. Do not use automatic fill valves or other items that can change the concentration of the working fluid. Inadequate concentration of the working fluid could cause malfunction of the equipment and even rupture.

Geothermal source systems

Source systems with more than one circuit must be connected in parallel, so the flow rate through each one is similar.

Groundwater source systems

Groundwater source systems must use a midway exchanger to prevent the heat pump evaporator from corrosion, freezing or getting dirty.

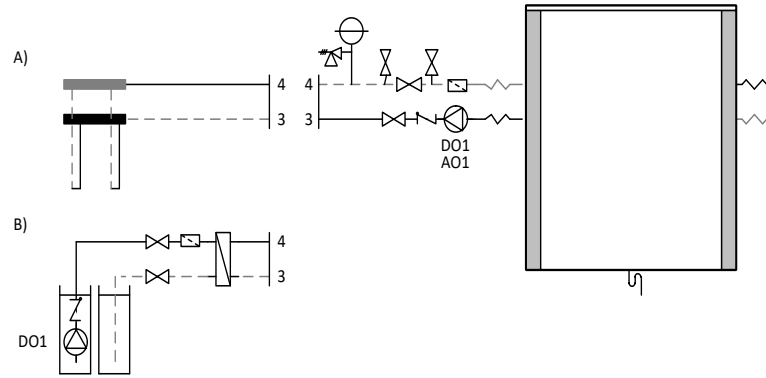

Figure 3.1. Source circuit connection options.

Installation instructions

Follow the instructions below to wire the source circuit.

- Install the necessary components to carry out the filling/discharge of the return pipe.
- Install a particulate filter in the return pipe with a mesh size no greater than 1 mm. It is recommended to install shut off valves immediately before and after the filter to make it easier to clean or replace.
- Install a safety unit (expansion vessel + safety valve) in the suction part of the circulator pump to protect the circuit from overpressure.
- Adjust the pressure of the expansion vessel to make sure that the circuit remains pressurized at all points.
- Source circuit pressure should be between 0,7 and 10 bar (pressure gauge) (70 and 1000 kPa).
- Use a working fluid with a freezing point of at least 10°C below the minimum nominal working temperature of the equipment.
- Configure the equipment with a protection of at least 5°C above the freezing temperature of the working fluid.

3.3. Heating / Cooling circuit

The ecoGEO+ HP heat pumps can be connected to several types of heating / cooling systems, both directly and by separating buffer storage tanks. On the other hand, these enable control over several devices that are external to the heating / cooling system directly from the heat pump's electrical panel.

Heating / cooling system

The ecoGEO+ HP heat pumps are designed to be used with heating systems with nominal outlet temperatures of up to 55°C, such as underfloor heating systems, low temperature radiators or convectors. They are not recommended for use in heating systems that require higher temperatures.

The ecoGEO+ HP heat pumps can be used with cooling systems with nominal outlet temperatures of up to 7°C, such as convectors and underfloor cooling systems.

Exceptional care should be taken in the design and control in installations with underfloor cooling, to prevent problems of condensation on floors.

All the models allow control over external passive cooling units.

Direct installation

In simple heating / cooling systems, ecoGEO+ HP heat pumps can be installed directly into the distribution system, in systems with underfloor heating, low temperature radiators and convectors.

This configuration makes it possible to simplify the hydraulic installation, reduce costs and space, while optimizing the energy efficiency of the equipment. However, the design of the hydraulic installation must always guarantee the minimum required flow through the heat pump. For this, the necessary elements must be planned to protect the heat pump in the event of a low flow

situation in the emission system. For this, the installation can be planned to operate with at least one of the emission circuits open continuously. If all the emission circuits can be closed, it is recommended to install a differential pressure valve between the outlet and inlet pipes of the heat pump. Other solutions can also be considered, such as the installation of a hydraulic separator between the heat pump and the emission system, as long as the minimum required flow is guaranteed (see section 10).

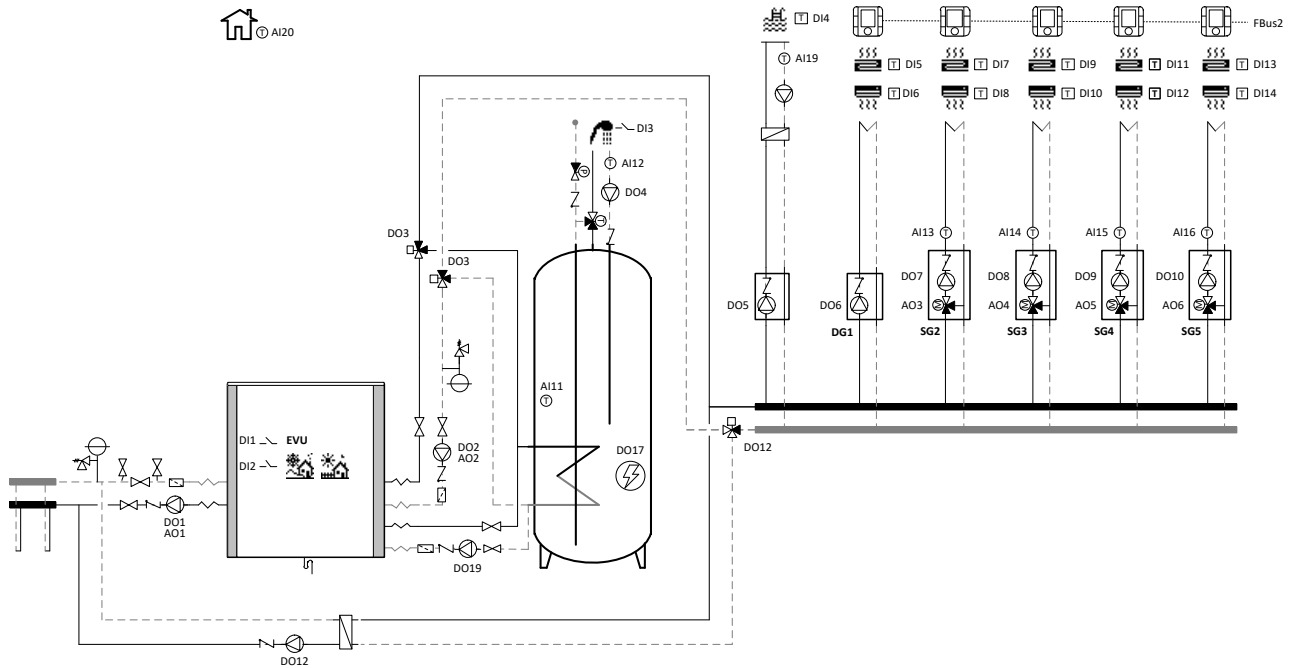

Figure 3.2. Wiring scheme directly to the heating / cooling system (ecoGEO+ HP3 models).

Installation using buffer storage tanks

If required by the application, the heat pump can also be connected to the heating / cooling system using a buffer separator tank. To do so, it is equipped with two temperature probes that are used to control a buffer storage tank for heating and a buffer storage tank for cooling. In installations where there is only one buffer storage tank for heating and cooling, both probes have to be installed in the storage tank. Install the temperature probes at the points where heating / cooling production begins. Heating / cooling production is stopped by the return temperature probe installed inside the heat pump.

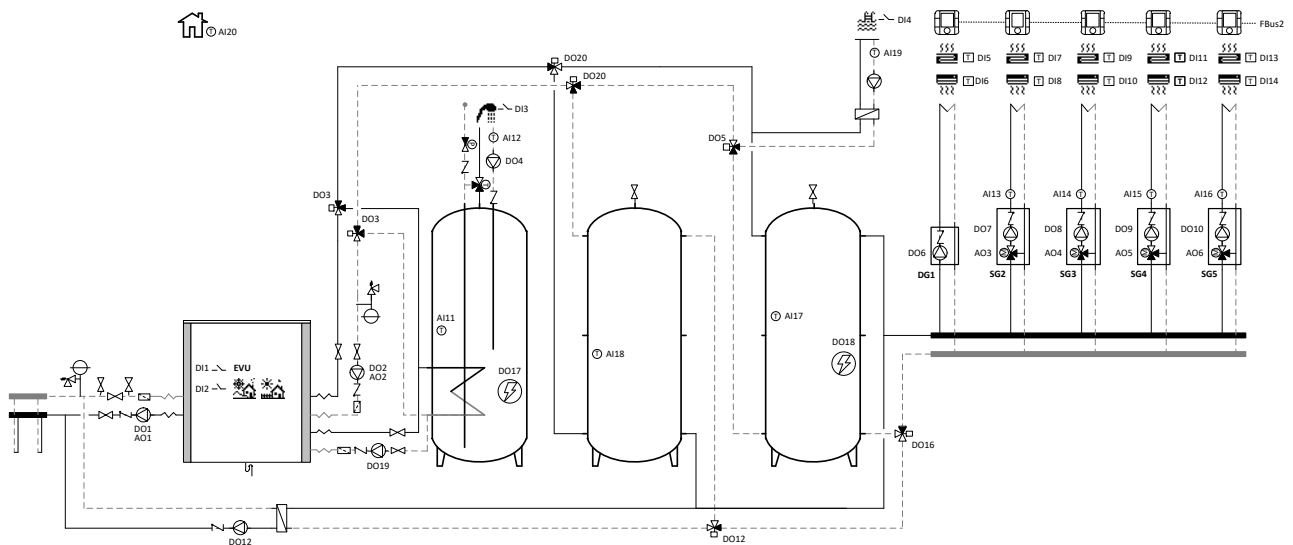

Figure 3.3. Wiring scheme using two buffer storage tanks (ecoGEO+ HP3 models).

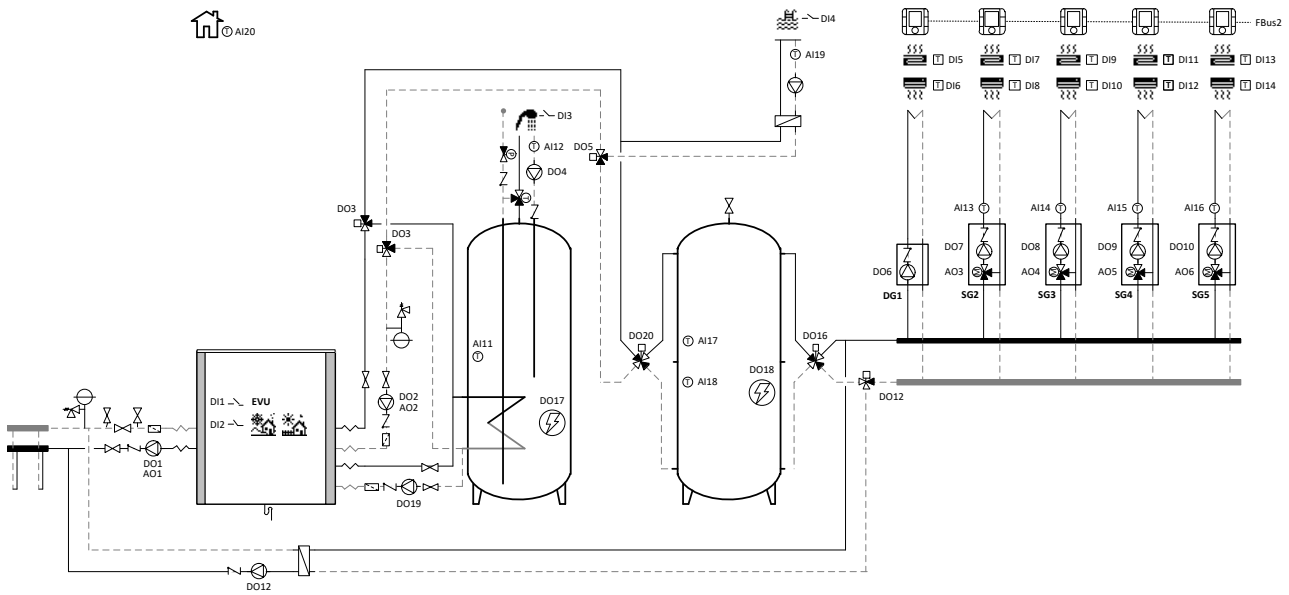

Figure 3.4. Wiring scheme using one buffer storage tanks (ecoGEO+ HP3 models).

Outlet units

These can manage as many as five different outlet temperatures. This is done by managing one direct outlet unit and four combined outlet units. The combined outlet units have to use modulating 3-way valves with an analogue signal of 0-10Vdc. Each outlet unit has independent terminals for heating and cooling demands. These signals are supplied with 24Vac voltage.

Auxiliary equipment integrated in the heating buffer storage tank

This is used to control an auxiliary unit integrated in the heating buffer storage tank. It can be used for normal heat production or as emergency equipment.

Auxiliary boiler

This is used to control start-up / stop of an auxiliary boiler and regulate final temperature downstream from the boiler by a 0-10 Vdc modulating 3-way valve. The heat pump can use the boiler to assist in normal heat production or as emergency equipment.



NOTE

- The hydraulic installation must ensure that while the boiler is operation, the temperature through the heat pump never exceeds 65°C, since this could cause severe damage to the refrigerant circuit.

Simultaneous production

This is used to control systems that product heat and cold simultaneously. In these types of installations, the heat pump moves energy from the cold production system to the various heat production systems and controls both the hot and cold outlet temperature. On the other hand, it uses modulating valves to detour part of the cold or heat production to the source system, there by maintaining the energy balance.

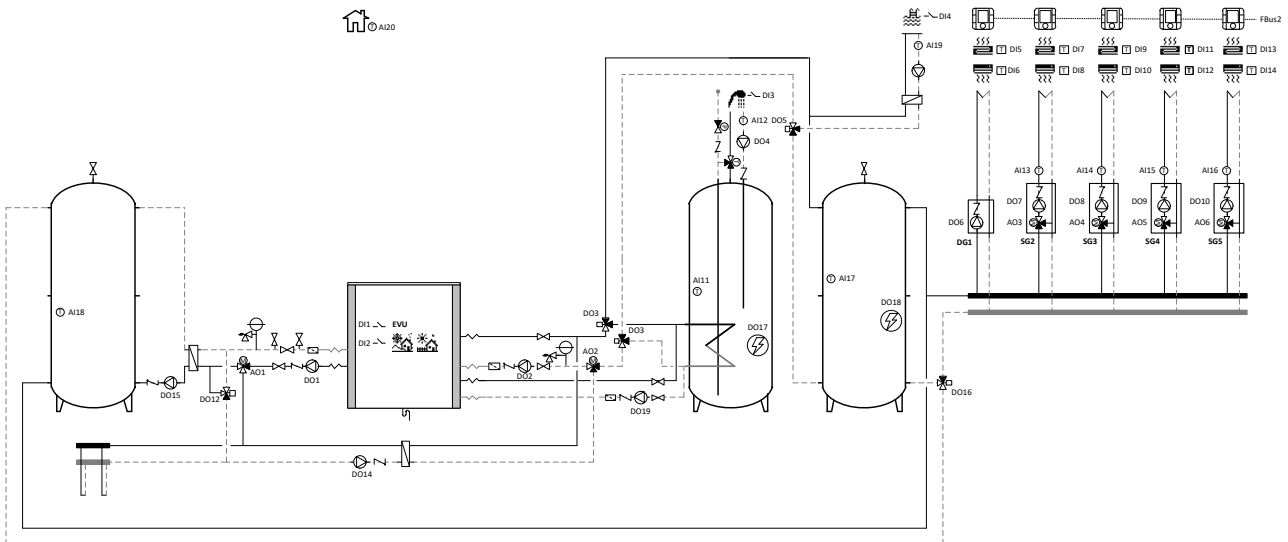

Figure 3.5. Wiring scheme using two buffer storage tanks with simultaneous production (ecoGEO+ HP1 models).

Installation instructions

Follow the instructions below to connect the heating / cooling circuit.

- Install a particulate filter in the return pipe with a mesh size no greater than 1 mm. It is recommended to install shut off valves immediately before and after the filter to make it easier to clean or replace.
- Check that the volume of the expansion vessel integrated in the heat pump is capable of absorbing any overpressures from the circuit. If this volume is not enough, install a supplementary external expansion vessel.
- If necessary, adjust the pressure of the expansion vessel integrated in the heat pump to guarantee that the circuit remains pressurized at all points.
- If there is an auxiliary system integrated in the heating storage tank, install a safety valve to protect it from any overpressures.
- Heating / cooling circuit pressure should be between 0,7 and 10 bar (pressure gauge) (70 and 1000 kPa).

3.4. DHW circuit

The ecoGEO+ HP heat pumps are designed to be used with external storage systems with a midway heat exchanger that can be either internal or external.

Connection to the heating circuit (A)

In models that are not equipped with the HTR system, DHW production should be connected to the heating circuit via an open / close 3-way valve. This type of connection allows non-simultaneous production for the DHW on the one hand and heating or cooling on the other hand.

Connection to the HTR system (B)

In addition to the option mentioned above, DHW production can be connected to the HTR circuit. This allows simultaneous heating / cooling and DHW production through the HTR system.

DHW Recirculation

This is used to control a DHW recirculation pump. If an external storage tank without a separate inlet for DHW recirculation is used, it is recommended to connect recirculation to the cold-water inlet pipe.

Auxiliary equipment integrated in the DHW storage tank

This is used to control a support system integrated in the DHW storage tank. This can be used as support to reach higher temperatures during normal production, to carry out legionella protection programs or as emergency equipment.

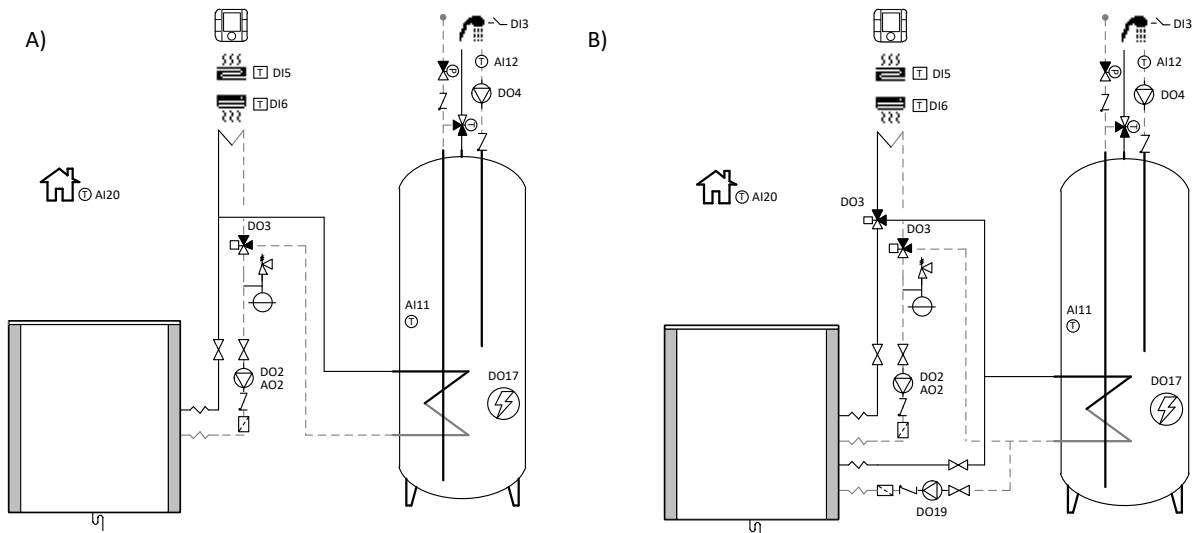

Figure 3.6. Wiring scheme of the DHW circuit

Installation instructions

Follow the instructions below to wire the DHW circuit.

- In the ecoGEO+ HP models, install a particulate filter in the return pipe to the heat pump with a mesh size no greater than 1 mm. It is recommended to install cut-off valves immediately before and after the filter to make it easier to clean or replace.
- The DHW tank is permanently connected to the tap water supply.
- Install a check valve at the tap water inlet to prevent the possible return of hot water from the mains.
- A safety group (expansion vessel + safety valve) must be installed at the tap water inlet to prevent possible overpressure in the DHW storage tank.
- If there is a risk of scalding, a thermostatic mixing valve should be installed at the DHW outlet.
- If the maximum system pressure can exceed 5 bar, it is recommended to install a pressure reducing valve in the mains inlet to prevent overpressure in the storage tank.
- If there is an auxiliary system integrated in the DHW storage tank, install a safety valve in the production circuit inlet to protect it from any overpressures.

3.5. Pool circuit

The ecoGEO+ heat pumps can be used to send hot water directly to the pool production storage tank through an open / close 3-way valve. It can be connected two different ways for this purpose, depending on the application. In both cases, the POOL mode must be activated via a voltage-free signal from a thermostat.

Connection to the heating circuit (A)

In models that are not equipped with the HTR system, pool production should be connected to the heating circuit via an open / close 3-way valve. This type of connection allows non-simultaneous production for the pool on the one hand and heating or cooling on the other hand.

Connection to the HTR system (B)

In addition to the option mentioned above, pool production can be connected to the DHW circuit. This allows two options: exclusive pool production with the primary condenser and simultaneous heating / cooling and pool production through the HTR system.

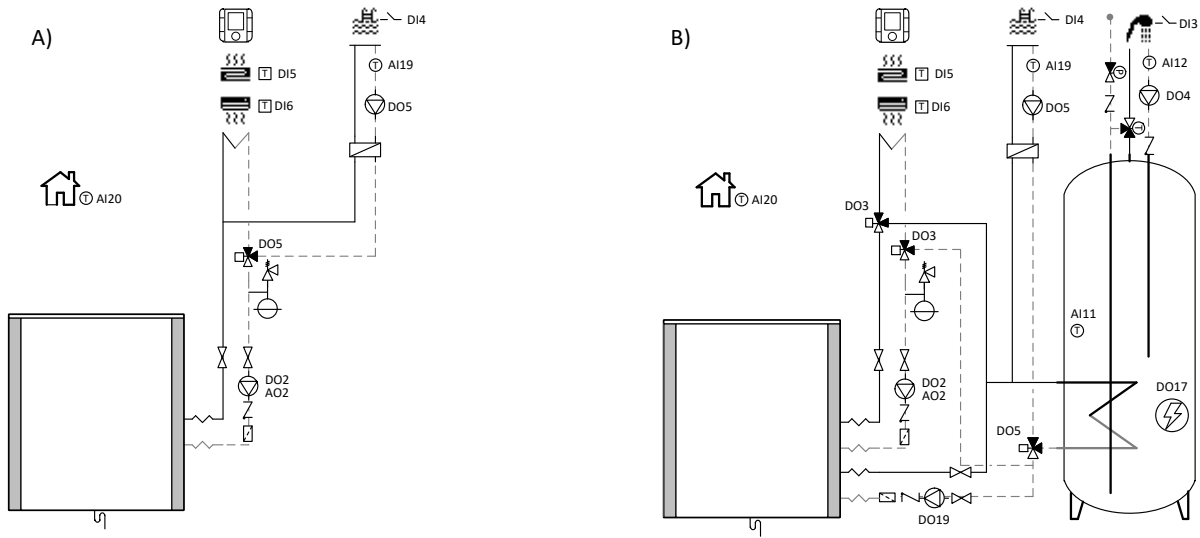

Figure 3.7. Pool production wiring schemes

4. Filling and discharge circuits



DANGER!

- During filling work on the hydraulic circuits, take special care to prevent liquid from spilling on the internal electrical heat pump components, which could cause personal injury due to electrocution and/or poor equipment operation.

4.1. Filling the production circuit (heating, cooling, DHW and pool)

Take the following steps to fill the circuit.

1. Open all the valves of the production circuits.
2. Fill the circuit through the filling valve until the target pressure is reached. Make sure that the pressure does not exceed 10 bar (pressure gauge) under any circumstance.
3. Remove the air from the circuit using the traps installed for that purpose.
4. Check the circuit pressure and repeat the filling process if necessary.

4.2. Filling the source circuit

The source system temperature can fall below 0°C, so a mixture of water/antifreeze must be used. It is recommended to use propylene glycol as an antifreeze additive or ethylene glycol with a corrosion inhibitor. Please check local regulations before using any type of antifreeze mixture.

When preparing the mixture, be careful to calculate the volume of antifreeze necessary to reach the desired degree of antifreeze protection. It is recommended to use a mixture with a freezing point at least 10°C below the nominal minimum temperature.

Source circuit filling should be done with the filling unit installed in the return pipe and an external circulation pump, taking the following steps.

1. Prepare the appropriate proportions of antifreeze mixture in external tank A.
2. Connect the external recirculation pump outlet to valve D.
3. Connect a transparent hose from valve E to antifreeze mixture tank A.
4. Close valve C and open filling valves D and E.
5. Start the external recirculation pump and keep it running until the return is completely free of air and the antifreeze mixture is mixed perfectly.
6. Open valve C and keep the external pump connected to remove the air between valves D and E.
7. Close valve E and pressurize the circuit to target pressure. Make sure that the pressure does not exceed 10 bar (pressure gauge) under any circumstance.
8. Close valve D.

After completing the source circuit filling process, it is recommended to check the concentration of antifreeze mixture again using a refractometer.

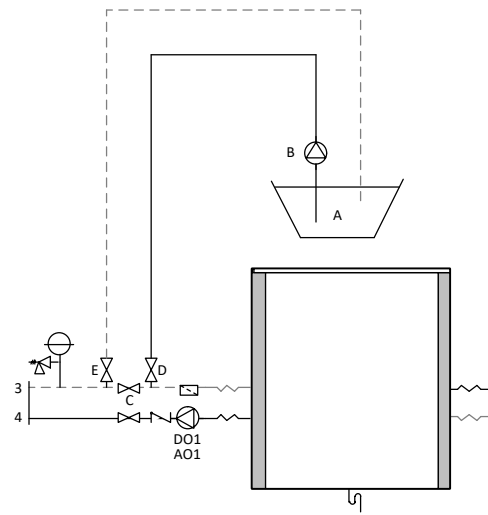

Figure 4.1. Filling the source circuit.

5. Electrical system



- **B**efore performing any operation on the electrical panel, disconnect the power supply.
- **R**emember that the heat pump has more than one electrical power supply.
- **E**coforest recommends that an external switch be installed for each of the electrical power sources (control, internal auxiliary equipment, and inverter).
- **A**ny intervention on the electrical system must only be performed by an authorised electrician in accordance with applicable local regulations and the instructions provided in this manual.
- **T**he cables used to connect the heat pump must comply with applicable national regulations.
- **I**nstall cables entering the heat pump in such a way that they have no voltage, cannot become corroded, are not affected by vibration, and do not touch sharp edges.
- **I**nstall power cables so that the ground cable is at least 50mm longer than the rest of the cables, to ensure that it is the last cable to be disconnected in case of accidental disconnection.
- **T**his unit is equipped with electrically powered safety measures. To be effective, the unit must be electrically powered at all times after installation, other than when servicing.
- **R**isk of electric shock. Can cause injury or death: System contains oversize protective earthing (grounding) terminal which shall be properly connected.

5.1. General instructions

The locations of the main electrical panel components are shown below.

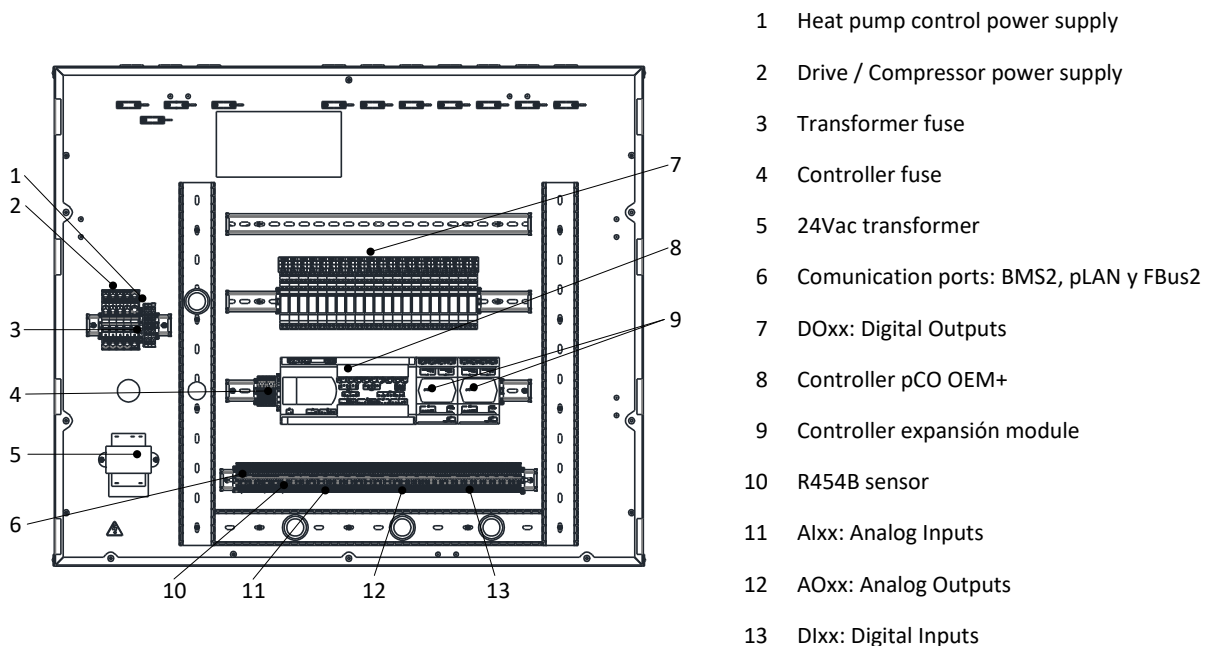

Figure 5.1. Location of the components in the electrical panel.

Several installation devices are controlled from the heat pump electrical panel. Some are internal and other are installed externally. The internal components are connected to the electrical panel in the factory. Depending on the installation that the heat pump is going to be connected to, in addition to the power supply, it may be necessary to connect various temperature probes (analogue inputs AIxx), control signals from thermostats or other external equipment (digital inputs DIxx) on/off switching of pumps and/or valves (digital outputs DOxx) or regulation of pumps and/or valves (analogue outputs AOxx).

The figure below shows a sample installation with the options for connecting external components to the heat pump.

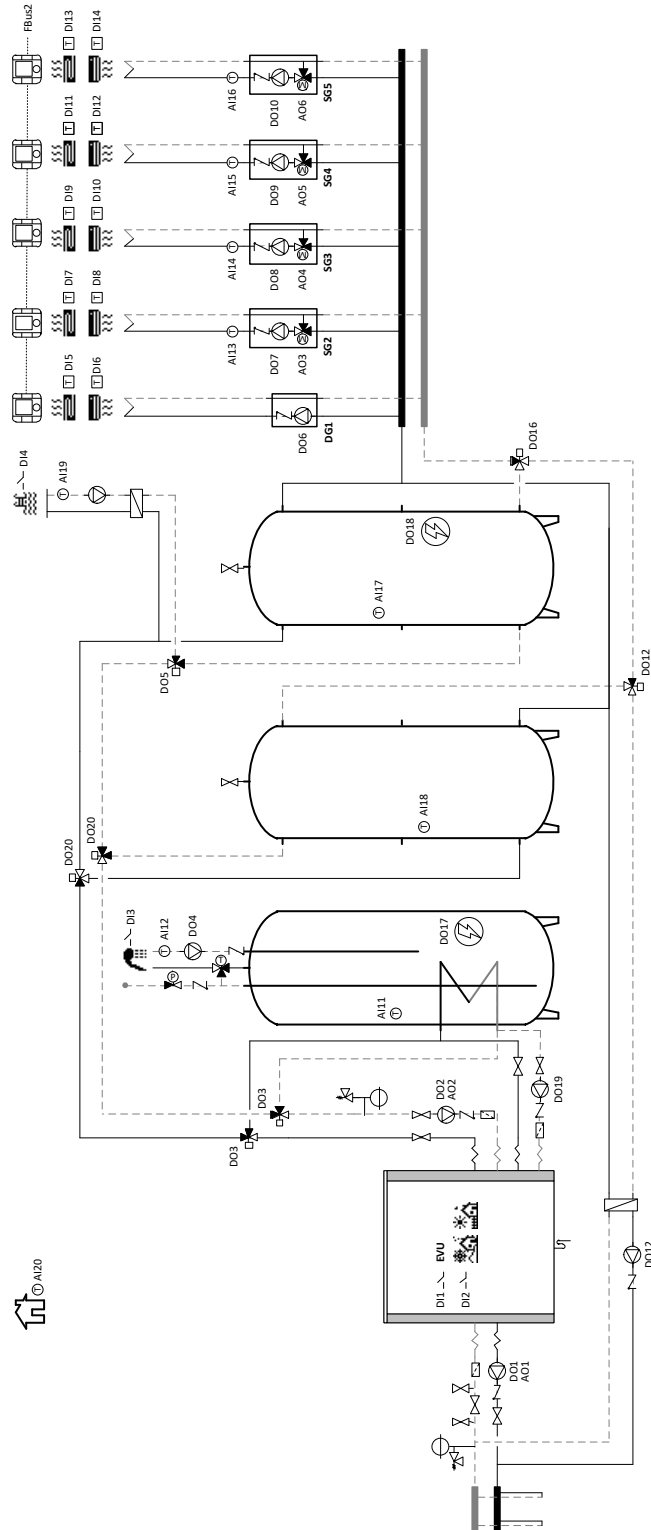

Figure 5.2. General electrical connections scheme of the heat pump.

Analogue inputs (A1xx)

These terminals are used to connect external temperature probes. Only passive NTC temperature probes can be connected, so cable connection polarity is not important.

If necessary, use extension cables with a maximum length of 50 m and a minimum diameter of 0,75 mm². For greater lengths (up to 120 m) it is recommended to use cable with a section of 1.5 mm².



NOTE

- Use original temperature probes only; other types of components could cause poor heat pump operation and/or cause heat pump component breakdowns.

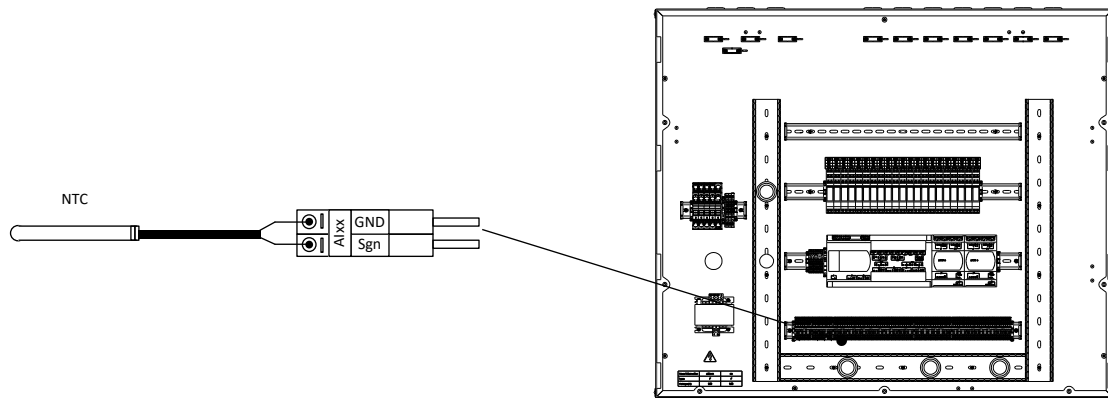

Figure 5.3. Example of temperature probe connections.

Digital control inputs (D1xx)

Digital signals from thermostats or other external devices can be connected to these terminals to control heat pump production functions.



NOTE

- Take special care with the working voltage of each digital input; improper handling could cause poor heat pump operation and/or heat pump component breakdowns. Some digital inputs require voltage-free signals, while others require 24Vac signals, 24Vac are powered by the terminal block connection.
- Do not combine free signal with 24Vac signal.

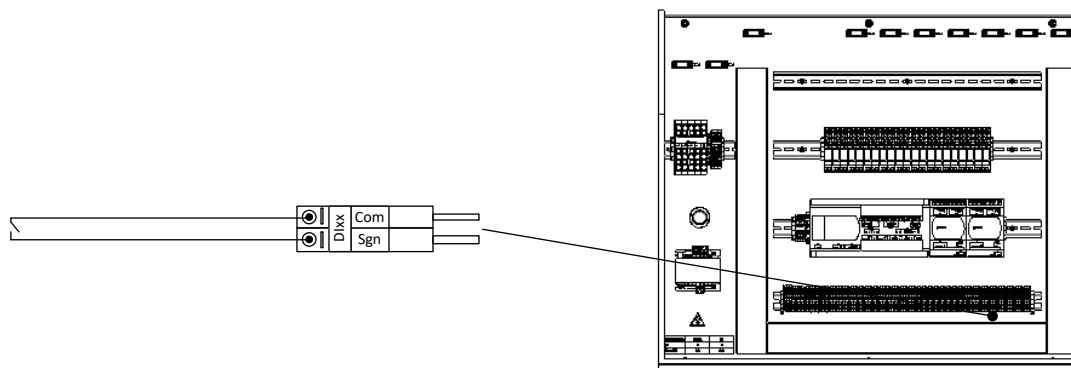

Figure 5.4. Example of voltage-free digital input connections.



NOTE

- Heat pump provides 24Vac connection from the electrical panel, all the devices connected to the heat pump cannot exceed 48VA or 2A. Exceed these limits could cause poor heat pump operation and/or heat pump component breakdowns.

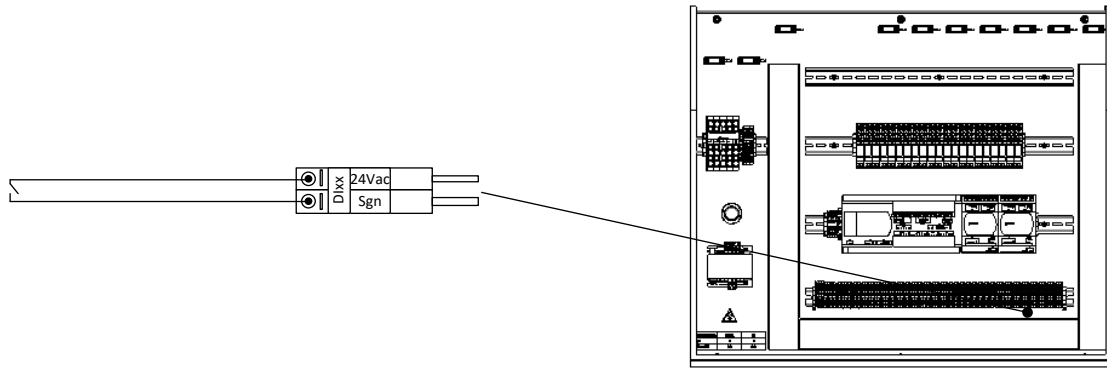

Figure 5.5. Example of digital input connections with 24Vac voltage.

Analogue outputs (AOxx)

These terminals send analogue 0-10Vdc regulation signals to modulate the control of outlet units with mixture, aerothermal source units with variable speed fan, external auxiliary boilers, etc. On the other hand, these connectors have a 24Vac power supply terminal to supply the modulating valve motor.

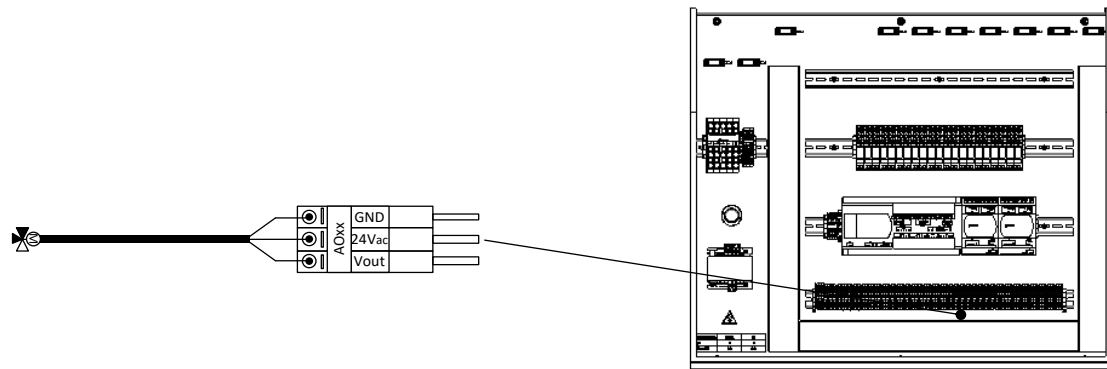

Figure 5.6. Example of 0-10Vdc modulating regulation signal connections.

Digital outputs to relay (DOxx)

The relay terminal block provides digital outputs to control external equipment, such as circulator pumps or open / closed valves. Each relay should be powered externally with the operating voltage of the component to be controlled. Power is supplied to each relay separately, so different operating voltages can be used in each. The following figure shows an example of an installation of a relay power supply.

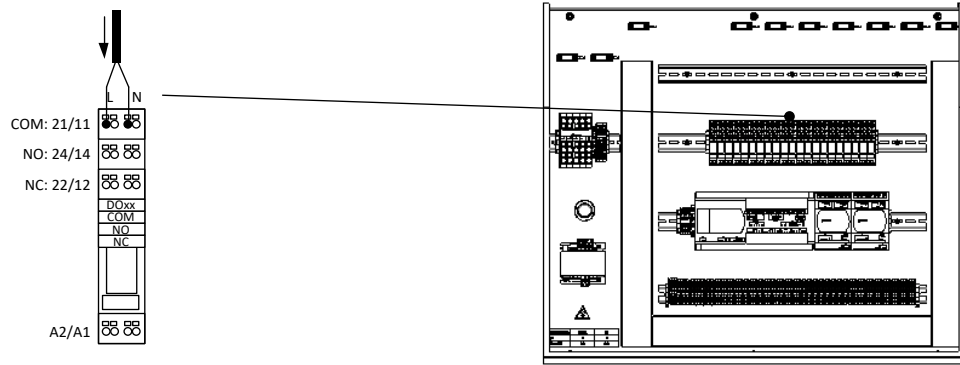

Figure 5.7. Example of digital output relay power supply connections.

Each relay allows independent pole switching; it can thus control the switching on/off of the units, including those powered with a different voltage. The capacity of the relays is 8A/250Vac per pole. If the equipment to be controlled exceeds this capacity, an external relay or contactor must be installed. Shown below are examples of connections between circulator pumps and 3-way valves with controls at 2 or 3 points.



NOTA

- Pay special attention to the maximum consumption allowed by each relay. Use an intermediate relay for the connection, if necessary.

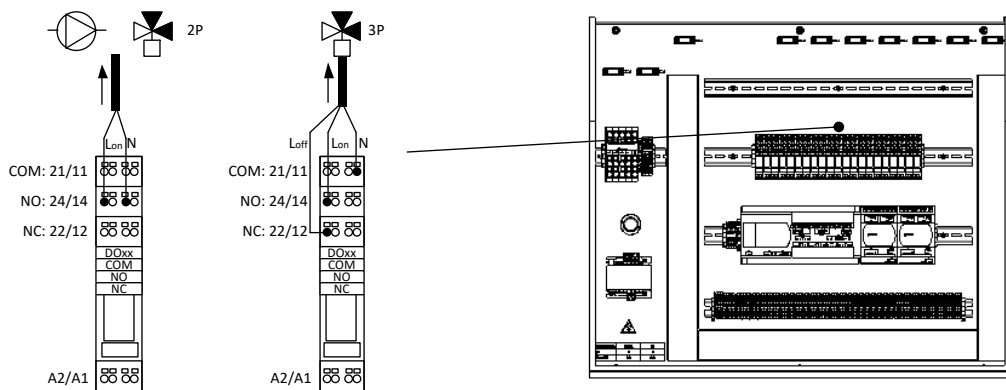

Figure 5.8. Example of digital output connections.

ModBus RS485 (FBus2) Communication Port

Internal terminals with thT bus communication data can be connected to this terminal.

5.2. Heat pump power supply



DANGER!

- The heat pump must be supplied with an external switch that can shut off all the circuits. Ecoforest recommend installing one external automatic breaker in each external power supply that provide full disconnection under overvoltage category III (control, internal auxiliary equipment and drive).

Ecoforest ecoGEO+ HP heat pumps require two power supply points. One for the power supply of the control panel; this unit includes the power supply of the internal and external valves and also that of the regulation signals and the digital and analogue inputs. The other power supply is exclusively dedicated to the compressor. Heat pumps must be powered via an automatic external differential switch which switches off all the circuits and which detects at least alternating or pulsating leakage currents with or without a continuous component, i.e. a type A or A HI component (LVA). In addition to the differential switch mentioned above, the heat pump must be protected by an external thermal-magnetic switch.

To carry out the electrical installation, insert the power cables through the cable grommet holes at the back of the heat pump. Continue by connecting the cables to the power terminal block of the heat pump, as described in figures 5.9 and 5.10.

Power supply of the control panel

The control panel power supply is always single-phase; the following table shows the characteristics of the necessary electrical connection:

Model	Type of power supply	Type of protection	Cut-off current	Recommended cable section
ecoGEO+ HP 400 170 R454B	1/N/PE 230 V / 50-60 Hz	Magnetic, thermal and differential protection	1 A	1 mm ² / AWG 16
ecoGEO+ HP 575 170 R454B				

Table 5.1. Characteristics of the control panel's power supply.

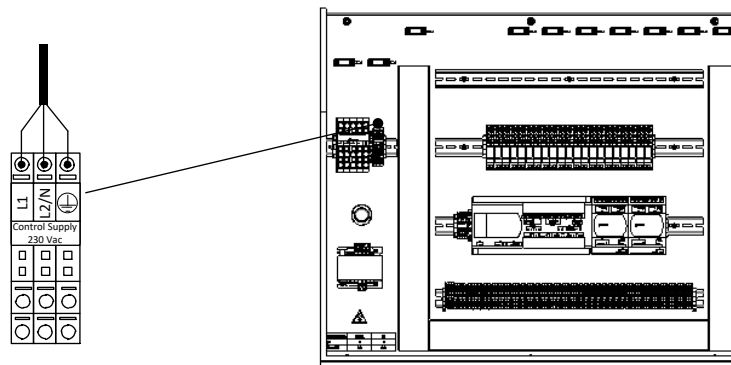

Figure 5.9. Connection scheme of the control panel's power supply.

Power supply of the compressor

The compressor power supply is always three-phase. The following table shows the characteristics of the necessary electrical connection.

Model	Type of power supply	Type of protection	Cut-off current	Recommended cable section
ecoGEO+ HP 400 170 R454B	3/PE 400V / 50-60Hz	Magnetic, thermal and differential protection	55 A	16 mm ² / AWG 6
ecoGEO+ HP 575 170 R454B	3/PE 575V / 60Hz		49 A	16 mm ² / AWG 6

Table 5.2. Characteristics of the electrical power supply of the compressor.

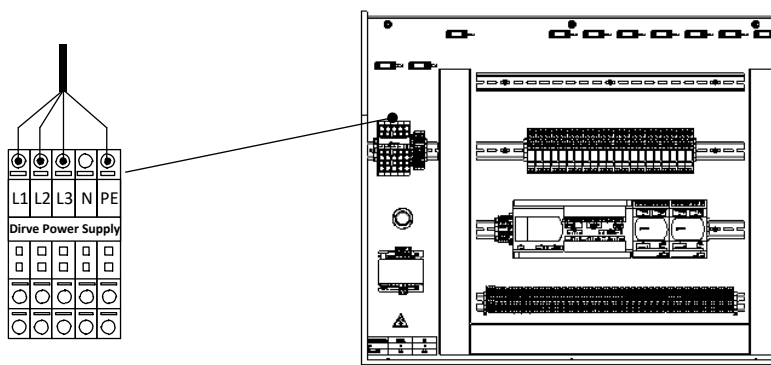

Figure 5.10. Connection scheme of the power supply of the compressor.

5.3. External protections

It is equipped with a connector that can be connected to various types of external mechanical protections, such as flow switches, pressure switches, thermostats, etc.

The ESS connector is used to connect these protections. The external protection devices are powered from the heat pump connector.

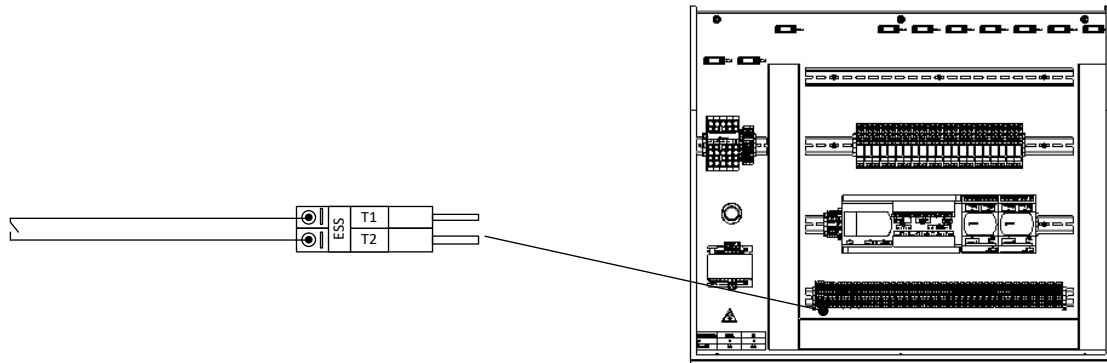

Figure 5.11. Connection scheme of the external protection devices.

5.4. Outside temperature probe

The outside temperature probe, supplied with the heat pump, has to be installed for the heat pump to work properly. Follow the instructions below to install it.

- Install the outside probe in a well-ventilated area, but protected from wind and rain.
- Do not install the outside probe at a distance of less than 1 m from windows or doors to avoid the effect of possible currents of warm air.
- Use a shielded 2-pole cable to prevent interferences.

Description	Signal	Type	Connector
Outside temperature probe	Analogue input	NTC 10K 25°C Probe	AI20

Table 5.3. Outside temperature probe connection terminal.

5.5. External storage systems

These can be used to control DHW storage, heating and cooling temperatures using temperature probes.

Description	Signal	Type	Connector
DHW inter-accumulator	Analogue input	NTC 10K 25°C Probe	AI11
Heating buffer storage tank	Analogue input	NTC 10K 25°C Probe	AI17
Cooling buffer storage tank	Analogue input	NTC 10K 25°C Probe	AI18

Table 5.4. Connection terminals for outlet units.

5.6. External production equipment

These are used to control production equipment handling of the various services, such as bypass valves or circulatory pumps.

Description	Signal	Type	Connector
Source pump	Digital output	Activation 230Vac / 8A maximum	DO1
	Analogue output	Valve regulation 0 – 10Vdc	AO1
Production pump	Digital output	Activation 230Vac / 8A maximum	DO2
	Analogue output	Valve regulation 0 – 10Vdc	AO2
DHW production	Digital output	Activation 230Vac / 8A maximum	DO3
DHW Recirculation	Analogue input	NTC 10K 25°C Probe	AI12
	Digital output	Activation 230Vac / 8A maximum	DO4
Pool production	Analogue input	NTC 10K 25°C Probe	AI19
	Digital output	Activation 230Vac / 8A maximum	DO5
Active cooling production	Digital output	Activation 230Vac / 8A maximum	DO11
Passive cooling production	Digital output	Activation 230Vac / 8A maximum	DO12
Auxiliary source pump	Digital output	Activation 230Vac / 8A maximum	DO14
Auxiliary cooling pump	Digital output	Activation 230Vac / 8A maximum	DO15
Heating / cooling consumption	Digital output	Activation 230Vac / 8A maximum	DO16
HTR production	Digital output	Activation 230Vac / 8A maximum	DO19
Heating / cooling production	Digital output	Activation 230Vac / 8A maximum	DO20

Table 5.5. Auxiliary equipment connection terminals.

5.7. Simultaneous production

In installations with simultaneous production, the 0-10Vdc regulation signals of the cooling and heating circuit circulator pumps are used to control the modulating 3-way valves that bypass to the support collector. As a result, only the digital activation signal is used for the circulator pumps.

Description	Signal	Type	Connector
Cooling pump	Digital output	Activation 230Vac / 2A maximum	DO1
Heating pump	Digital output	Activation 230Vac / 2A maximum	DO2
Cooling valve	Analogue output	Regulation 0 – 10Vdc	AO1
Heating valve	Analogue output	Regulation 0 – 10Vdc	AO2

Table 5.6. Connection terminals for installations with simultaneous production.

5.8. DG1 – SG5 Outlet Units

The heat pump can control a direct outlet unit (DG1) and four outlet units with mixture (SG2, SG3, SG4 and SG5). Unit activation can be controlled according to heating or cooling demand. In addition, the units with mixture can measure the unit's outlet temperature and generate a regulation signal for the 3-way modulating valve.

Description	Signal	Type	Connector
DG1 direct unit	Digital output	Activation 230Vac / 2A maximum	DO6
SG2 unit with mixture	Analogue input	NTC 10K 25°C Probe	AI13
	Analogue output	Valve regulation 0 – 10Vdc	AO3
	Digital output	Activation 230Vac / 2A maximum	DO7
SG3 unit with mixture	Analogue input	NTC 10K 25°C Probe	AI14
	Analogue output	Valve regulation 0 – 10Vdc	AO4
	Digital output	Activation 230Vac / 2A maximum	DO8
SG4 unit with mixture	Analogue input	NTC 10K 25°C Probe	AI15
	Analogue output	Valve regulation 0 – 10Vdc	AO5
	Digital output	Activation 230Vac / 2A maximum	DO9
SG5 unit with mixture	Analogue input	NTC 10K 25°C Probe	AI16
	Analogue output	Valve regulation 0 – 10Vdc	AO6
	Digital output	Activation 230Vac / 2A maximum	DO10

Table 5.7. Connection terminals for outlet units.



NOTE

- Heat pump provides 24Vac connection from the electrical panel, remember that all the devices connected to the heat pump cannot exceed 48VA or 2A. Exceed these limits could cause poor heat pump operation and/or heat pump component breakdowns.

5.9. External auxiliary equipment

This is used to control the activation of the auxiliary equipment integrated in the DHW heating buffer storage tanks via outputs to relays. They are also used to control activation of all / nothing external auxiliary boiler. If modulating boilers are installed, it is also used to control the temperature downstream from the boiler, so the heat pump and the boiler can function simultaneously.

The connection terminals of the SG5 outlet unit are used to manage the auxiliary boilers, so this one cannot be used.

Description	Signal	Type	Connector
Auxiliary heating buffer storage tank equipment	Digital output	Activation 230Vac / 8A maximum	DO18
DHW inter-storage tank auxiliary equipment	Digital output	Activation 230Vac / 8A maximum	DO17
Auxiliary cooling	Analogue input	NTC 10K 25°C Probe	AI15
	Analogue output	Valve regulation 0 – 10Vdc	AO5
	Digital output	Activation 230Vac / 8A maximum	DO9
Auxiliary boiler	Analogue input	NTC 10K 25°C Probe	AI16
	Analogue output	Valve regulation 0 – 10Vdc	AO6
	Digital output	Activation 230Vac / 8A maximum	DO10

Table 5.8. Auxiliary equipment connection terminals.

5.10. Alarm signal

If the heat pump cannot start up the compressor because of an active alarm, the heat pump will generate an alarm signal.

Description	Signal	Type	Connector
Alarm signal	Relay digital output	Activation 230Vac / 8A maximum	DO13

Table 5.9. Alarm signal connection terminal.

5.11. Remote services production control

The heat pump is equipped with digital inputs for remote control of production services.

Description	Signal	Type	Connector
Control of electrical consumption (EVU)	Digital input	Voltage-free (0V)	DI1
WINTER / SUMMER program selection	Digital input	Voltage-free (0V)	DI2
Enable / disable DHW production	Digital input	Voltage-free (0V)	DI3
Pool production	Digital input	Voltage-free (0V)	DI4
1 SG signal	Digital input	24Vdc / 24Vac signal	DI15
2 SG signal	Digital input	24Vdc / 24Vac signal	DI16

Table 5.10. Connection terminals for digital inputs that control service production.

Heat pump start-up control (EVU signal)

Enables / disables energy production with both the compressor and the auxiliary equipment. In any event, circulator pumps, valves and other components can be activated to consume energy from the storage systems.

Remote WINTER / SUMMER program selection

Used for remote selection of the heat pump operation program.

DHW production

Enables / disables the DHW production function. If the function is enabled, DHW production is governed by the DHW configuration in the heat pump controller.

Pool production

Activates / deactivates pool production demand. If the signal is requested, pool production is governed by the pool configuration in the heat pump controller.

SMART GRID

Enables / disables the SG states of the heat pump. Depending on the value of the digital inputs, there are four SG operating statuses:

SG1 [0 0] (Normal state): The heat pump is operating normally, as per its configuration.

SG2 [0 1] (Reduced tariff): As we are in a reduced tariff period, we will take advantage of the lower price of electricity to use the pump to produce heat or cold.

SG3 [1 0] (Block status): Signal for compressor blocking to the heat pump.

SG4 [1 1] (Forced state): The heat pump will force the maximum possible consumption in the installation to help balance the network.

These external signals can be sent by the electricity company itself to endeavor to keep the distribution network balanced at all times.

5.12. Inside environment control

The heating and cooling functions can be controlled by digital signals from relay thermostats, by interior terminals with thT bus communication, by a combination of both or not using any interior control terminal.

Relay thermostats

Each outlet unit, from DG1 to SG5, has two 24Vac or 24Vdc digital signals to activate heating or cooling requests from the interior thermostats or other external control devices.

Description	Signal	Type	Connector
DG1 direct unit heating request	Digital input	24Vdc / 24Vac signal	DI5
DG1 direct unit cooling request	Digital input	24Vdc / 24Vac signal	DI6
SG2 mix unit heating request	Digital input	24Vdc / 24Vac signal	DI7
SG2 mix unit cooling request	Digital input	24Vdc / 24Vac signal	DI8
SG3 mix unit heating request	Digital input	24Vdc / 24Vac signal	DI9
SG3 mix unit cooling request	Digital input	24Vdc / 24Vac signal	DI10
SG4 mix unit heating request	Digital input	24Vdc / 24Vac signal	DI11
SG4 mix unit cooling request	Digital input	24Vdc / 24Vac signal	DI12
SG5 mix unit heating request	Digital input	24Vdc / 24Vac signal	DI13
SG5 mix unit cooling request	Digital input	24Vdc / 24Vac signal	DI14

Table 5.11. Connection terminals for digital inputs that control outlet units DG1 - SG4.

A single thermostat or several thermostats connected in parallel can be used for each outlet unit, as shown below.

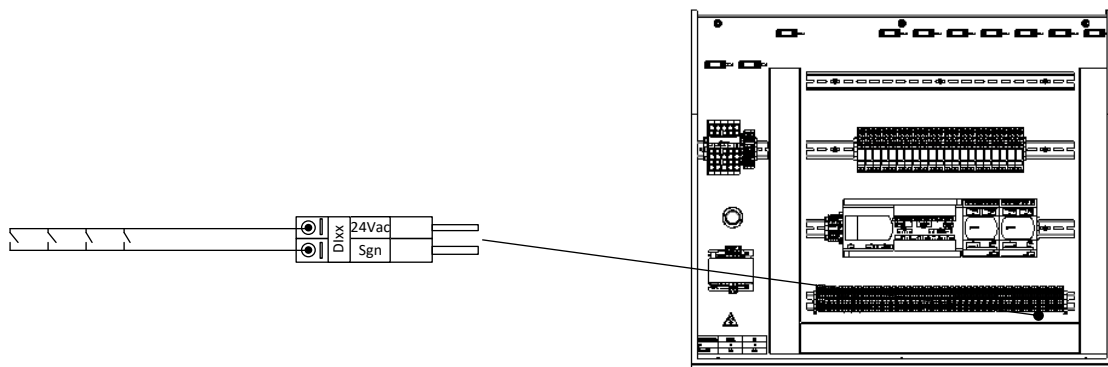

Figure 5.12. Example of connection of several thermostats in parallel.

thT bus terminals

In addition to digital input control (interior thermostats) interior terminals with thT data bus communication can also be used. These terminals capture the inside temperature and humidity of the area associated with each outlet unit, DG1 – SG5, using a serial cable over a Modbus protocol. They also have a digital output to control a valve for the area. A single thT terminal can be connected per outlet unit.

Read the assembly instructions carefully before installing the terminals.

Description	Signal	Connector
thT terminal communication bus	ModBus RS485	FBus2

Table 5.12. Data bus connection terminals for the thT terminals.

Follow the recommendations below to connect the thT terminals to the heat pump.

- Use a three-pole, shielded AWG 20-22 cable for the connection.
- Connect the terminals in series for installations with more than one terminal in the network. The maximum length of the circuit assembly should not exceed 500 meters. For connection networks with more than two thTs, it is necessary to install a 120 Ohm heater between Rx+/Tx+ and Rx-/Tx- in the first and last terminal to prevent possible communication problems.
- Configure the terminal address according to the settings of the controller following the steps described in the thT terminal manual.

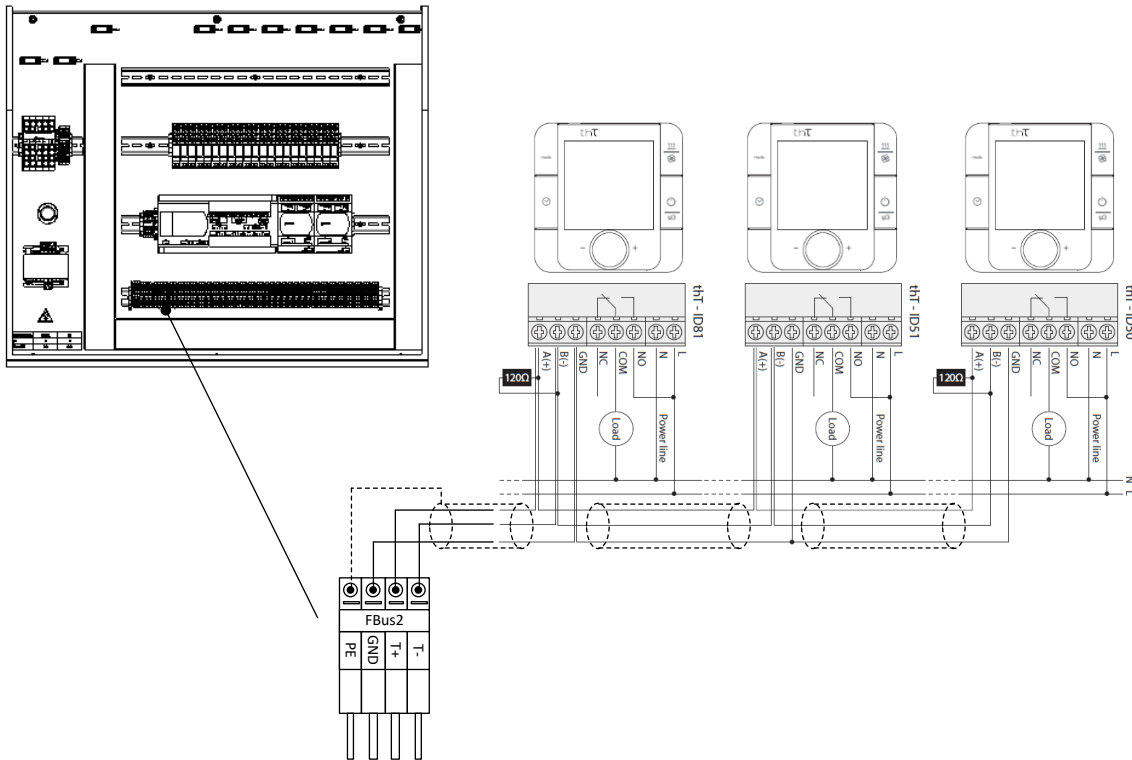

Figure 5.13. Example of connection of thT terminals.

Installation without interior terminals

The ecoGEO+ heat pumps can also be used in installations that do not have any type of interior terminal to generate request signals. In these cases, a continuous request can be imposed at the digital input of the unit to activate by selecting the appropriate control logic in the controller. As a result, the heat pump will run the start / stop cycles according to the temperature control of the circuit and the outside cut-off temperatures of each service.

5.13. Remote control by BUS

The heat pump allows MODBUS communication. Signals can be sent to switch the heat pump on and off, activate the demand for DHW, pool or heating or cooling services for each configured outlet unit and vary the setpoints for DHW, pool and for both heating and cooling in each unit.

Description	Signal	Connector
MODBUS read and write	ModBus RS485	BMS2

Table 5.13. Read and write data bus connection terminals.

Follow the recommendations below for connecting the converters.

- Use a three-pole, shielded AWG 20-22 cable for the connection.
- For installations with more than one heat pump, connect the terminals in series. The maximum length of the circuit assembly should not exceed 500 meters.
- Configure the BMS2 terminal address on the controller following the steps laid out in the technical service manual.

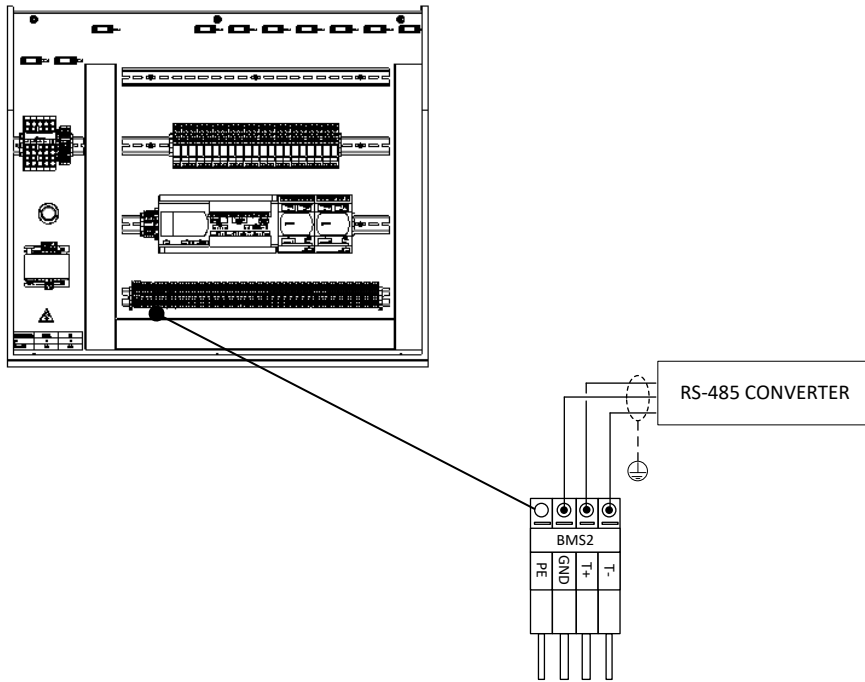

Figure 5.14. Example shown: an RS-485 converter connection for read write data on the heat pump.



NOTE

- For more information about BUS connections, please contact your distributor.

5.14. Energy meter

The heat pump allows MODBUS communication with energy meters supplied by Ecoforest. Before installing the energy meter, carefully read its assembly instructions.

Description	Signal	Connector
Energy meter BUS communication	ModBus RS485	FBus2

Table 5.14. Data bus connection terminals for the energy meter.

Follow the recommendations below to connect the energy meter to the heat pump.

- Use a three-pole, shielded AWG 20-22 cable for the connection.
- Connect the terminals in series for installations with more than one terminal in the network. The maximum length of the circuit assembly should not exceed 500 meters. For connection networks with more than two thTs, it is necessary to install a 120 Ohm heater between Rx+/Tx+ and Rx-/Tx- in the first and last terminal to prevent possible communication problems.
- To install the device supplied by Ecoforest, follow the steps in the manufacturer's installation manual included with the equipment. It is necessary to configure a 100 address on the measurement device for proper communication with your heat pump (See control applications manual).

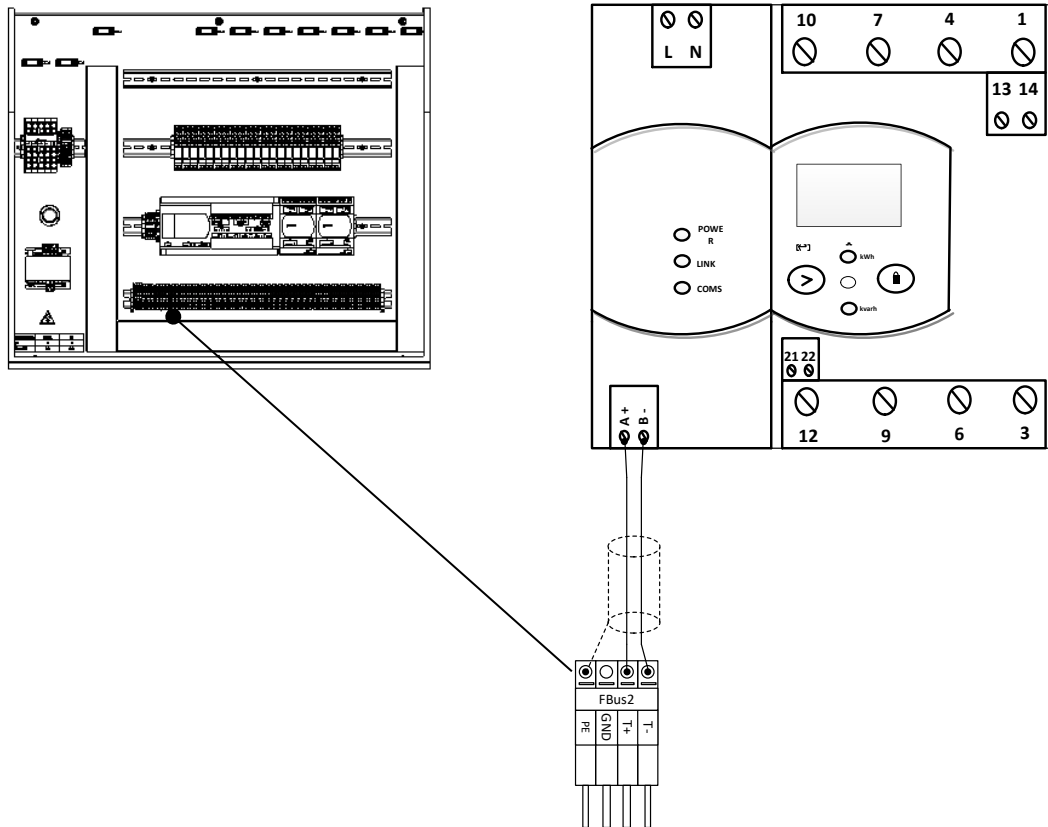

Figure 5.15. Example of connection of energy meter.

5.15. R454B leak detector



DANGER!

- Leak detection system installed. Unit must be powered except for service.

The heat pump allows MODBUS communication with R454B leak detectors supplied by Ecoforest. Before installing this sensor, carefully read its assembly instructions.

Description	Signal	Connector
R454B sensor BUS communication	ModBus RS485	FBus2

Table 5.15. Data bus connection terminals for the energy meter.

Follow the recommendations below to connect the energy meter to the heat pump.

6. Start-up

Check the following items before starting up the heat pump. Not doing so could result in poor heat pump operation and/or serious heat pump damage.

1. All the hydraulic circuits of the installation have been properly filled and bled.
2. The cut-off valves of the hydraulic source and production circuits are open.
3. An external switch has been installed to cut off all the power supply circuits of the heat pump.
4. The heat pump power supply has the proper voltage and allows sufficient consumption to start up the compressor.
5. The inside room temperature of the home is at least 18°C. Otherwise, the temperature has to be increased by auxiliary equipment.

7. Technical specifications

7.1. Component location

No.	Description	No.	Description
1	Production outlet	17	Source inlet temp. probe
2	Production return	18	Production outlet temp. probe
3	Source outlet	19	Production inlet temp. probe
4	Source return	20	Suction pressure transducer
5	HTR outlet	21	Discharge pressure transducer
6	HTR return	22	Source pressure transducer
7	Evaporator (direct cycle)	23	Production pressure transducer
8	Condenser (direct cycle)	24	Suction mini-pressure switch
9	HTR heat exchanger	25	Discharge mini-pressure switch
10	Compressor	26	Electrical panel
11	Electronic expansion valve	27	Service outlet
12	Filter dryer	28	Liquid level glass
13	Cycle inversion valve	29	Compressor oil display
14	Compressor suction temp. probe	30	Oil solenoid valve
15	Compressor discharge temp. probe	31	R454B sensor
16	Source outlet temp. probe		

ecoGEO+ HP1 400 170 R454B / ecoGEO+ HP1 575 170 R454B

EN

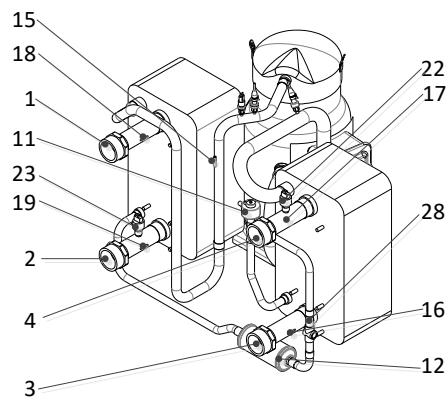
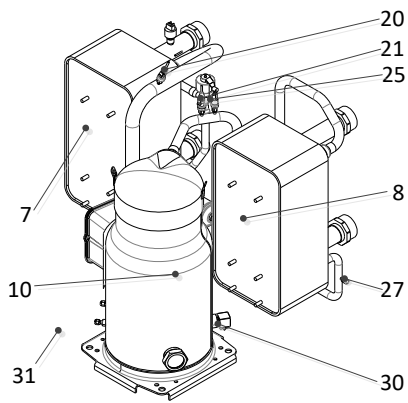
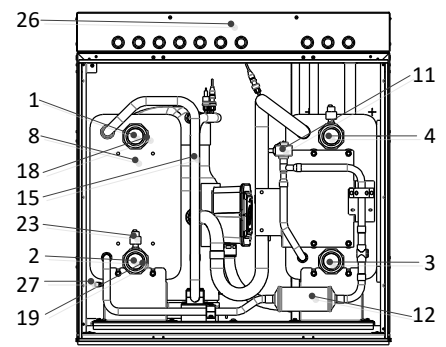
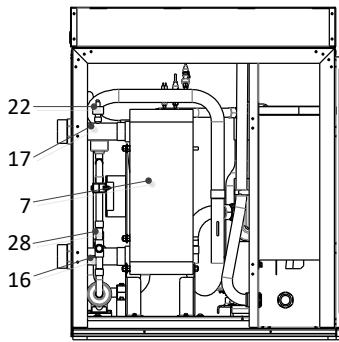
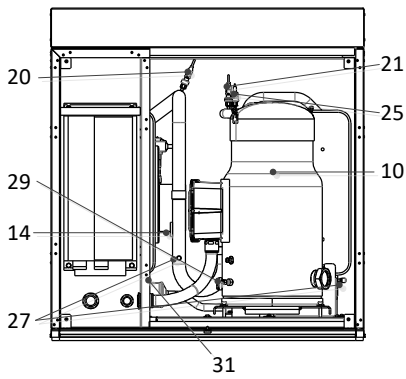
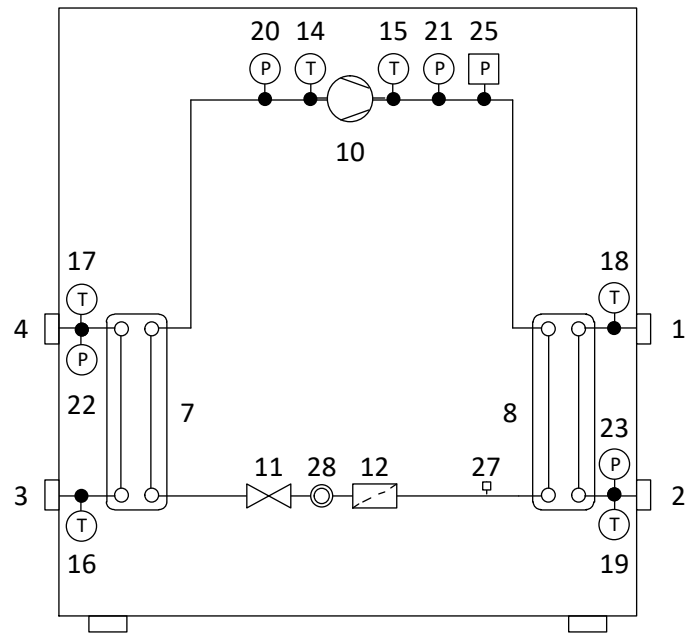

ecoGEO+ HP1 400 170 R454B HTR / ecoGEO+ HP1 575 170 R454B HTR

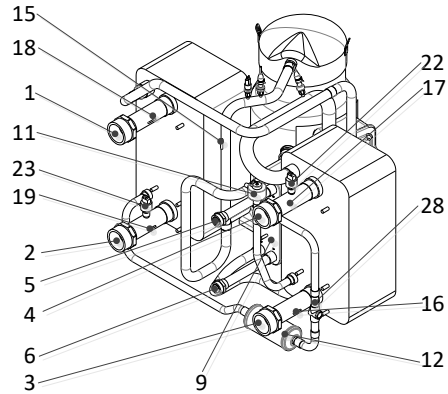
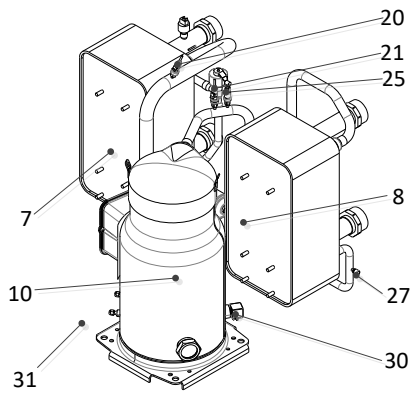
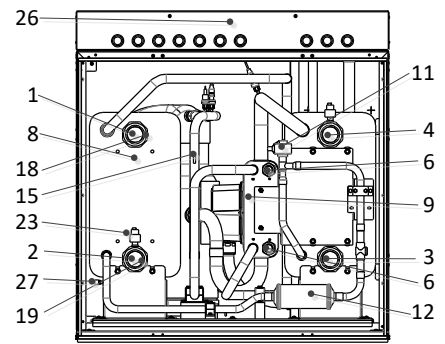
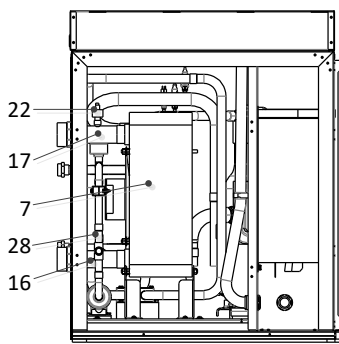
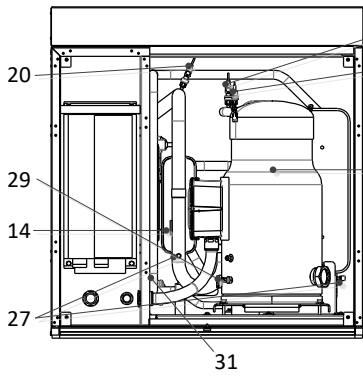
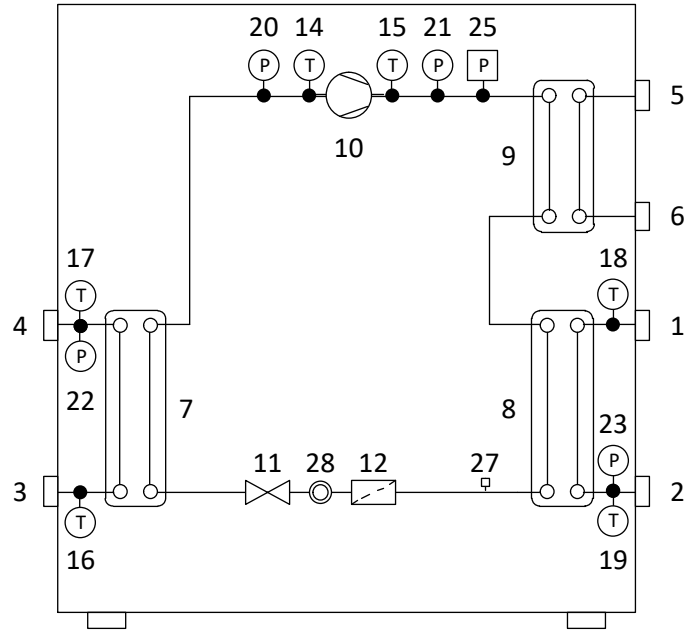

ecoGEO+ HP3 400 170 R454B / ecoGEO+ HP3 575 170 R454B

EN

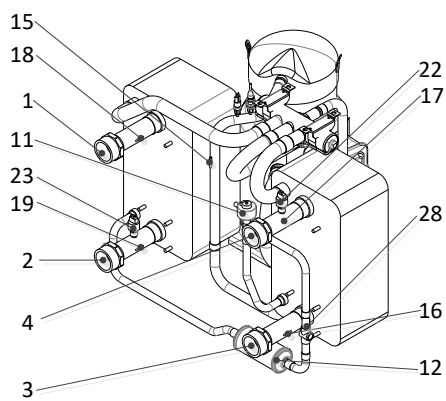
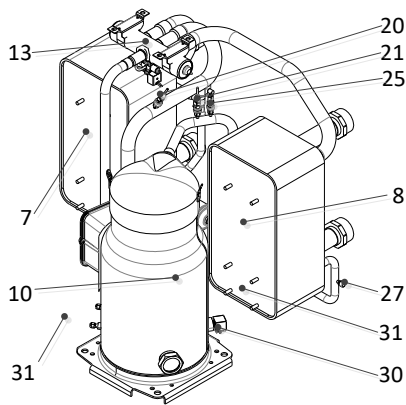
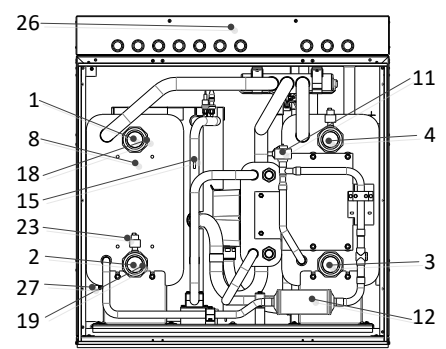
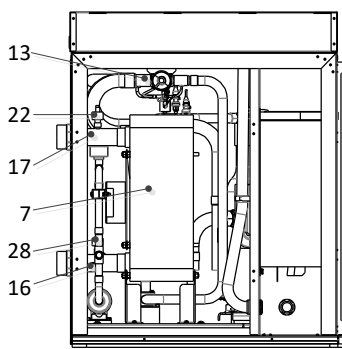
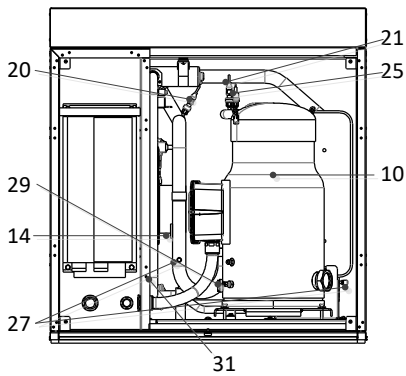
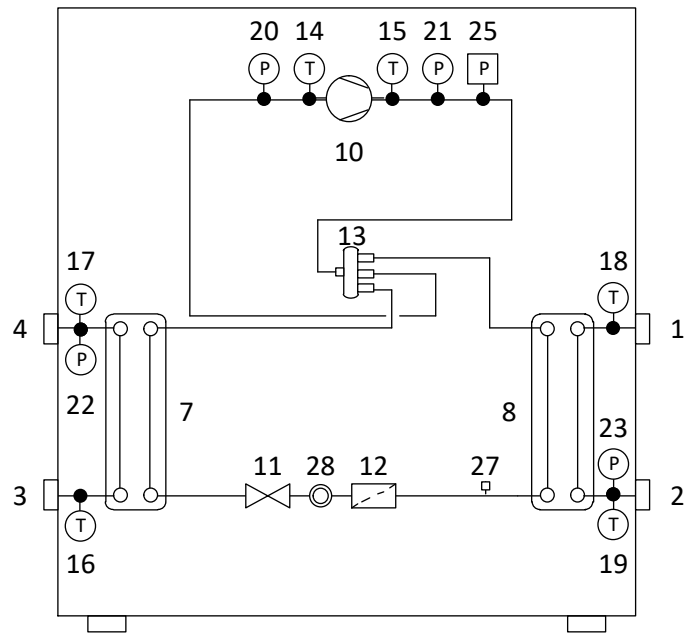

ecoGEO+ HP3 400 170 R454B HTR / ecoGEO+ HP3 575 170 R454B HTR

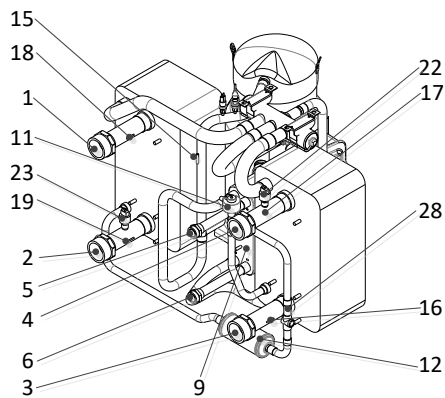
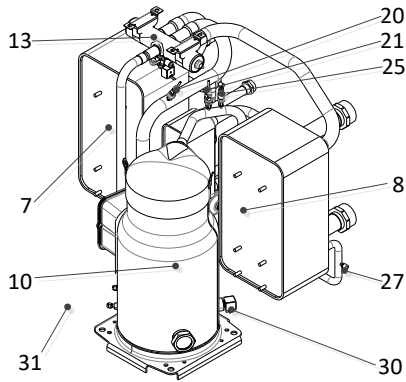
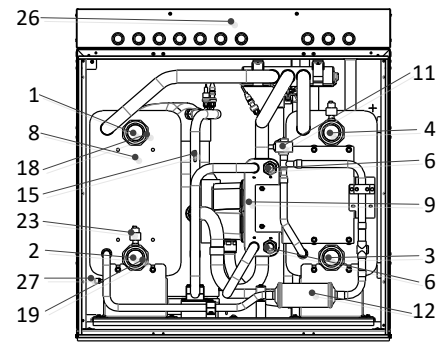
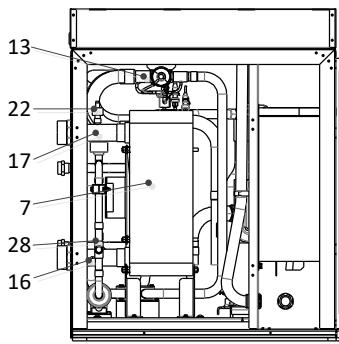
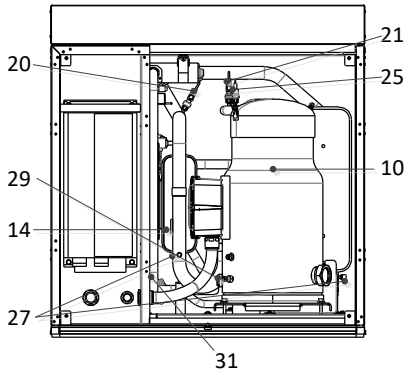
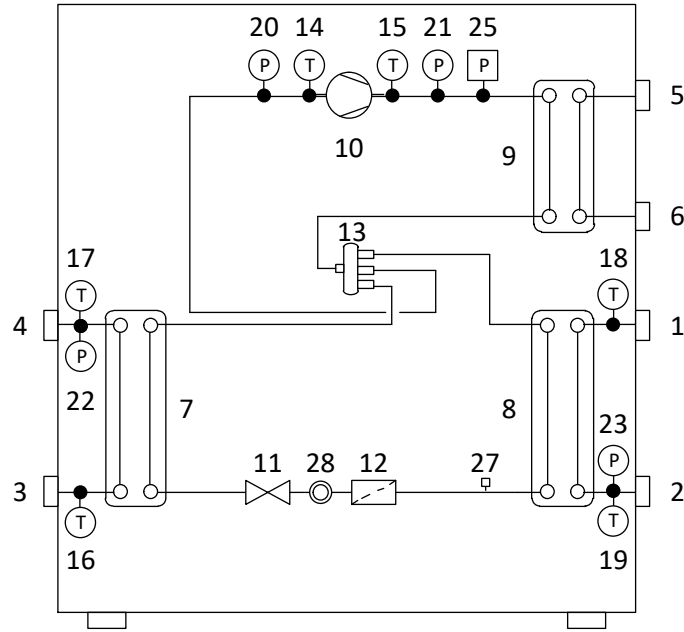

7.2. Power circuit diagram

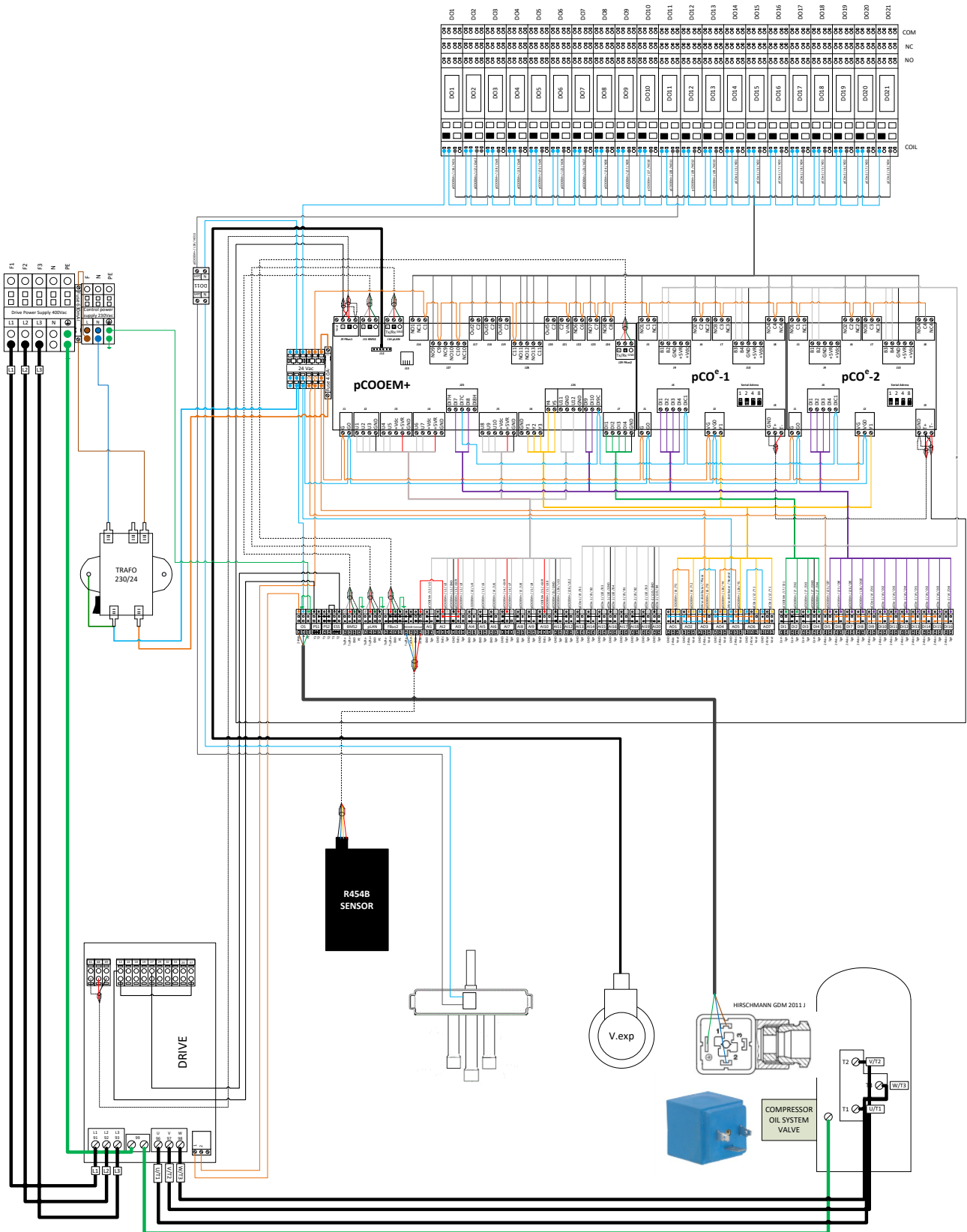

EN

7.3. Electrical connection tables

DIGITAL OUTPUTS			
CONNECTIONS		DESCRIPTION	
Connection terminal	Controller terminal	Type	Signal
Block I / DO1	pCOOEM+ / J16 / NO1	Activation 230Vac / 8A max	Source circulation pump
Block I / DO2	pCOOEM+ / J17 / Out2	Activation 230Vac / 8A max	Production circulation pump
Block I / DO3	pCOOEM+ / J18 / Out3	Activation 230Vac / 8A max	DHW production
Block I / DO4	pCOOEM+ / J19 / Out4	Activation 230Vac / 8A max	DHW Recirculation
Block I / DO5	pCOOEM+ / J20 / Out5	Activation 230Vac / 8A max	Pool production
Block I / DO6	pCOOEM+ / J22 / NO6	Activation 230Vac / 8A max	DG1 group production
Block I / DO7	pCOOEM+ / J23 / NO7	Activation 230Vac / 8A max	SG2 group production
Block I / DO8	pCOOEM+ / J24 / NO8	Activation 230Vac / 8A max	SG3 group production
Block I / DO9	pCOOEM+ / J27 / NO9	Activation 230Vac / 8A max	SG4 group production / Auxiliary cooling
Block I / DO10	pCOOEM+ / J27 / NO10	Activation 230Vac / 8A max	SG5 group production / Auxiliary boiler
Block I / DO11	pCOOEM+ / J28 / NO11	Activation 230Vac / 8A max	Active cooling production
Block I / DO12	pCOOEM+ / J28 / NO12	Activation 230Vac / 8A max	Passive cooling production
Block I / DO13	pCOOEM+ / J28 / NO13	Activation 230Vac / 8A max	Alarm signal
Block I / DO14	pCOe-1 / J5 / NO1	Activation 230Vac / 8A max	Auxiliary source circulation pump
Block I / DO15	pCOe-1 / J6 / NO2	Activation 230Vac / 8A max	Cooling auxiliary circulator pump
Block I / DO16	pCOe-1 / J7 / NO3	Activation 230Vac / 8A max	Heating / cooling consumption
Block I / DO17	pCOe-1 / J8 / NO4	Activation 230Vac / 8A max	DHW inter-accumulator resistor
Block I / DO18	pCOe-2 / J5 / NO1	Activation 230Vac / 8A max	Buffer storage tank resistor
Block I / DO19	pCOe-2 / J6 / NO2	Activation 230Vac / 8A max	HTR
Block I / DO20	pCOe-2 / J7 / NO3	Activation 230Vac / 8A max	Heating / cooling production
Block I / DO21	pCOe-2 / J8 / NO4	Activation 230Vac / 8A max	Not used

PROTECTIONS		
CONNECTIONS	DESCRIPTION	
Connection terminal	Type	Signal
Block II / PS1	Safety switch	Low pressure switch
Block II / PS2	Safety switch	High pressure switch
Block II / ESS	Safety switch	External safety switch

COMMUNICATIONS			
CONNECTIONS		CONNECTIONS	
Connection terminal	Serial port	Serial port	Serial port
Block II / BMS2	pCOOEM+ / J11 BMS2	RS485 ModBus RTU	Remote access through bus
--	pCOOEM+ / BMS card	Card communication connector	
Block II / pLAN	pCOOEM+ / J14 pLAN	RS485 ModBus RTU	Controller network connector
Block II / FBus2	pCOOEM+ / J29 FBus2	RS485 ModBus RTU	Indoor terminals thT y th-Tune
			R454B sensor

ANALOGUE INPUTS			
CONNECTIONS		DESCRIPTION	
Connection terminal	Controller terminal	Type	Signal
Block II / AI1	pCOOEM+ / J2 / U1	NTC 10K 25°C	Compressor suction temperature
Block II / AI2	pCOOEM+ / J2 / U2	Radiometer 0-5Vdc	Compressor suction pressure
Block II / AI3	pCOOEM+ / J2 / U3	Radiometer 0-5Vdc	Compressor discharge pressure
Block II / AI4	pCOOEM+ / J3 / U4	NTC 50K 25°C	Compressor discharge temperature
Block II / AI5	pCOOEM+ / J3 / U5	NTC 10K 25°C	Source outlet temperature
Block II / AI6	pCOOEM+ / J4 / U6	NTC 10K 25°C	Source inlet temperature
Block II / AI7	pCOOEM+ / J4 / U7	Radiometer 0-5Vdc	Source circuit pressure
Block II / AI8	pCOOEM+ / J5 / U8	NTC 10K 25°C	Production outlet temperature
Block II / AI9	pCOOEM+ / J5 / U9	NTC 10K 25°C	Production inlet temperature
Block II / AI10	pCOOEM+ / J5 / U10	Radiometer 0-5Vdc	Production circuit pressure
Block II / AI11	pCOOEM+ / J26 / U11	NTC 10K 25°C	DHW inter-accumulator temperature
Block II / AI12	pCOOEM+ / J26 / U12	NTC 10K 25°C	DHW recirculation temperature
Block II / AI13	pCOe-1 / J9 / B1	NTC 10K 25°C	Mixture group 2 temperature
Block II / AI14	pCOe-1 / J9 / B2	NTC 10K 25°C	Mixture group 3 temperature
Block II / AI15	pCOe-1 / J10 / B3	NTC 10K 25°C	Mixture group 4 temperature / Auxiliary cooling
Block II / AI16	pCOe-1 / J10 / B4	NTC 10K 25°C	Mixture group 5 temperature / Auxiliary boiler
Block II / AI17	pCOe-2 / J9 / B1	NTC 10K 25°C	Heating buffer temperature
Block II / AI18	pCOe-2 / J9 / B2	NTC 10K 25°C	Cooling buffer temperature
Block II / AI19	pCOe-2 / J10 / B3	NTC 10K 25°C	Pool temperature
Block II / AI20	pCOe-2 / J10 / B4	NTC 10K 25°C	Outside temperature

ANALOGUE OUTPUTS			
CONNECTIONS		DESCRIPTION	
Connection terminal	Controller terminal	Type	Signal
Block II / AO1	pCOOEM+ / J6 / Y1	0-10Vdc	Source pump adjustment
Block II / AO2	pCOOEM+ / J6 / Y2	0-10Vdc	Production pump adjustment
Block II / AO3	pCOOEM+ / J6 / Y3	0-10Vdc	Regulation of mixture group 2
Block II / AO4	pCOOEM+ / J26 / Y4	0-10Vdc	Regulation of mixture group 3
Block II / AO5	pCOOEM+ / J26 / Y5	0-10Vdc	Regulation of mixture group 4 / Regulation of auxiliary cooling
Block II / AO6	pCOe-1 / J2 / Y1	0-10Vdc	Regulation of mixture group 5 / Regulation of auxiliary boiler
Block II / AO7	pCOe-2 / J2 / Y1	0-10Vdc	Not used

DIGITAL INPUTS			
CONNECTIONS		DESCRIPTION	
Connection terminal	Controller terminal	Type	Signal
Block II / DI1	pCOOEM+ / J7 / DI1	Voltage free (0V)	Electrical consumption control (EVU)
Block II / DI2	pCOOEM+ / J7 / DI2	Voltage free (0V)	WINTER / SUMMER selection
Block II / DI3	pCOOEM+ / J7 / DI3	Voltage free (0V)	DHW production
Block II / DI4	pCOOEM+ / J7 / DI4	Voltage free (0V)	Pool production
Block II / DI5	pCOOEM+ / J25 / DI7	24Vdc / 24Vac	DG1 heating request
Block II / DI6	pCOOEM+ / J25 / DI8	24Vdc / 24Vac	DG1 cooling request
Block II / DI7	pCOOEM+ / J26 / DI9	24Vdc / 24Vac	SG2 heating request
Block II / DI8	pCOOEM+ / J26 / DI10	24Vdc / 24Vac	SG2 cooling request
Block II / DI9	pCOe-1 / J4 / DI1	24Vdc / 24Vac	SG3 heating request
Block II / DI10	pCOe-1 / J4 / DI2	24Vdc / 24Vac	SG3 cooling request
Block II / DI11	pCOe-1 / J4 / DI3	24Vdc / 24Vac	SG4 heating request
Block II / DI12	pCOe-1 / J4 / DI4	24Vdc / 24Vac	SG4 cooling request
Block II / DI13	pCOe-2 / J4 / DI1	24Vdc / 24Vac	SG5 heating request
Block II / DI14	pCOe-2 / J4 / DI2	24Vdc / 24Vac	SG5 cooling request
Block II / DI15	pCOe-2 / J4 / DI3	24Vdc / 24Vac	Smart Grid 1
Block II / DI16	pCOe-2 / J4 / DI4	24Vdc / 24Vac	Smart Grid 1

7.4. Load losses

Evaporator / Condenser

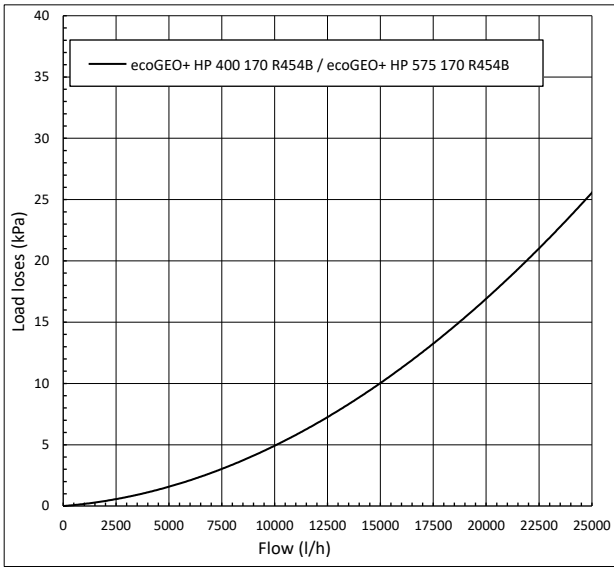

HTR

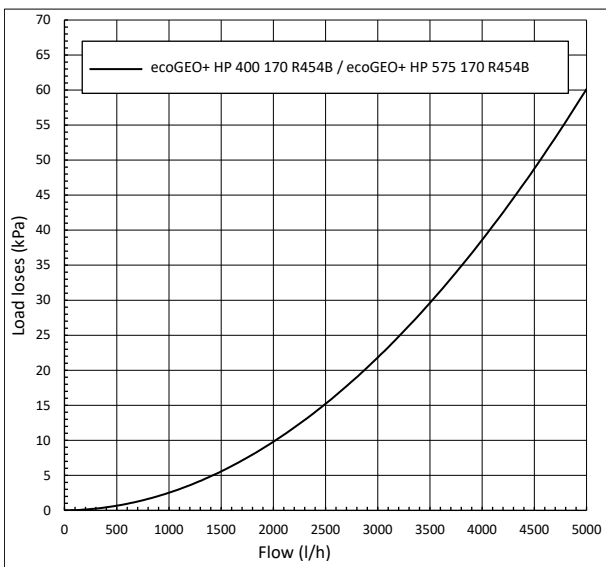

8. Operation map

ecoGEO+ HP1/HP3 400/575 170 R454B

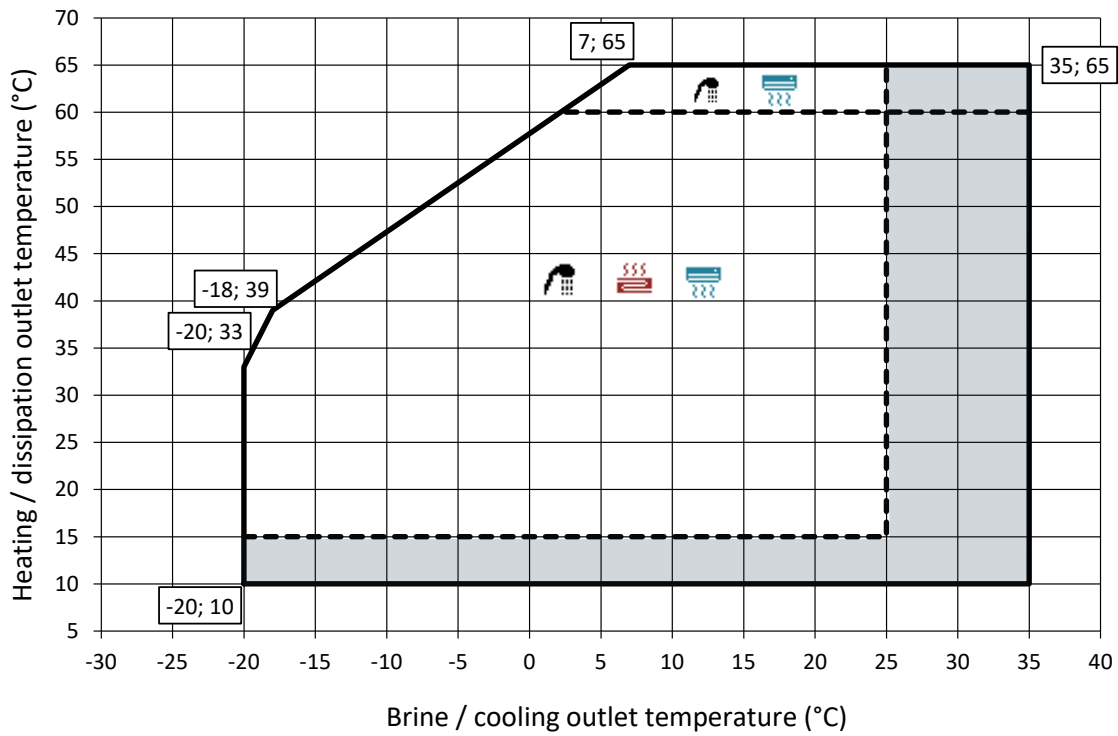

- Map area for use with variable speed circulating pumps, managed by the ecoGEO+ HP heat pump.



NOTE

- Maximum speed of compressor is not able in all the areas of the operation map.

9. Operation curves

9.1. Power and consumption curves

ecoGEO+ HP1/HP3 400/575 170 R454B

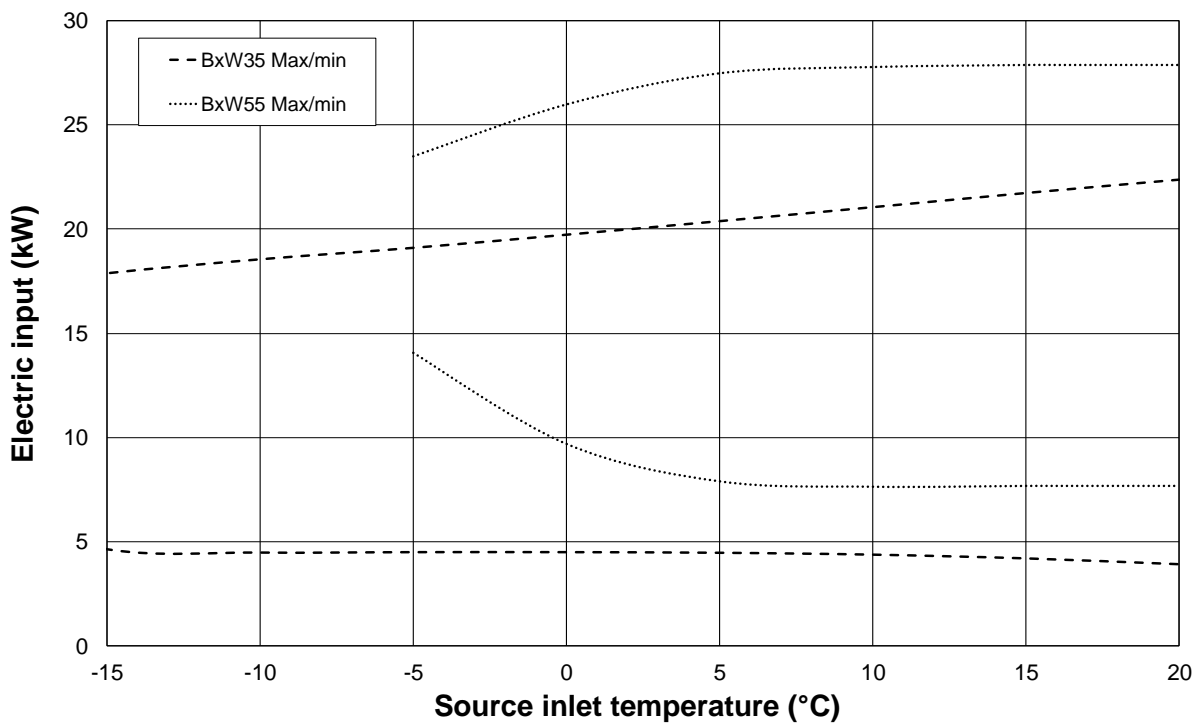
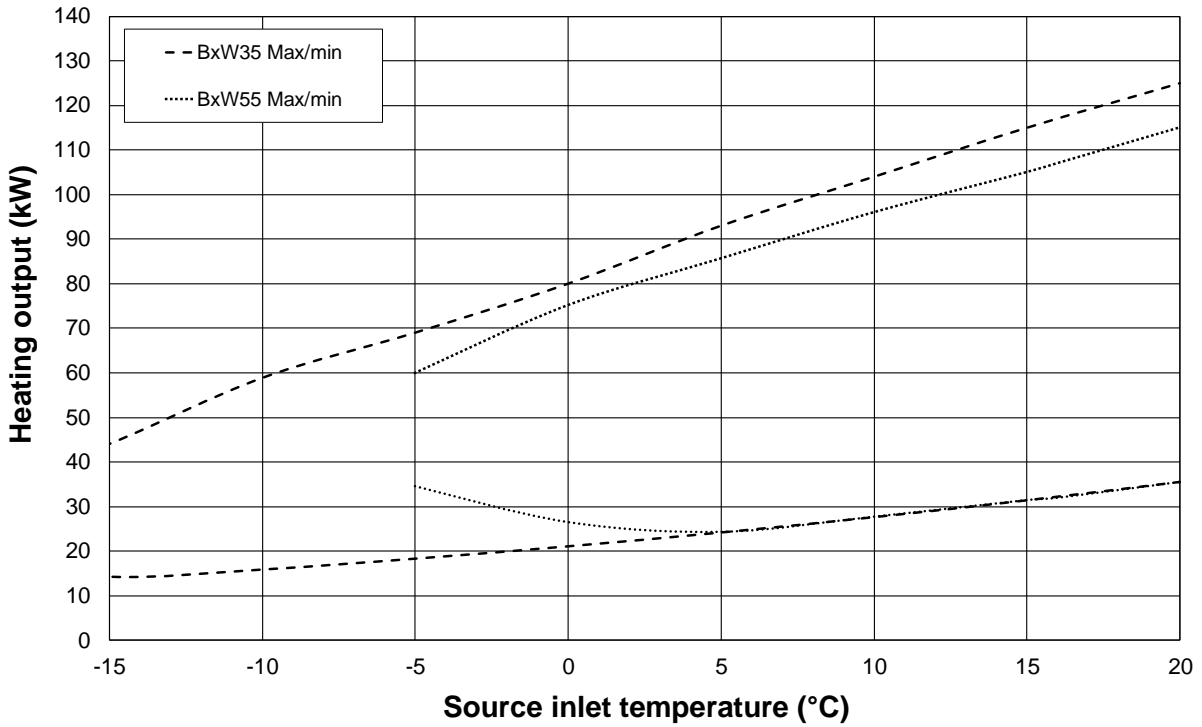

ecoGEO+ HP1/HP3 400/575 170 R454B

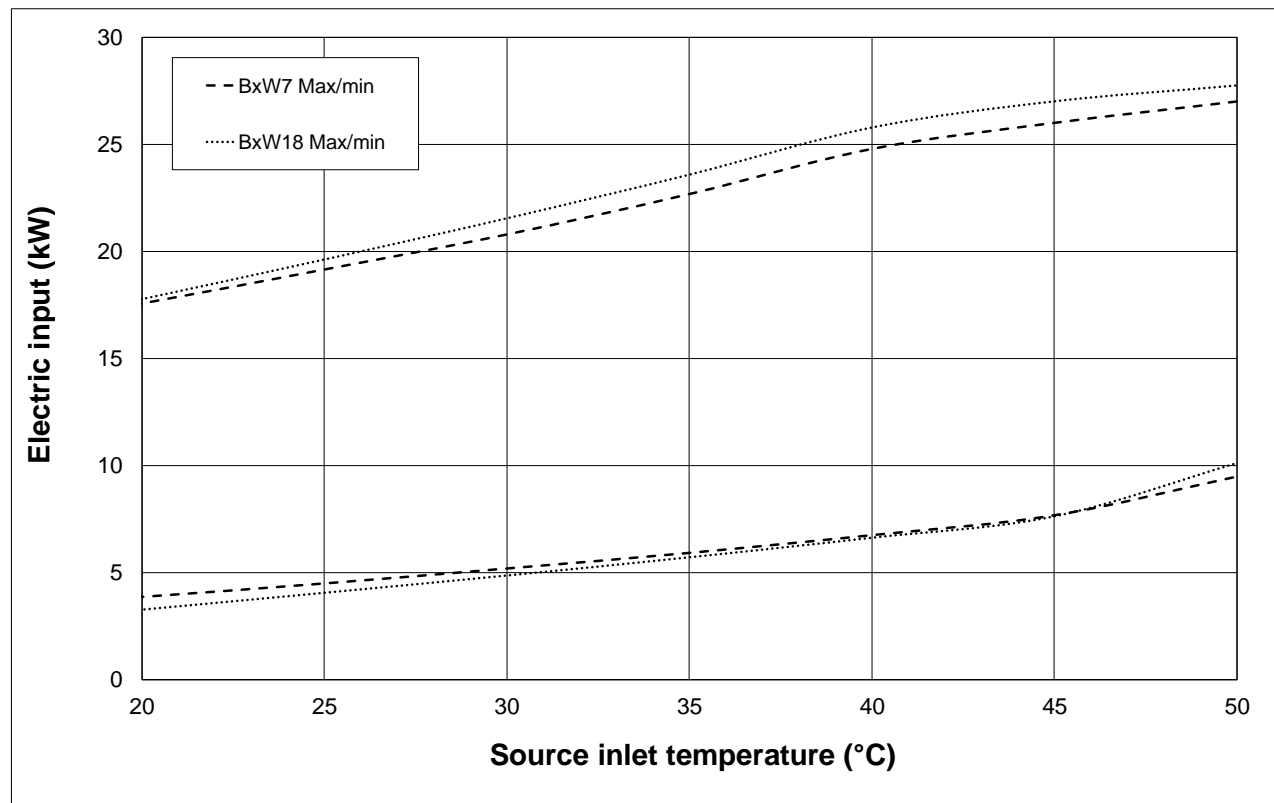
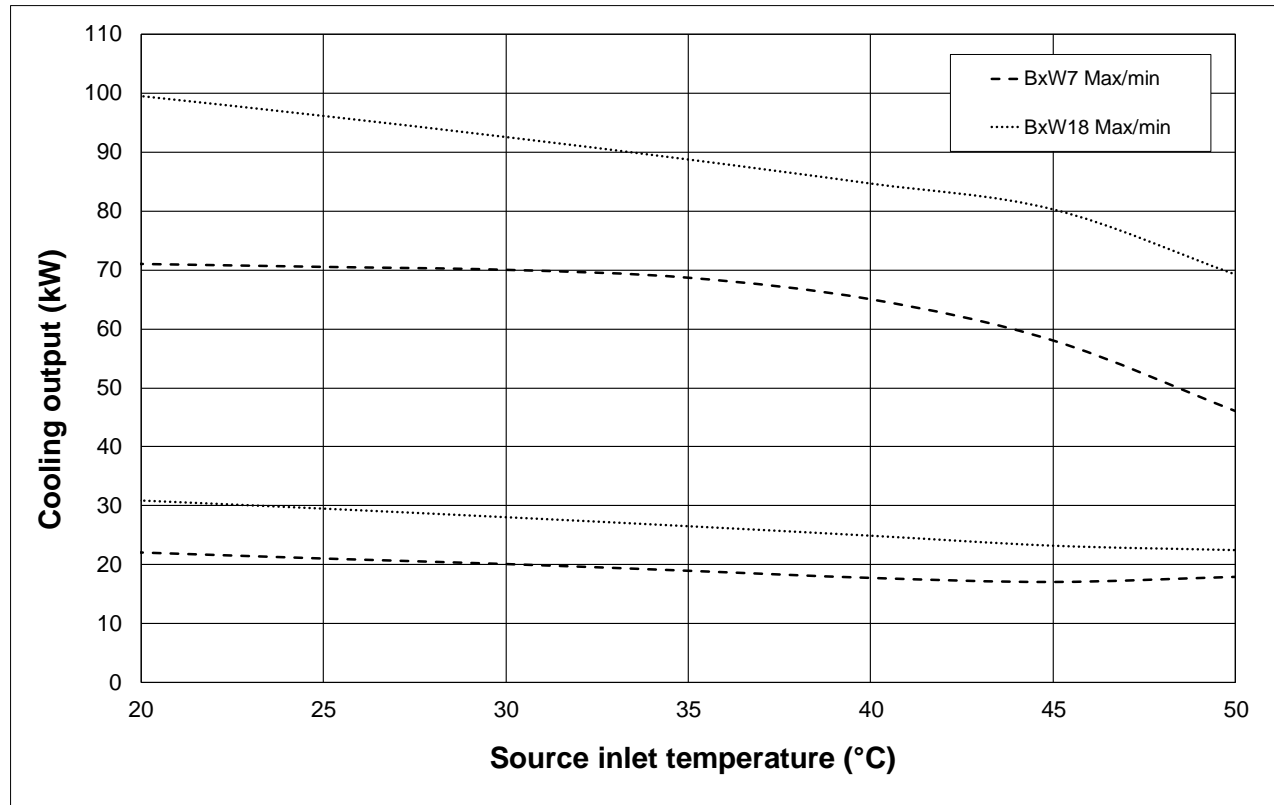

EN

9.2. HTR curves

ecoGEO+ HP1/HP3 400/575 170 R454B

EN

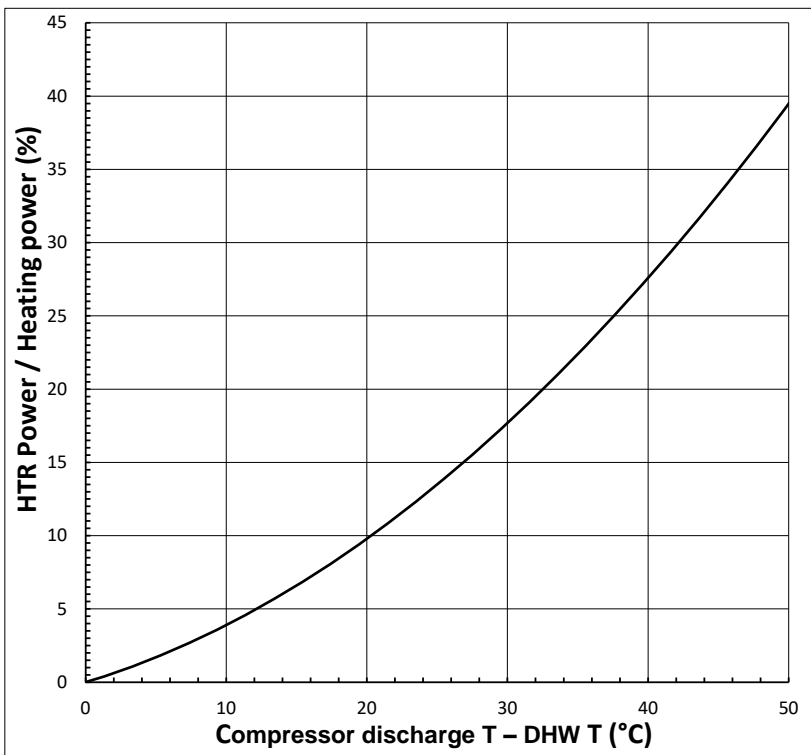
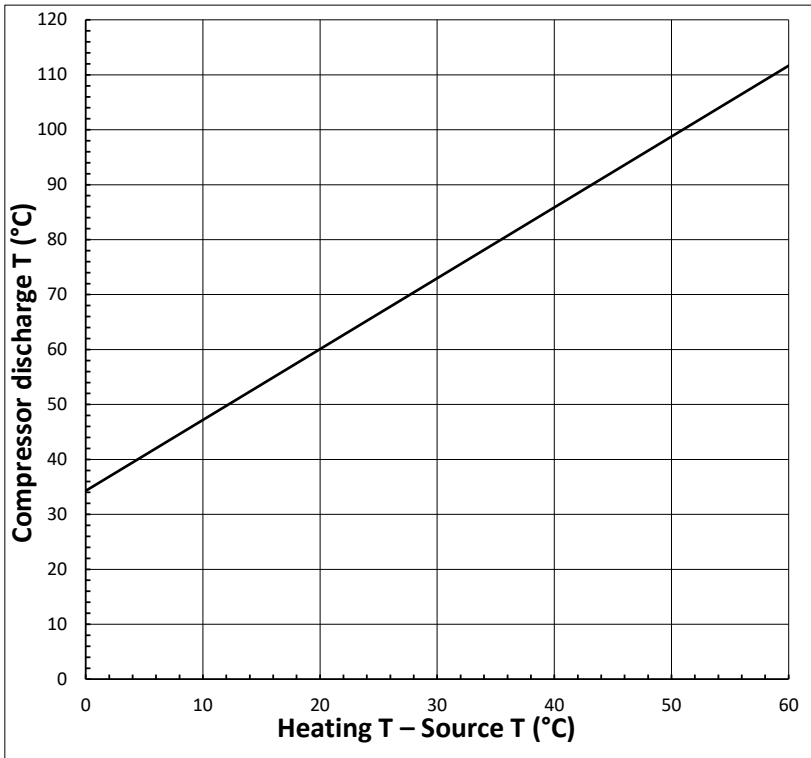

10. Technical data table



























NOTE

- In the technical data tables, you will find a series of numbers in superscript format, the meaning of which is explained below:
 1. In compliance with EN 14511, this includes the consumption of the circulation pumps and the compressor driver.
 2. With variable speed circulating pumps, managed by the ecoGEO+ HP heat pump.
 3. In compliance with EN 12102.
 4. Starting current depends on working condition of the hydraulic circuits.
 5. Maximum consumption can vary significantly according to working conditions, or if the compressor's range of operation is restricted.
 6. The admissible voltage range for proper operation of the heat pump is $\pm 10\%$.
 7. The installation must be carried out in the way that guarantees the nominal flows, which will be calculated for the maximum powers with a temperature differential of 5°C . on the other hand, for the correct start-up of the compressor the installation must guarantee a higher flow rate than that resulting from the formula:
 $Q \geq 1.2 \times \text{Pref}$, where:
 - Q= Flow rate in liters per minute.
 - Pref = Colling capacity at 25% of compressor speed, see operation curves.
 8. Considering support provided by the emergency electrical resistor or the HTR system. Maximum DHW temperature with the HTR system can be limited by the compressor discharge temperature.

Specification ecoGEO+ HP 400 170 R454B (HTR)		Units	HP1 400 170 R454B (HTR)	HP3 400 170 R454B (HTR)
Application	Place of installation		Indoors	
	Type of source system		Geothermal	
	Heating, DHW with external storage tank and pool		✓	
	Integrated active cooling		--	✓
	HTR - High temperature recovery system ⁸ (optional)		✓	✓
	Passive cooling control (External installation)		✓	
Performance	Compressor range of modulation	%	25 - 100	
	Heating power ² , B0W35 ¹⁰	kW	21,1 / 80,0	
	COP _{max} ² / Heating power ² B0W35 ¹⁰	- / kW	4,6 / 32,4	
	Active cooling power ² , B35W7 ¹⁰	kW	--	21,4 / 73,7
	EER ² / Active cooling power ² B35W7 ¹⁰	- / kW	--	4,5 / 22,3
	Maximum DHW temperature without backup	°C	60	
	Maximum DHW temperature with backup ⁸	°C	80	
	Sound power level ³	dBA	59 - 72	
	Energy label / η_s with average temperature control	--	A+++ / 197%	
Operation limits	Heating temperatures / Maximum setpoint	°C	10 - 60 / 60	
	Cooling temperatures / Min. setpoint	°C	-20 - 35 / -15	5 - 35 / 7
	Source heating temperatures	°C	-20 - +35	
	Dissipation cooling temperatures	°C	10 - 60	
	Cooling circuit pressure min / max	bar	2 / 45	
	Heating/cooling circuit pressure	bar	0,7 - 10	
	Source circuit pressure	bar	0,7 - 10	
Working fluids	Refrigerant type / GWP	--	R454B / 466	
	Charge / T CO ₂ eq	Kg/ton	8,2 / 3,82	
	Compressor oil type / amount	l	POE 160SZ / 6,7-7,7	
	Source nominal flow, B0W35 ¹ ($\Delta T = 3 \text{ }^\circ\text{C}$) ⁷	l/h	4612 - 18057	
	Production nominal flow, B0W35 ¹ ($\Delta T = 5 \text{ }^\circ\text{C}$) ⁷	l/h	3572 - 14398	
Electrical data: Controller	1/N/PE 220-240V / 50-60 Hz	-	✓	
	Maximum recommended external protection	A	C1A	
	Transformer primary circuit fuse	A	0,630	
	Transformer secondary circuit fuse	A	4	
Electrical data: Compressor	3/PE 380-480V / 50-60Hz ⁵	--	✓	
	Maximum recommended external recommended ⁶	A	C63A	
	Maximum consumption, B0W35 ¹	kW/A	20,3 / 31,8	
	Maximum consumption, B0W55 ¹	kW/A	29,6 / 45,1	
	Maximum consumption	kW/A	33,7 / 52,9	
	Starting current min/max ⁴	A	10,8 / 16,7	
	Correction of cosine ϕ	--	0,96 - 1	
Dimensions and weight	Height x width x depth	mm	1074x1009x916	
	Empty weight (without assembly)	kg	450	465

Specification ecoGEO+ HP 575 170 R454B (HTR)		Units	HP1 575 170 R454B (HTR)	HP3 575 170 R454B (HTR)
Application	Place of installation		Indoors	
	Type of source system		Geothermal	
	Heating, DHW with external storage tank and pool		✓	
	Integrated active cooling		--	✓
	HTR - High temperature recovery system ⁸ (optional)		✓	✓
	Passive cooling control (External installation)		✓	
Performance	Compressor range of modulation	%	25 - 100	
	Heating power ² , B0W35 ¹⁰	kW	21,1 / 80,0	
	COP _{max} ² / Heating power ² B0W35 ¹⁰	- / kW	4,6 / 32,4	
	Active cooling power ² , B35W7 ¹⁰	kW	--	21,4 / 73,7
	EER ² / Active cooling power ² B35W7 ¹⁰	- / kW	--	4,5 / 22,3
	Maximum DHW temperature without backup	°C	60	
	Maximum DHW temperature with backup ⁸	°C	80	
	Sound power level ³	dBA	59 - 72	
	Energy label / η_s with average temperature control	--	A+++ / 197%	
Operation limits	Heating temperatures / Maximum setpoint	°C	10 - 60 / 60	
	Cooling temperatures / Min. setpoint	°C	-20 - 35 / -15	5 - 35 / 7
	Source heating temperatures	°C	-20 - +35	
	Dissipation cooling temperatures	°C	10 - 60	
	Cooling circuit pressure min / max	bar	2 / 45	
	Heating/cooling circuit pressure	bar	0,7 - 10	
	Source circuit pressure	bar	0,7 - 10	
Working fluids	Refrigerant type / GWP	--	R454B / 466	
	Charge / T CO ₂ eq	Kg/ton	8,2 / 3,82	
	Compressor oil type / amount	l	POE 160SZ / 6,7-7,7	
	Source nominal flow, B0W35 ¹ ($\Delta T = 3 \text{ }^\circ\text{C}$) ⁷	l/h	4612 - 18057	
	Production nominal flow, B0W35 ¹ ($\Delta T = 5 \text{ }^\circ\text{C}$) ⁷	l/h	3572 - 14398	
Electrical data: Controller	1/N/PE 220-240V / 50-60 Hz	-	✓	
	Maximum recommended external protection	A	C1A	
	Transformer primary circuit fuse	A	0,630	
	Transformer secondary circuit fuse	A	4	
Electrical data: Compressor	3/PE 525-600V / 50-60Hz ⁶	--	✓	
	Maximum recommended external recommended ⁶	A	C63A	
	Maximum consumption, B0W35 ¹	kW/A	20,3 / 22,2	
	Maximum consumption, B0W55 ¹	kW/A	29,6 / 32,3	
	Maximum consumption	kW/A	33,7 / 36,8	
	Starting current min/max ⁴	A	7,5 / 11,6	
	Correction of cosine ϕ	--	0,96 - 1	
Dimensions and weight	Height x width x depth	mm	1074x1009x916	
	Empty weight (without assembly)	kg	450	465

11. Symbols

	DHW circuit		3-way valve open/closed
	Pool		3-way thermostatic valve
	Heating system		3-way modulating valve 0-10Vdc
	Cooling system		Check valve
	NTC temperature probe		Cut-off valve
	Relay thermostat		Safety valve
	Data bus communication terminal		Differential pressure valve
	Circulator pump		Particulate filter
	Direct outlet unit		Heat exchanger
	Outlet unit with mixture		Outlet pipe
	Electrical resistance		Return pipe
	Drain defrost heater		Flexible hose
	Expansion vessel		Drain

CE



800791



ECOFORREST GEOTERMIA, S.L.

Parque Empresarial Porto do Molle | Rúa das Pontes, 25 |

36350 – Nigrán – Pontevedra.- (Spain)

Tel.: +34 986 262 184

<http://www.ecoforest.es>