

SIHI^{LPH-X} - Liquid Ring Vacuum Pump

One Stage



SIHI® Pumps

LPH 50523

Pressure Range: 120 to 1013 mbar
Suction Range: 115 to 540 m³/h

CONSTRUCTION

SIHI liquid ring vacuum pumps have a simple but robust construction with the following features and benefits:

- Near isothermal compression
- Oil free, with no internal lubrication
- Capable of handling almost all gases and vapours
- Able to handle quantities of liquid "carry over"
- Low maintenance and safe operation
- Low noise and almost vibration free
- Available in a wide range of materials
- Broad range of applications
- O-ring sealing as standard
- Drain hole as standard
- Built-in solids drain
- Rotating metallic parts are non contacting to minimise wear
- ATEX compliance

SIHI liquid ring vacuum pumps of the range LPH 50523 are one stage pumps. They can be used as compressors without any modification.

APPLICATIONS

Evacuation and pumping of dry gases and saturated vapours. The pumps can also handle liquids. These units offer pressures in the range of 120...900 mbar(a) to atmospheric. Typical application areas include:

- Chemical and pharmaceutical industry for distillation, drying and degassing.
- Electronic industry for impregnation and drying.
- Plastics & Rubber industry for degassing.



NOTE

By continuously feeding the pump with a small amount of service liquid (usually water), the heat due to gas/vapour compression is conducted away. This also replenishes the liquid ring and ensures that it does not become saturated with process media. The condensed gas and fluid can be separated in a liquid separator (see Accessories Catalogue). Recharging the pump with service liquid at ambient temperature enables the unit to condense evacuated gases/vapours. It can therefore be used for solvent recovery. More information is provided in the accessory catalogues. The integrated solids drain permits the removal of any entrained solids whilst the pump is operating. The service liquid can, therefore, simply be re-circulated. The rotation of the pump is clockwise when viewed from the drive end.

GENERAL TECHNICAL DATA

Pump Type	Units	LPH 50523
Speed	50 Hz 60 Hz	rpm 1450 1740
Maximum overpressure on compression	bar	1.5
Permissible pressure difference between suction and discharge side	max. min.	1.5 0.2
Hydraulic test pressure (overpressure)	bar	3.0
Moment of inertia of rotating parts of pump and water content	kg · m ²	0.25
Noise level at 200 mbar suction pressure [50Hz]	dB (A)	68
Minimum permissible pulley diameter for V belt drive	mm	200 or 250 ¹⁾
Maximum gas temperature:	dry saturated	°C °C 200 100
Service liquid:		
Maximum permissible temperature	°C	80
Minimum permissible temperature	°C	10
Maximum viscosity	mm ² /s	90
Maximum density	kg/m ³	1200
Liquid capacity up to middle of shaft	litre	12.0
Maximum flow resistance of the heat exchanger	bar	0.2

In selecting a pump, avoid choosing one which is likely to be operating at a combination of its maximum permissible limits e.g. maximum viscosity and maximum permissible pressure difference.

¹⁾ at 60Hz

Materials

Position number	COMPONENT	MATERIALS		
		0K	0E	4B
10.10	Vacuum casing	0.6025		1.4408
10.90	Central body			
13.70	Guide disc			1.4404
21.00	Shaft	1.4021		1.4401
23.50	Impeller	1.4308	1.4408	1.4517
43.30, 43.31	Mechanical seal, Type SIHI FK (AG●)	Cr-Steel / Carbon / Butadiene rubber		Cr Ni Mo-Steel / Carbon / Viton
43.30, 43.31	Double mechanical seal	materials on request		
46.10	Gland packing	GORE	-	

Cut-away diagram LPH 50523 with single, double mechanical seal and gland packing

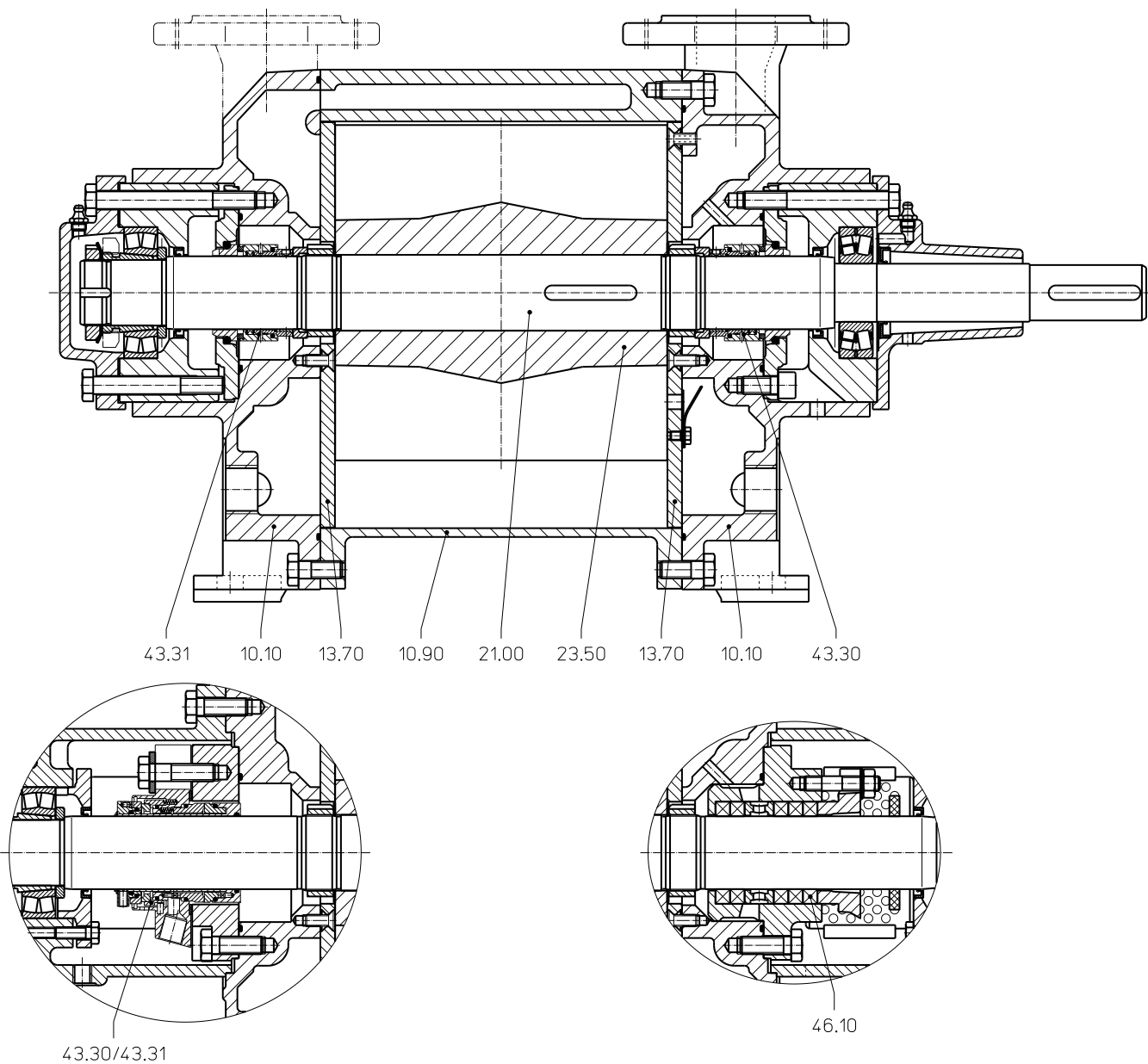

Performance Characteristics LPHX 50523

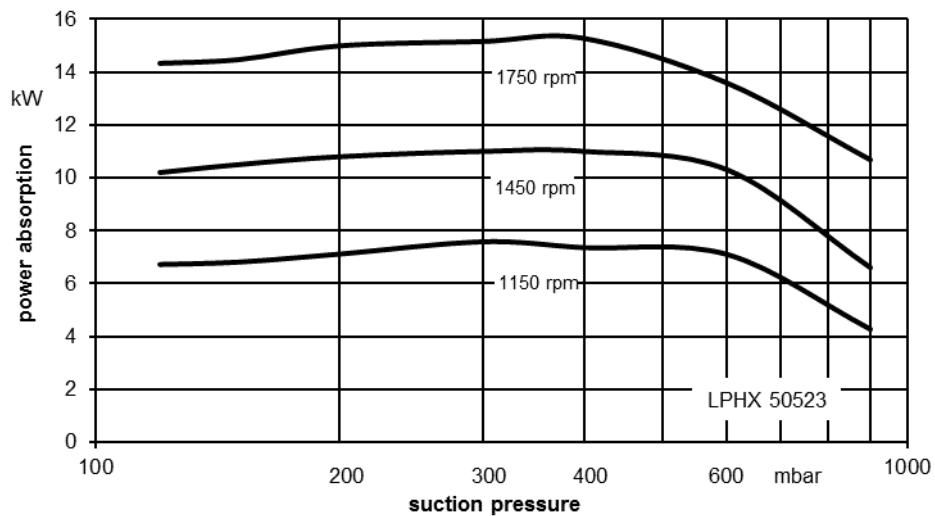
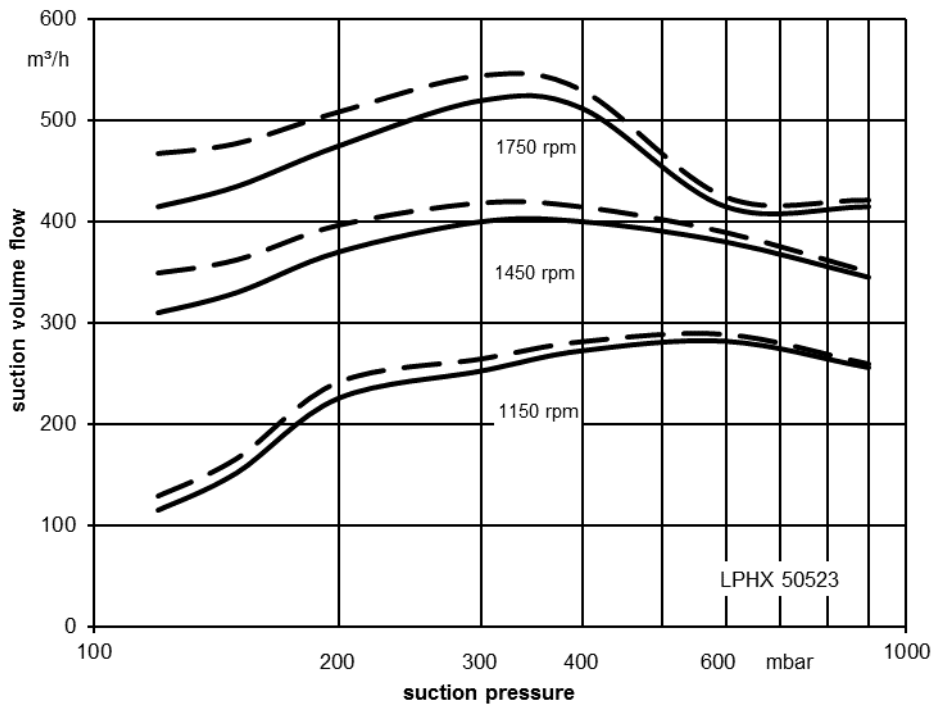

The operating data is valid under the following conditions:

- Process media:
 - dry air: 20°C —————
 - steam saturated air: 20°C - - - - -

- Service liquid:
 - water: 15°C

Pressure of gas to be evacuated: 1013 mbar (Atmospheric pressure)

The suction volume is related to the suction pressure.

Tolerance for the suction volume flow is 10% and for power 5%.

The maximum consumption of make up water occurs at the lowest suction pressure.

SIHI^{LPH-X}

Dimensions LPH 50523 with single mechanical seal and gland packing

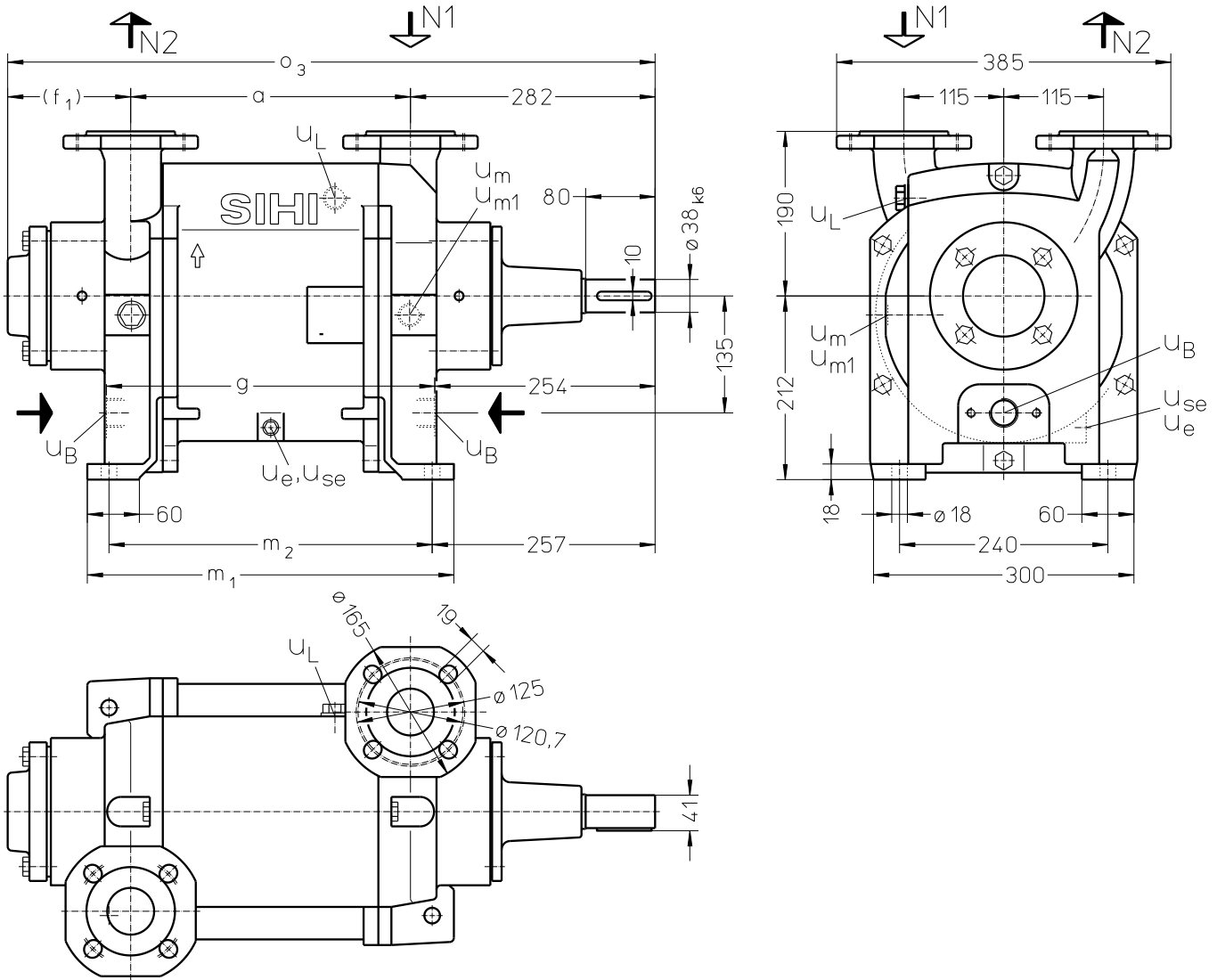

- N 1 = Gas-inlet DN 50 (according to DIN EN 1092 PN 10)
Gas-inlet 2" (according to ANSI 150 lbs)
- N 2 = Gas-outlet DN 50 (according to DIN EN 1092 PN 10)
Gas-outlet 2" (according to ANSI 150 lbs)
- U_B = Connection for service liquid G 1
- U_e = Connection for drain G $\frac{1}{4}$ *
- U_{se} = Connection for dirt drain G $\frac{1}{4}$ *
- U_L = Connection for air cock G $\frac{3}{4}$
- U_m = Connection for pressure gauge G $\frac{3}{4}$
- U_{m1} = Connection for drainage valve or liquid level sensor G $\frac{3}{4}$

* U_e, U_{se} = G $\frac{1}{2}$ for stainless steel execution

	execution	a [mm]	f_1 [mm]	g [mm]	m_1 [mm]	m_2 [mm]	o_3 [mm]	approx. weight [kg]
LPH 50523	mechanical seal	322	142	378	422	372	746	160
	gland packing		219				823	

LPH 50523 with single mechanical seal, gland packing and Top-Mounted Liquid Separator

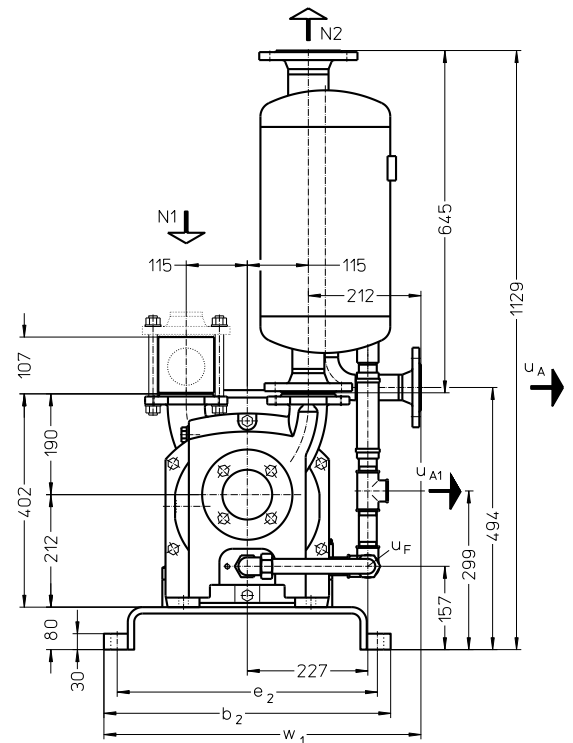
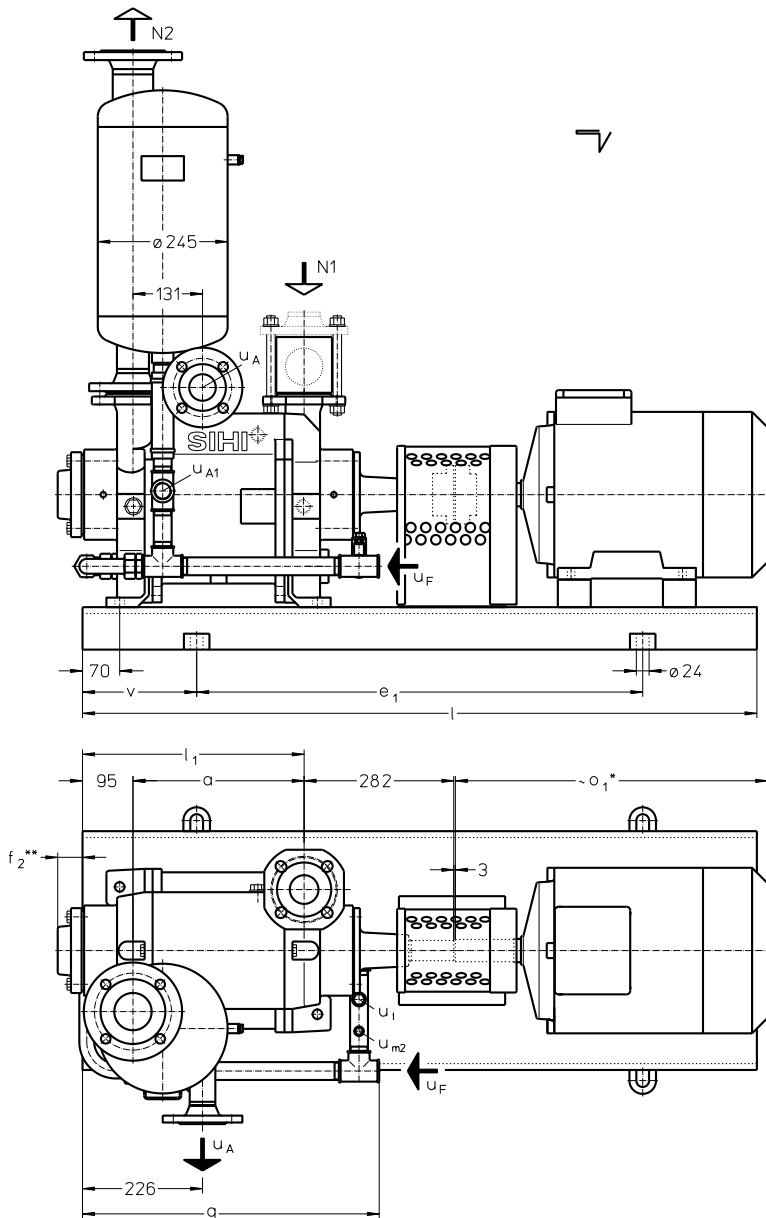

- N 1 = Gas inlet DN 50
- N 2 = Gas outlet DN 65 (4 bolt)
- U_A = Liquid drain DN 40
- U_{A1} = Liquid drain G 1
- U_F = Connection for make up water G 1
- U_{m2} = Connection for pressure gauge G 1/4
- U_t = Connection for thermometer G 1/2

	E-Motor 50 Hz			base-plate	a [mm]	b ₂ [mm]	e ₁ [mm]	e ₂ [mm]	f ₂ ^{**} [mm]	l [mm]	l ₁ [mm]	o ₁ [*] [mm]	q [mm]	v [mm]	w ₁ [mm]	approx. weight [kg]
	size	IP 55	kW EEx e II T3													
LPH 50523	160 M	11.0	-	S436	322	540	840	490	47	1270	417	588	559	215	597	345
	160 L	-	13.5									628				385

* Dimensions dependent upon motor supplier
 ** Dimension +77mm at execution with gland packing

Flange dimensions according to DIN EN 1092 PN 10 [mm]			
DN	40	50	65
k	110	125	145
D	150	165	185
Number x d ₂	4 x 18	4 x 18	4 x 18

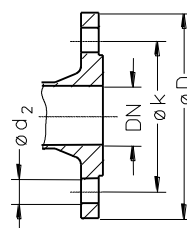

LPH 50523 with single mechanical seal, gland packing and Side-Mounted Liquid Separator

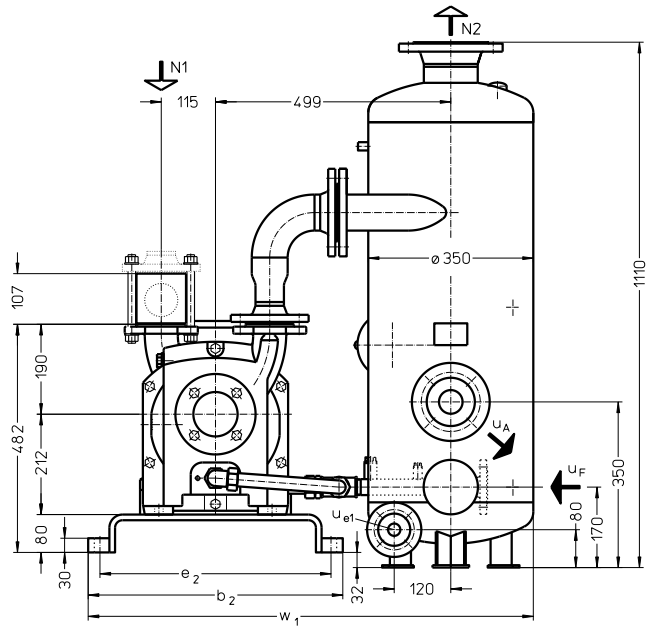
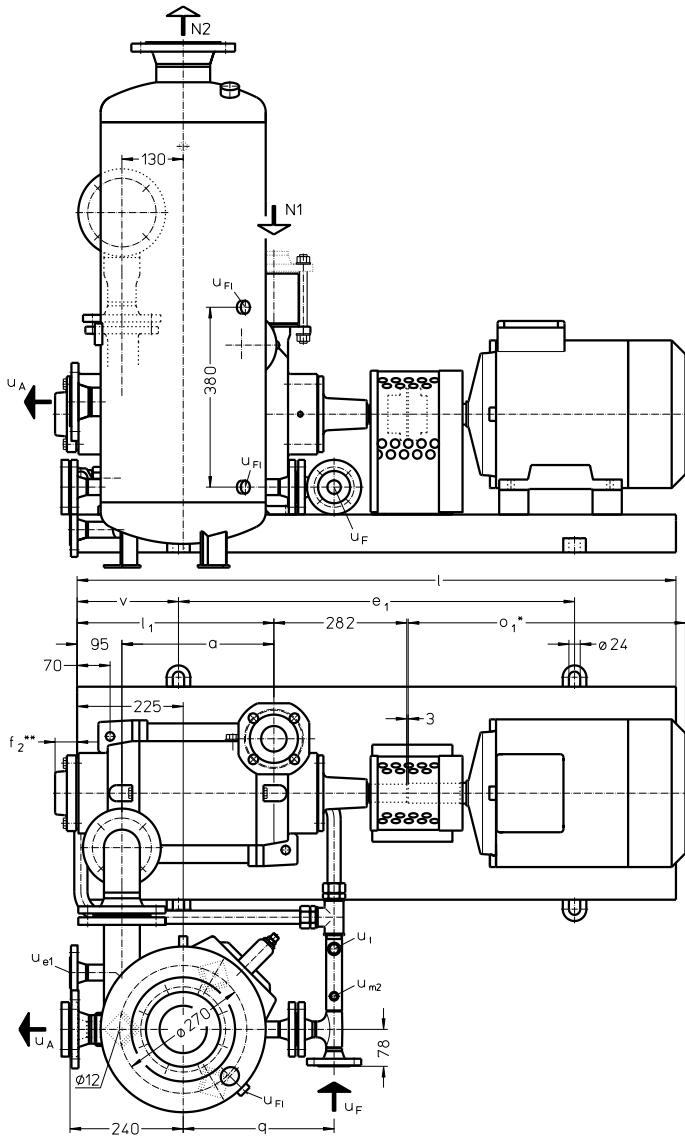

- N 1 = Gas-inlet DN 50
- N 2 = Gas-outlet DN 100
- U_A = Liquid drain DN 50
- U_{e1} = Connection for drain DN 25
- U_F = Connection for make up water DN 25
- U_{FI} = Connection for liquid level indicator G 1/2
- U_{m2} = Connection for pressure gauge G 1/4
- U_t = Connection for thermometer G 1/2

	E-Motor 50 Hz			base-plate	a [mm]	b ₂ [mm]	e ₁ [mm]	e ₂ [mm]	f ₂ ** [mm]	l [mm]	l ₁ [mm]	o ₁ * [mm]	q [mm]	v [mm]	w ₁ [mm]	approx. weight [kg]
	size	IP 55	kW EEx e II T3													
LPH	160 M	11.0	-	S436	322	540	840	490	47	1270	417	588	320	215	944	385
50523	160 L	-	13.5									628				430

* Dimensions dependent upon motor supplier

** Dimension +77mm at execution with gland packing

Flange dimensions according to DIN EN 1092 PN 10 [mm]			
DN	25	50	100
k	85	125	180
D	115	165	220
Number x d ₂	4 x 14	4 x 18	8 x 18

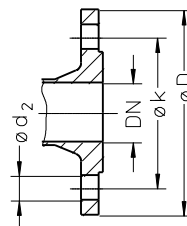

Make-up Liquid Consumption in [m³/h] dependent upon suction pressure, speed, drive type and temperature difference.

Suction Pressure [mbar]		120 (150)				400				600				800							
Pump type	Speed [rpm]	KB				FB	KB				FB	KB				FB	KB				FB
		Temperature Difference °C					Temperature Difference °C					Temperature Difference °C					Temperature Difference °C				
		20	10	5	2		20	10	5	2		20	10	5	2		20	10	5	2	
LPH 50523	1150	0.27	0.51	0.89	1.63	3.6	0.27	0.55	0.94	1.64	3.3	0.27	0.49	0.82	1.37	2.5	0.18	0.31	0.49	0.76	1.2
	1450	0.40	0.72	1.20	2.0		0.42	0.75	1.22	1.96		0.38	0.65	1.04	1.60		0.25	0.41	0.61	0.86	
	1750	0.53	0.93	1.47	2.28		0.56	0.96	1.48	2.22		0.47	0.80	1.21	1.75		0.30	0.49	0.69	0.93	

FB = Total service liquid flow rate on once-through system

KB = Flow of make-up water when combined with partial recirculation liquid at a temperature of 20°C, 10°C, 5°C, 2°C warmer than make-up water.

Product Code - order details

Range + Size	Hydraulic + Bearings	Shaft Seal	Materials	Casing Sealing
	<ul style="list-style-type: none"> •A 1. hydraulic •B two greased roller bearings 	041 Gland packing AGE Mechanical seal type SIHI FK, O-rings butadiene rubber AG1 Mechanical seal type SIHI FK, O-rings Viton	0K Main parts out of cast iron (GG), and impeller in low alloyed steel 0E Similar to 0K, but impeller in stainless steel 4B Main parts out of stainless steel	1 O-ring sealing
LPH 50523	AB	041 AGE AG1	0K 0K, 0E 4B	1

Motor Selection

For our products we offer a lot of different motor types.
To identify the right motor please specify frequency, voltage and protection class.

Example of an Order:

LPHX 50523 AB AGE 0K 1 with 11.0 kW AC motor, 50 Hz, 400V Δ, IP55

Spare Parts Order Number

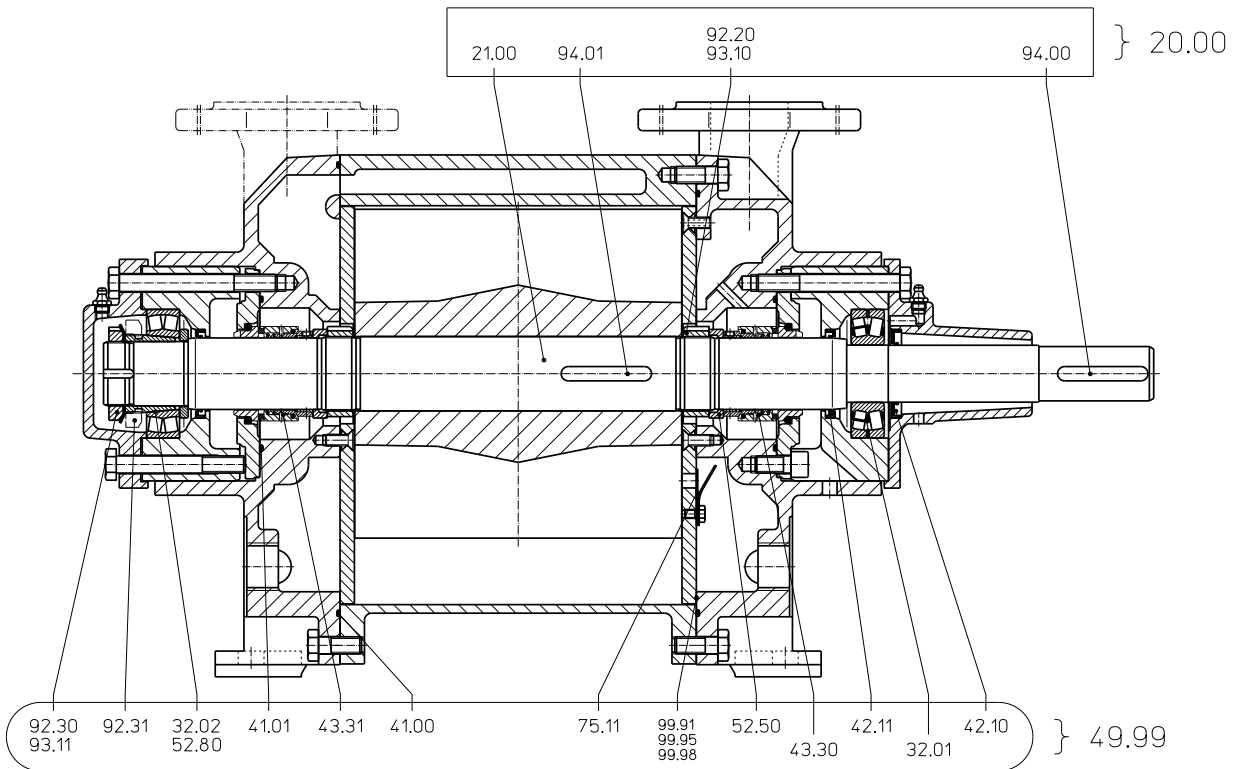

Material Design 0K, 0E		
Group	Spare parts kit	LPH 50523
20.00	Shaft	65 007 894
49.99	Basic repair AGE	65 007 895

Material Design 4B		
Group	Spare parts kit	LPH 50523
20.00	Shaft	65 007 912
49.99	Basic repair AG1	65 007 913

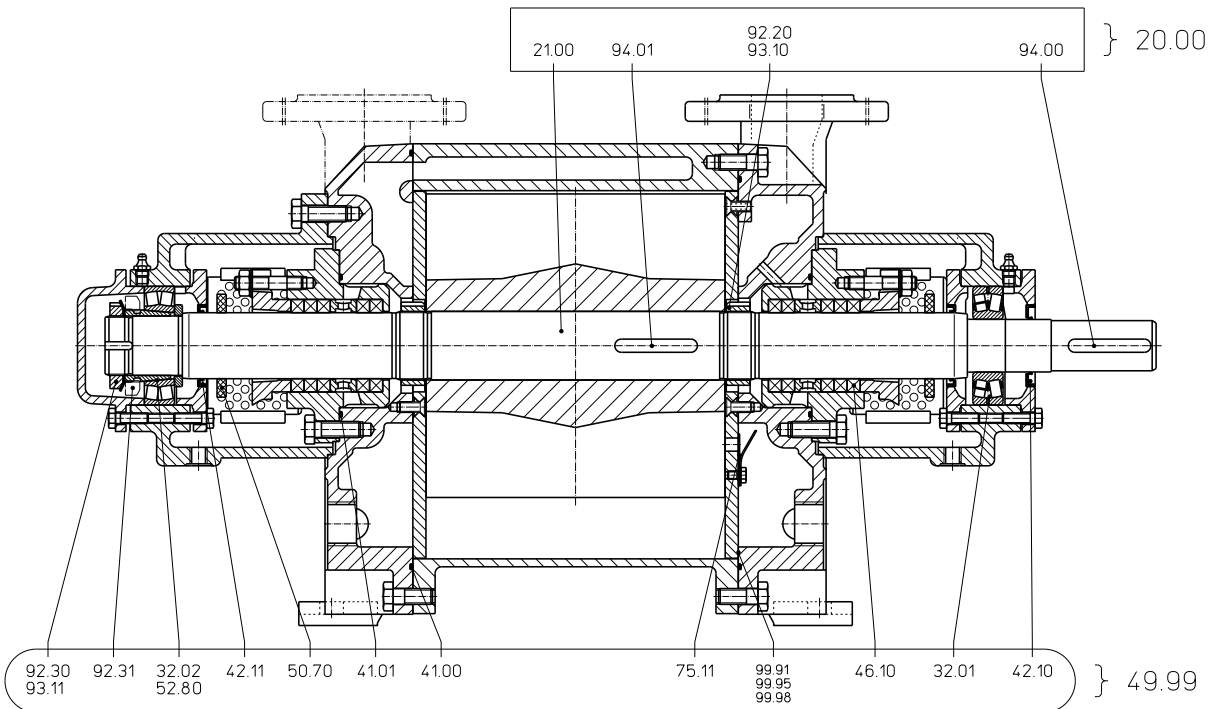

Material Design 0K		
Group	Spare parts kit	LPH 50523
20.00	Shaft	65 007 933
49.99	Basic repair 041	65 007 934

Accessories

Recommended Accessory	Material Execution		LPH 50523
Top Mounted Liquid Separator			Type / Weight
Top mounted separator	1.4571	SIHI-Part No.	XBa 2041 / 23 kg 35 000 420
Service liquid pipework, standard execution	Steel 1.4571	SIHI-Part No.	35 030 015 35 030 016
Service liquid pipework with thermostatic control	Steel + Brass 1.4571 + Brass	SIHI-Part No.	20 073 159 20 073 160
Side Mounted Liquid Separator			Type / Weight
Side mounted separator	1.4571	SIHI-Part No.	XBp 912 / 51 kg 35 000 535
Service liquid pipework, standard execution	Steel 1.4571	SIHI-Part No.	35 030 030 35 030 031
Service liquid pipework with thermostatic control	Steel + Brass 1.4571 + Brass	SIHI-Part No.	20 073 283 20 073 284
Pressure pipework (bend)	1.0254 1.4571	SIHI-Part No.	35 003 207 35 003 208
Liquid level indicator	Brass + Plexiglas 1.4571 + Plexiglas	SIHI-Part No.	43 014 912 43 040 384
Sterling SIHI - Non Return Ball Valve			
Intermediate flange execution XCk 50	0.6025 + Butadiene rubber 0.6025 + Teflon 1.4408 + Teflon	SIHI-Part No. Weight	20 072 792 / 3.6 kg 20 072 791 / 3.8 kg 20 029 498 / 10.8 kg
Flange execution with glass cylinder XCk 506	0.6025 + Butadiene rubber 0.6025 + Teflon 1.4408 + Teflon	SIHI-Part No. Weight	20 072 838 / 8.5 kg 20 072 849 / 8.5 kg 20 072 837 / 8.5 kg
Adapter Flange	Steel 1.4571	SIHI-Part No.	43 076 093 43 078 488
Drain Valve XCg 015	Steel + Teflon 1.4571 + Teflon	SIHI-Part No.	43 166 248 43 014 547
Double nipple ^{3/4"} - ^{1/2"}	Steel 1.4571	SIHI-Part No.	43 013 096 43 013 097
Air Inlet Valve + Double nipple	Brass 1.4408	SIHI-Part No.	43 045 945 + 43 013 090 43 053 736 + 43 013 091
Motor standard execution IP 55		Size Power Weight	160 M 11.0 kW 73 kg
Coupling for motor IP 55 Pump side Motor side		Type / Weight SIHI-Part No.	B 110 / 3.9 kg 43 021 446 43 021 448
Coupling guard ¹⁾ Coupling guard ²⁾	Steel Steel	SIHI-Part No. SIHI-Part No.	43 042 306 43 042 269
Motor in EEx e II T3 execution		Size Power Weight	160 L 13.5 kW 107 kg
Coupling for motor EEx e II T3 Pump side Motor side		Type / Weight SIHI-Part No.	BDS 135 / 6.6 kg 43 111 062 43 111 072
Coupling guard ¹⁾ Coupling guard ²⁾	Brass Brass	SIHI-Part No. SIHI-Part No.	43 042 307 43 042 305
Baseplate	Steel	Type / Weight SIHI-Part No.	S 436 / 71 kg 43 040 641

¹⁾ execution with mechanical seal

²⁾ execution with gland packing

Designs subject to change without prior notice.