

Reflexomat Touch

RS 90/1 T, RS 150/1 T, RS 300/1 T, RS 400/1 T, RS 580/1 T
RS 90/2 T, RS 150/2 T, RS 300/2 T, RS 400/2 T, RS 580/2 T
external air T

GB Operating manual

Original operating manual

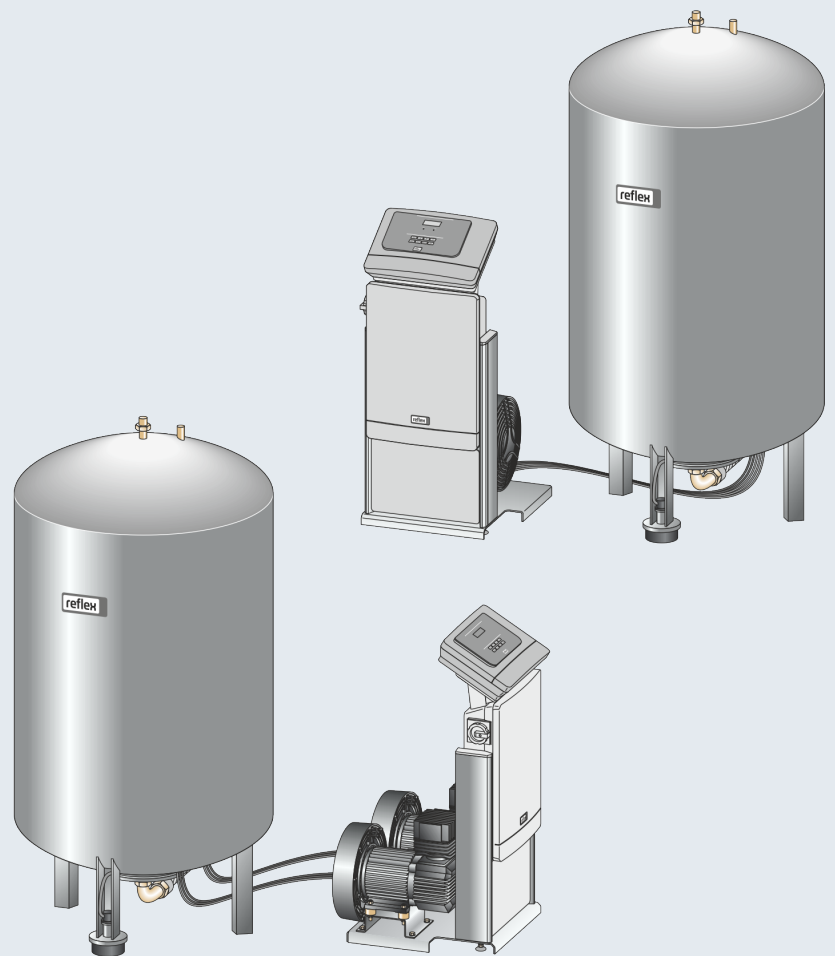

1	Notes on the operating manual	3
2	Liability and guarantee	3
3	Safety	3
3.1	Explanation of symbols.....	3
3.1.1	Symbols and notes used	3
3.2	Personnel requirements	3
3.3	Personal protective equipment	3
3.4	Intended use	3
3.5	Inadmissible operating conditions.....	3
3.6	Residual risks.....	3
4	Description of the device	4
4.1	Description.....	4
4.2	Overview	4
4.3	Identification.....	4
4.3.1	Nameplate.....	4
4.3.2	Type code	5
4.4	Function	5
4.5	Scope of delivery	5
4.6	Optional equipment and accessories.....	5
5	I/O module (optional expansion module)	6
5.1	Technical data.....	6
5.2	Settings.....	6
5.2.1	Terminator settings in RS-485 networks.....	6
5.2.2	Setting the module address	7
5.2.3	I/O module default settings.....	7
5.3	Replacing the fuses	8
6	Technical data.....	8
6.1	Control unit.....	8
6.2	Tanks.....	8
7	Installation	9
7.1	Installation conditions	9
7.1.1	Incoming inspection	9
7.2	Preparatory work.....	9
7.3	Execution.....	10
7.3.1	Positioning	10
7.3.2	Tank installation	10
7.3.3	Connection to the facility system	10
7.3.4	Connection to an external compressed air line.....	11
7.3.5	Fitting the level sensor.....	12
7.4	Make-up and degassing variants.....	12
7.4.1	Function.....	12
7.5	Electrical connection.....	13
7.5.1	Terminal plan, connection component.....	13
7.5.2	Terminal plan, operating unit	14
7.5.3	RS-485 interface	14
7.6	Installation and commissioning certificate	15
8	Commissioning	15
8.1	Checking the requirements for commissioning.....	15
8.2	Reflexomat switching points	15
8.3	Modifying the controller's start routine.....	15
8.4	Venting the vessels	16
8.5	Filling the tanks with water	16
8.6	Starting Automatic mode.....	17
9	Operation	17
9.1	Operating modes	17
9.1.1	Automatic mode.....	17
9.1.2	Manual mode.....	17
9.1.3	Stop mode.....	17
10	Controller.....	17
10.1	Operator panel	17
10.2	Calibrating the touch screen.....	18
10.3	Configuring settings in the controller	18
10.3.2	Default settings	19
10.3.3	Messages.....	19
11	Maintenance	21
11.1	Maintenance schedule.....	21
11.2	Checking switching points	21
11.3	Cleaning	22
11.3.1	Cleaning the tanks.....	22
11.3.2	Cleaning the dirt trap	22
11.4	Inspection	22
11.4.1	Pressure-bearing components.....	22
11.4.2	Inspection prior to commissioning.....	22
11.4.3	Inspection intervals.....	22
12	Disassembly.....	23
13	Annex.....	23
13.1	Reflex Customer Service	23
13.2	Conformity and standards.....	23
13.3	Guarantee	23

1 Notes on the operating manual

This operating manual is an important aid for ensuring the safe and reliable functioning of the device.

Reflex Winkelmann GmbH accepts no liability for any damage resulting from failure to observe the information in this operating manual. In addition to the requirements set out in this operating manual, national statutory regulations and provisions in the country of installation must also be complied with (concerning accident prevention, environment protection, safe and professional work practices, etc.).

This operating manual describes the device with basic equipment and interfaces for optional equipment with additional functions.

▶ **Notice!**

Every person installing this equipment or performing any other work at the equipment is required to carefully read this operating manual prior to commencing work and to comply with its instructions. The manual is to be provided to the product operator and must be stored near the product for access at any time.

2 Liability and guarantee

The device has been built according to the state of the art and recognised safety rules. Nevertheless, its use can pose a risk to life and limb of personnel or third persons as well as cause damage to the system or other property.

It is not permitted to make any modifications at the device, such as to the hydraulic system or the circuitry.

The manufacturer shall not be liable nor shall any warranty be honoured if the cause of any claim results from one or more of the following causes:

- Improper use of the device.
- Unprofessional commissioning, operation, service, maintenance, repair or installation of the device.
- Failure to observe the safety information in this operating manual.
- Operation of the device with defective or improperly installed safety/protective equipment.
- Failure to perform maintenance and inspection work according to schedule.
- Use of unapproved spare parts or accessories.

Prerequisite for any warranty claims is the professional installation and commissioning of the device.

▶ **Note!**

Arrange for Reflex Customer Service to carry out commissioning and annual maintenance, see chapter 13.1 "Reflex Customer Service" on page 23.

3 Safety

3.1 Explanation of symbols

3.1.1 Symbols and notes used

The following symbols and signal words are used in this operating manual.

⚠ DANGER

Danger of death and/or serious damage to health

- The sign, in combination with the signal word 'Danger', indicates imminent danger; failure to observe the safety information will result in death or severe (irreversible) injuries.

⚠ WARNING

Serious damage to health

- The sign, in combination with the signal word 'Warning', indicates imminent danger; failure to observe the safety information can result in death or severe (irreversible) injuries.

⚠ CAUTION

Damage to health

- The sign, in combination with the signal word 'Caution', indicates danger; failure to observe the safety information can result in minor (reversible) injuries.

ATTENTION

Damage to property

- The sign, in combination with the signal word 'Attention', indicates a situation where damage to the product itself or objects within its vicinity can occur.

▶ **Note!**

This symbol, in combination with the signal word 'Note', indicates useful tips and recommendations for efficient handling of the product.

3.2 Personnel requirements

Assembly, commissioning and maintenance as well as connection of the electrical components may only be carried out by knowledgeable and appropriately qualified electricians.

3.3 Personal protective equipment



Use the prescribed personal protective equipment as required (e.g. ear protection, eye protection, safety shoes, helmet, protective clothing, protective gloves) when working on the system.

Information on personal protective equipment requirements is set out in the relevant national regulations of the respective country of operation.

3.4 Intended use

The device is a pressure maintaining station for heating and cooling water systems. It is used to maintain the water pressure and to add water within a system. The devices may be used only in systems that are sealed against corrosion and with the following water types:

- Non-corrosive
- Chemically non-aggressive
- Non-toxic

The ingress of atmospheric oxygen by permeation into the entire heating and cooling water system, make-up water and similar must be reliably minimized during operation.

3.5 Inadmissible operating conditions

The device is not suitable for the following applications:

- Mobile system operation.
- Outdoor operation.
- For use with mineral oils.
- For use with flammable media.
- For use with distilled water.

▶ **Note!**

It is not permitted to make any modifications to the hydraulic system or the circuitry.

3.6 Residual risks

This device has been manufactured to the current state of the art. However, some residual risk cannot be excluded.

⚠ CAUTION

Risk of burns on hot surfaces

Hot surfaces in heating systems can cause burns to the skin.

- Wear protective gloves.
- Please place appropriate warning signs in the vicinity of the device.

⚠ CAUTION

Risk of injury due to pressurised liquid

If installation, removal or maintenance work is not carried out correctly, there is a risk of burns and other injuries at the connection points, if pressurised hot water or hot steam suddenly escapes.

- Ensure proper installation, removal or maintenance work.
- Ensure that the system is de-pressurised before performing installation, removal or maintenance work at the connection points.

⚠ WARNING

Risk of injury due to heavy weight

The devices are heavy. Consequently, there is a risk of physical injury and accidents.

- Use suitable lifting equipment for transportation and installation.

4 Description of the device

4.1 Description

The Reflexomat is a pressurisation station for heating and cooling water systems. The Reflexomat essentially comprises a controller and at least one expansion vessel. The expansion vessel is fitted with a diaphragm to divide the vessel into an air space and a water space, preventing the ingress of atmospheric oxygen into the expansion vessel.

The Reflexomat provides the following safety features:

- Optimisation of pressurisation and make-up.
 - No direct intake of air thanks to a regulation of the pressurisation and optional automatic make-up.
 - No circulation issues caused by free bubbles in the circuit water.
 - Reduced corrosion damage due to oxygen removal from make-up water.

Reflexomat with touch control and one compressor

- One "RG" primary vessel as expansion vessel.
- Touch control with one compressor as stand-alone console.

Note!

The connection of "RF" secondary vessels to the "RG" primary vessel is optionally possible.

Reflexomat with touch control and two compressors

- One "RG" primary vessel as expansion vessel.
- Touch control with two compressors as stand-alone console.

Note!

The connection of "RF" secondary vessels to the "RG" primary vessel is optionally possible.

4.2 Overview

Reflexomat with touch control and one compressor

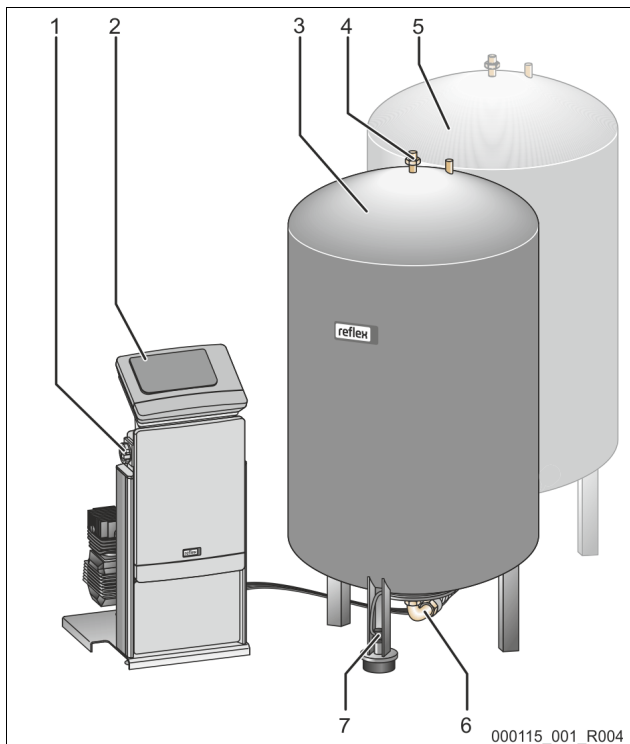

1	Main switch
2	Control unit
3	"RG" primary vessel
4	"SV" safety valve

5	"RF" secondary vessel (optional)
6	"EC" expansion line
7	"LIS" level sensor

Reflexomat with touch control and two compressors

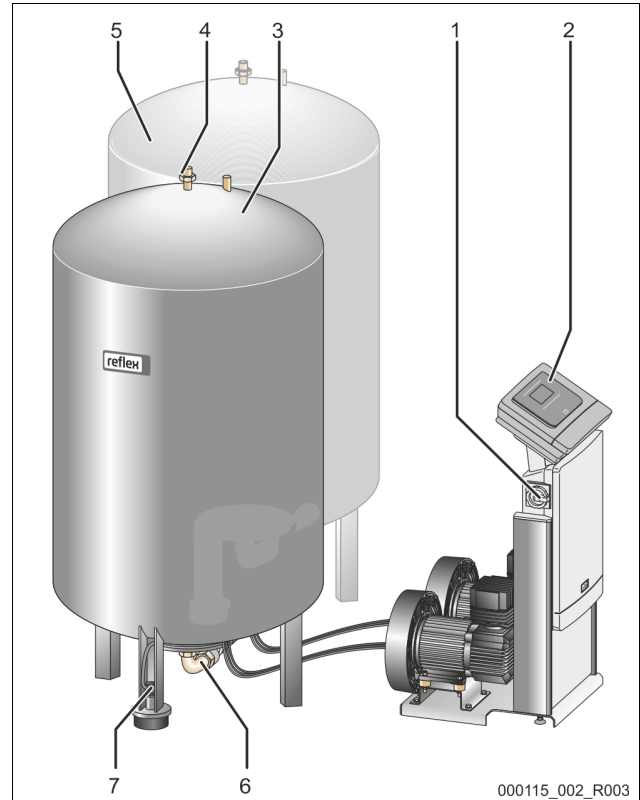

1	Main switch
2	Control unit
3	"RG" primary vessel
4	"SV" safety valve

5	"RF" secondary vessel (optional)
6	"EC" expansion line
7	"LIS" level sensor

4.3 Identification

4.3.1 Nameplate

The nameplate provides information about the manufacturer, the year of manufacture, the manufacturing number and the technical data.

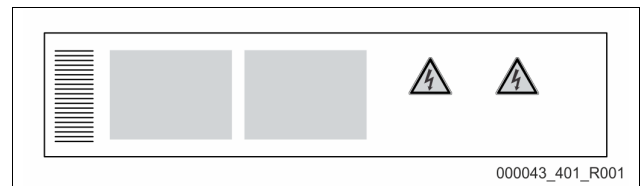

Information on the type plate	Meaning
Type	Device name
Serial No.	Serial number
min. / max. allowable pressure P	Minimum/maximum permissible pressure
max. continuous operating temperature	Maximum temperature for continuous operation
min. / max. allowable temperature / flow temperature TS	Minimum / maximum permissible temperature / TS flow temperature
Year built	Year of manufacture
min. operating pressure set up on shop floor	Factory set minimum operating pressure
at site	Set minimum operating pressure
max. pressure safety valve factory - aline	Factory set actuating pressure of the safety valve
at site	Set actuating pressure of the safety valve

4.3.2 Type code

No.		Reflexomat RS type key	
1	Control unit designation	Reflexomat RS 90 / 1, RG 1000 I, RF 1000 I	
2	Number of compressors		
3	"RG" primary vessel		1 2 3 4 5 6
4	Nominal volume		
5	"RF" secondary vessel		
6	Nominal volume		

4.4 Function

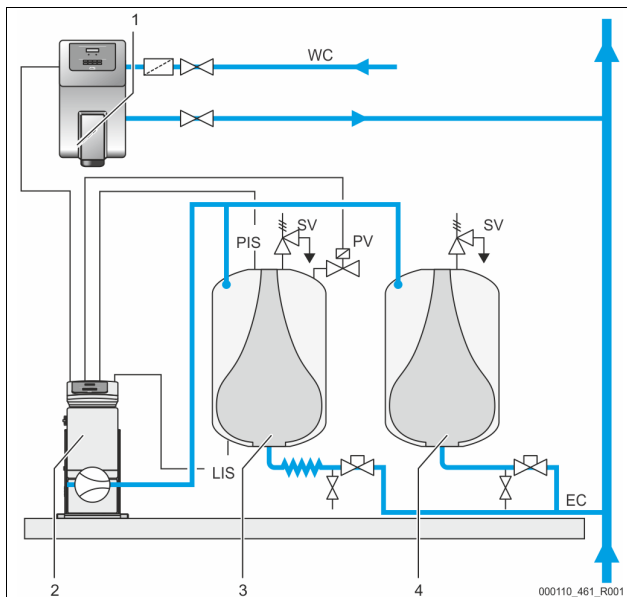

1	Make-up with water using "Fillcontrol Auto"
2	Control unit
3	Primary vessel as expansion vessel
4	Secondary vessel as additional expansion vessel
WC	Make-up pipe
PIS	Pressure sensor
SV	Safety valve
PV	Solenoid valve
LIS	Pressure load cell
EC	Expansion pipe

Expansion vessels

One primary vessel and multiple optional secondary vessels may be connected. A membrane separates the vessels into an air and a water space, preventing the penetration of atmospheric oxygen into the expansion water. The primary vessel is connected to the control unit downstream and connected hydraulically to the plant system. The pressure is protected at the air side by the "SV" safety valves of the vessels.

Control unit

The control unit contains one or optionally two compressors "CO" and the "Reflex Control Touch" controller. Via the primary vessel, the pressure is measured with the "PIS" pressure sensor and the water level with the "LIS" pressure load cell and the values then displayed in the controller display.

Pressurisation

- If the water is heated, it expands and the pressure increases in the plant system. If the pressure set at the controller is exceeded, the "PV" solenoid valve opens and discharges air from the primary vessel. Water flows from the system into the primary vessel and the pressure drops in the plant system until the pressure in the plant system and the primary vessel is equalised.
- The pressure in the plant system drops when the water cools. When the pressure drops below the set value, the "CO" compressor cuts in and delivers compressed air into the primary vessel. This displaces water out of the primary vessel into the plant system. The pressure in the facility system rises.

Make-up

The addition of more water is controlled within the controller. The "LIS" pressure load cell determines the water level and sends this value to the controller of the pressure maintaining station. This controls an external make-up. Water is directly added into the system in a controlled manner by monitoring the make-up time and the make-up cycles.

If the water level in the primary vessel falls below minimum, a fault message is output from the controller and shown in the display.

- **Note!**
Additional equipment for topping up water, see chapter 4.6 "Optional equipment and accessories" on page 5.

4.5 Scope of delivery

The scope of delivery is described in the shipping document and the content is shown on the packaging.

Immediately after receipt of the goods, please check the shipment for completeness and damage. Please notify us immediately of any transport damage.

Basic pressure-maintaining equipment:

- Control unit with one or two compressor(s) including compressed air line(s).
- Primary tank with flexible water connection.
- "LIS" pressure load cell for level sensing.

4.6 Optional equipment and accessories

- Secondary vessels with connection sets for the primary vessel.
- For make-up with water
 - Make-up without pump:
 - Solenoid "Fillvalve" with ball valve and Reflex Fillset for make-up with drinking water.
 - Make-up with pump:
 - Reflex Fillcontrol Auto, with integrated pump and a system separation vessel or Auto Compact
- For make-up and degassing with water:
 - Reflex Servitec S
 - Reflex Servitec 35- 95
- Fillset for make-up with drinking water.
 - With integrated system separator, water meter, dirt trap and locking mechanisms for the "WC" make-up line.
- Fillset Impulse with FQIRA+ contact water meter for make-up with drinking water.
- Fillsoft for softening or desalination of the make-up water from the drinking water network.
 - Fillsoft is installed between Fillset and the device. The device controller evaluates the make-up quantities and signals the required replacement of the softening cartridges.
- Optional expansions for Reflex controllers:
 - I/O module for standard communication, see chapter 5 "I/O module (optional expansion module)" on page 6.
 - Master-Slave-Connect for master controllers for maximum 10 devices.
 - Bus modules:
 - Profibus DP
 - Ethernet
- Diaphragm rupture monitor

- **Note!**
Separate operating instructions are supplied with accessories.

5 I/O module (optional expansion module)

The I/O module is connected and wired in the factory. It is used to expand the inputs and outputs Control Touch controller.

Six digital inputs and six digital outputs are used to process messages and alarms:

Inputs
Three inputs, N.C. with 24 V self potential for standard settings. <ul style="list-style-type: none"> External temperature monitoring Minimum pressure signal Manual make-up of water
Three inputs, N.O. with 230 V self potential for standard settings. <ul style="list-style-type: none"> Emergency-Off Manual operation (e.g. for pump or compressor) Manual operation for the overflow

Outputs
Potential-free as changeover contacts. Default settings for messages: <ul style="list-style-type: none"> Make-up fault Below minimum pressure Above maximum pressure Manual or Stop operation

- Note!**
- For the default settings of the I/O modules, see Chapter 5.2.3 "I/O module default settings" page 7
 - All digital inputs and outputs can be set freely as option. Settings to be made by Reflex Customer Service, see chapter 13.1 "Reflex Customer Service" on page 23

5.1 Technical data

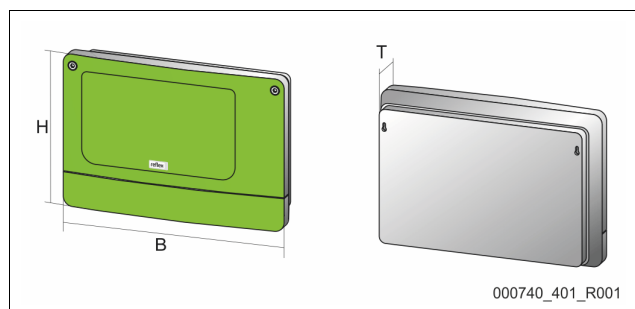

Housing	Plastic housing
Width (W):	340 mm
Height (H):	233.6 mm
Depth (D):	77 mm
Weight:	2.0 kg
Permissible operating temperature:	-5 °C – 55 °C
Permissible storage temperature:	-40 °C – 70 °C
Degree of protection IP:	IP 64
Power supply:	230 V AC, 50 – 60 Hz (IEC 38)
Fuse (primary):	0.16 A time-lag

Inputs, outputs
<ul style="list-style-type: none"> 6 floating relay outputs (changeover) 3 digital inputs 230 V AC 3 digital inputs 24 V AC 2 Analogue outputs (these are not required, because they are already contained in the Control Touch controller).

Interfaces to the controller
<ul style="list-style-type: none"> RS-485 19.2 kbit/s Floating connection with plug or screw terminals RSI-specific protocol

5.2 Settings



- Danger to life from electric shock!**
Risk of serious injury or death due to electric shock. Some parts of the main board may still carry 230 V voltage even with the device physically isolated from the 230 V power supply.
- Before you remove the covers, completely isolate the device controller from the power supply.
 - Verify that the main circuit board is voltage-free.

5.2.1 Terminator settings in RS-485 networks

Examples for the activation and deactivation of terminators in RS-485 networks.

- DIP switches 1 and 2 are located on the main board of the controller.
- Maximum length for an RS-485 connection is 1000 metres

Device controller with I/O module

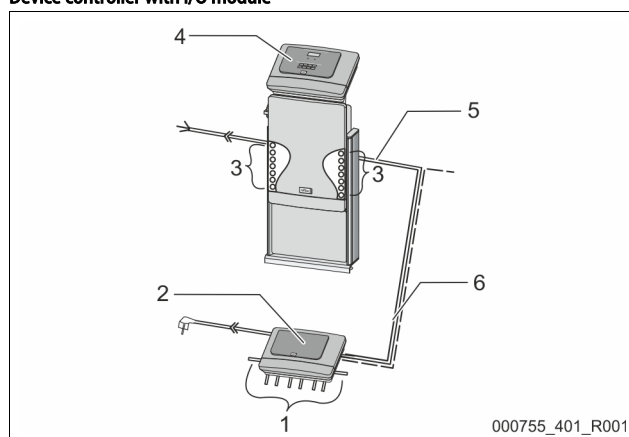

1	Relay outputs of the I/O module* <ul style="list-style-type: none"> 6 digital outputs 	4	"Control Touch" controller
2	I/O module	5	RS-485 connection
3	Connections of the I/O conductors	6	Optional RS-485 connection <ul style="list-style-type: none"> Master - Slave Field bus

* The 2 analogue outputs are not required because the Control Touch controller already has two analogue outputs for pressure and level measurement.

	Terminator settings		
Jumper/switch	Settings	I/O module	Control Touch
Jumper J10 and J11	Activated	X	---
	Deactivated	---	---
DIP switch 1 and 2	Activated	---	X
	Deactivated	---	---

Device controllers and I/O module in Master-Slave function

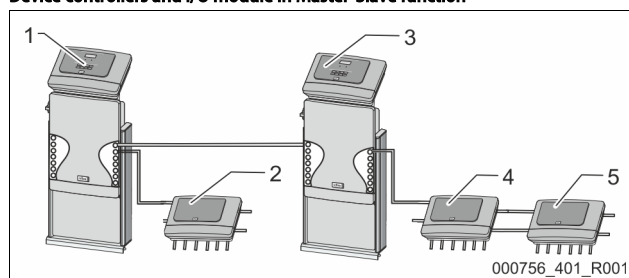

1	Control Touch controller in Master function	4	I/O module for the Slave function
2	I/O module for the Master function	5	I/O module for expansion
3	Control Touch controller in Slave function		

Master function

Jumper/switch	Terminator settings		
	Settings	I/O module	Control Touch
Jumper J10 and J11	Activated	X	---
	Deactivated	---	---
DIP switch 1 and 2	Activated	---	X
	Deactivated	---	---

Slave function

Jumper / Switch	Terminator settings			
	Settings	I/O module	I/O module for expansion	Control Touch
Jumper J10 and J11	Activated	---	X	---
	Deactivated	X	---	---
DIP switch 1 and 2	Activated	---	---	X
	Deactivated	---	---	---

5.2.2 Setting the module address

Setting of the module address on the I/O module's main circuit board

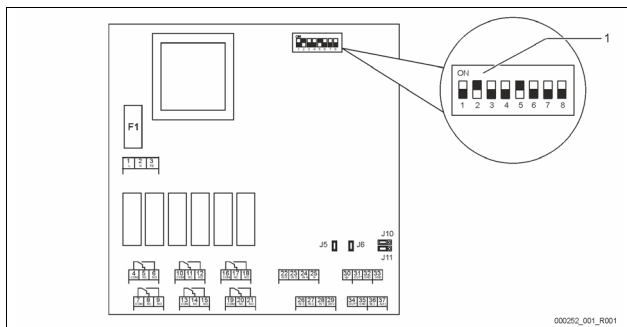

1	DIP switch
---	------------

DIP-switch position

- DIP switch 1 – 4:
- For setting the module address
 - Variable setting to ON or OFF
- DIP switch 5:
- Permanently to position ON
- DIP switch 6 – 8:
- For internal testing
 - To position OFF during operation

Use DIP switches 1 – 4 to set the module address.

Proceed as follows:

1. Pull out the mains plug of the I/O module.
2. Open the housing cover.
3. Set DIP switches 1 – 4 to position ON or OFF.

Module address	DIP switch								Used for the modules
	1	2	3	4	5	6	7	8	
1	1	0	0	0	1	0	0	0	1
2	0	1	0	0	1	0	0	0	2
3	1	1	0	0	1	0	0	0	3
4	0	0	1	0	1	0	0	0	4
5	1	0	1	0	1	0	0	0	5
6	0	1	1	0	1	0	0	0	6
7	1	1	1	0	1	0	0	0	7
8	0	0	0	1	1	0	0	0	8
9	1	0	0	1	1	0	0	0	9
10	0	1	0	1	1	0	0	0	10

5.2.3 I/O module default settings

The inputs and outputs of the I/O module each have default settings.

These default settings can be changed, if required, and adjusted to local conditions.

Responses by the inputs 1 – 6 of the I/O module are recorded and displayed in the device controller's fault memory.

Note!

- Default settings apply to software version V1.10 and higher.
- All digital inputs and outputs can be set freely as option. The setting is carried out by Reflex Customer Service, see chapter 13.1 "Reflex Customer Service" on page 23

Location	Signal evaluation	Message text	Fault memory entry	Priority	Signal on the input triggers the following action
INPUTS					
1	N.C.	External temperature monitoring	Yes	Yes	<ul style="list-style-type: none"> • Solenoid valves are closed. <ul style="list-style-type: none"> • Solenoid valve (2) in overflow line (1) • Solenoid valve (3) in overflow line (2) • Output relay (1) is switched.
2	N.C.	External signal, Minimum pressure	Yes	No	<ul style="list-style-type: none"> • Solenoid valves are closed. <ul style="list-style-type: none"> • Solenoid valve (2) in overflow line (1) • Solenoid valve (3) in overflow line (2) • Output relay (2) is switched.
3	N.C.	Manual make-up	Yes	Yes	<ul style="list-style-type: none"> • Solenoid valve (1) in make-up line is manually opened. • Output relay (5) is switched.
4	N.O.	Emergency-Off	Yes	Yes	<ul style="list-style-type: none"> • Pumps (1) and (2) are switched off. • Solenoid valves (2) and (3) in the overflow lines are closed. • Solenoid valve (1) in the make-up line is closed. • Switches "Group alarm" in the device controller.
5	N.O.	Manual pump 1	Yes	Yes	<ul style="list-style-type: none"> • Pump (1) is manually switched on. • Output relay (5) is switched.
6	N.O.	Manual OF-1	Yes	Yes	Solenoid valve (1) is opened.
OUTPUTS					
1	Changeover contact	---	---	---	See input 1
2	Changeover contact	---	---	---	See input 2
3	Changeover contact	---	---	---	<ul style="list-style-type: none"> • Below minimum pressure. • "ER 01" message in the controller

Location	Signal evaluation	Message text	Fault memory entry	Priority	Signal on the input triggers the following action
OUTPUTS					
4	Changeover contact	---	---	---	<ul style="list-style-type: none"> Maximum pressure exceeded "ER 10" message in the controller
5	Changeover contact	---	---	---	Switches in manual mode Switches in stop mode Switches with inputs 3,5,6 active
6	Changeover contact	Make-up fault	---	---	<ul style="list-style-type: none"> Make-up setting values exceeded. Switches the following messages in the device controller: <ul style="list-style-type: none"> "ER 06", Make-up time "ER 07", Make-up cycles "ER 11", Make-up quantity "ER 15", Make-up valve "ER 20", Maximum make-up quantity

5.3 Replacing the fuses



Risk of electric shock!
 Risk of serious injury or death due to electric shock. Some parts of the main board may still carry 230 V voltage even with the device physically isolated from the 230 V power supply.

- Before you remove the covers, completely isolate the device controller from the power supply.
- Verify that the main circuit board is voltage-free.

Fusing is provided on the I/O module's main circuit board.

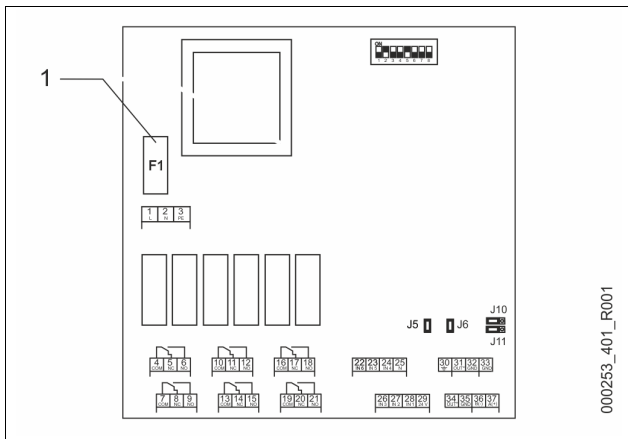

1 Microfuse F1 (250 V, 0, 16 A slow)

Proceed as follows:

- Disconnect the I/O module from the power supply.
 - Pull the power plug from the bus module.
- Open the terminal space cover.
- Remove the housing cover.
- Replace the defective fuse.
- Re-attach the housing cover.
- Close the terminal space cover.
- Reconnect the power supply for the module.

The fuse replacement is completed.

6 Technical data

6.1 Control unit

Note!

The following values apply for all control units:

- Permissible flow temperature: 120 °C
- Permissible operating temperature: 70 °C
- Permissible ambient temperature: 0 °C – 45 °C
- Permissible operating gauge pressure: 10 bar
- Dimensions (H x W x D) mm: 415 x 395 x 520
- Degree of protection: IP 54
- Number of RS-485 interfaces: 1
- I/O module: optional

Type	Electrical power [kW]	Power supply [V / Hz; A]	Control unit electrical voltage [V; A]	Sound level [dB]	Weight [kg]
RS 90/1 T	0.7	230 / 50; 3	230; 2	72	32
RS 90/2	1.5	230 / 50; 6,5	230; 2	72	45
RS 150/1	1.1	400 / 50; 5	230; 2	72	45
RS 150/2	2.2	400 / 50; 10	230; 2	72	60
RS 300/1	2.2	400 / 50; 10	230; 2	76	48
RS 300/2	4.4	400 / 50; 19	230; 2	76	86
RS 400/1	2.4	400 / 50; 10,5	230; 2	76	62
RS 400/2	4.8	400 / 50; 21	230; 2	76	118
RS 580/1	3.0	400 / 50; 13	230; 2	76	102
RS 580/2	6.0	400 / 50; 26	230; 2	76	196

6.2 Tanks

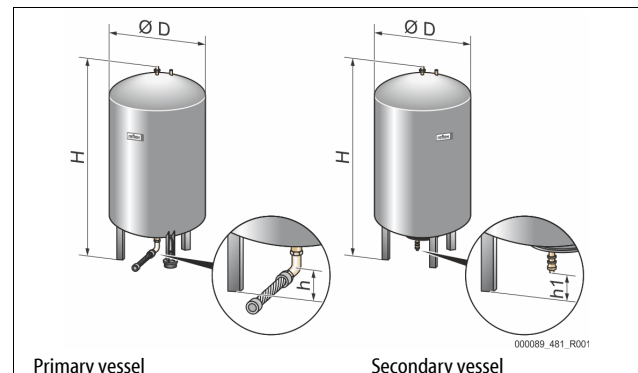

Type	Diameter Ø "D" (mm)	Weight (kg)	Connection (inches)	Height "H" (mm)	Height "h" (mm)	Height "h1" (mm)
6 bar - 200	634	37	R1	970	115	155
6 bar - 300	634	54	R1	1270	115	155
6 bar - 400	740	65	R1	1255	100	140
6 bar - 500	740	78	R1	1475	100	140
6 bar - 600	740	94	R1	1720	100	140
6 bar - 800	740	149	R1	2185	100	140
6 bar - 1000	1000	156	DN65	2025	195	305
6 bar - 1500	1200	465	DN65	2025	185	305
6 bar - 2000	1200	565	DN65	2480	185	305
6 bar - 3000	1500	795	DN65	2480	220	334
6 bar - 4000	1500	1080	DN65	3065	220	334
6 bar - 5000	1500	1115	DN65	3590	220	334
10 bar - 350	750	230	DN40	1340	190	190
10 bar - 500	750	275	DN40	1600	190	190
10 bar - 750	750	345	DN50	2185	180	180
10 bar - 1000	1000	580	DN65	2065	165	285
10 bar - 1500	1200	800	DN65	2055	165	285
10 bar - 2000	1200	960	DN65	2515	165	285
10 bar - 3000	1500	1425	DN65	2520	195	310
10 bar - 4000	1500	1950	DN65	3100	195	310
10 bar - 5000	1500	2035	DN65	3630	195	310

7 Installation

DANGER

Risk of serious injury or death due to electric shock.

If live parts are touched, there is risk of life-threatening injuries.

- Ensure that the system is voltage-free before installing the device.
- Ensure that the system is secured and cannot be reactivated by other persons.
- Ensure that installation work for the electric connection of the device is carried out by an electrician, and in compliance with electrical engineering regulations.

CAUTION

Risk of injury due to pressurised liquid

If installation, removal or maintenance work is not carried out correctly, there is a risk of burns and other injuries at the connection points, if pressurised hot water or hot steam suddenly escapes.

- Ensure proper installation, removal or maintenance work.
- Ensure that the system is de-pressurised before performing installation, removal or maintenance work at the connection points.

CAUTION

Risk of burns on hot surfaces

Hot surfaces in heating systems can cause burns to the skin.

- Wear protective gloves.
- Please place appropriate warning signs in the vicinity of the device.

CAUTION

Risk of injury due to falls or bumps

Bruising from falls or bumps on system components during installation.

- Wear personal protective equipment (helmet, protective clothing, gloves, safety boots).

WARNING

Risk of injury due to heavy weight

The devices are heavy. Consequently, there is a risk of physical injury and accidents.

- Use suitable lifting equipment for transportation and installation.

Note!

Confirm that installation and start-up have been carried out correctly using the installation and commissioning certificate. This action is a prerequisite for the making of warranty claims.

- Have the Reflex Customer Service carry out commissioning and the annual maintenance.

7.1 Installation conditions

7.1.1 Incoming inspection

Prior to shipping, this device was carefully inspected and packed. Damages during transport cannot be excluded.

Proceed as follows:

1. Upon receipt of the goods, check the shipment for
 - completeness and
 - possible transport damage.
2. Document any damage.
3. Contact the forwarding agent to register your complaint.

7.2 Preparatory work

Condition of the delivered device:

- Check all screw connections of the device for tight seating. Tighten the screws as necessary.

Preparing the device installation:

- No access by unauthorised personnel.
- Frost-free, well-ventilated room.
 - Room temperature 0 °C to 45 °C (32 °F to 113 °F).
- Level, stable flooring.
 - Ensure sufficient bearing strength of the flooring before filling the tanks.
 - Ensure that the control unit and the tanks are installed on the same level.
- Filling and dewatering option.
 - Provide a DN 15 filling connection according to DIN 1988 - 100 and En 1717.
 - Provide an optional cold water inlet.
 - Prepare a drain for the drain water.
- Electric connection, see chapter 6 "Technical data" on page 8 .
- Use only approved transport and lifting equipment.
 - The load fastening points at the tanks must be used only as installation resources.

7.3 Execution

ATTENTION

Damage due to improper installation

Additional device stresses may arise due to the connection of pipes or system equipment.

- Ensure that pipes are connected from the device to the system without them being stressed or strained.
- If necessary, provide support structures for the pipes or equipment.

For installation, proceed as follows:

- Position the device.
- Complete the primary tank and the optional secondary tanks.
- Create the water-side connections of the control unit to the system.
- Create the interfaces according to the terminal plan.
- Install the water connections between optional secondary tanks to each other and to the primary tank.



Notice!

For installation, note the operability of the valves and the inlet options of the connecting lines.

7.3.1 Positioning

Determine the device position.

- Control unit
- Primary vessel
- Optional secondary vessel

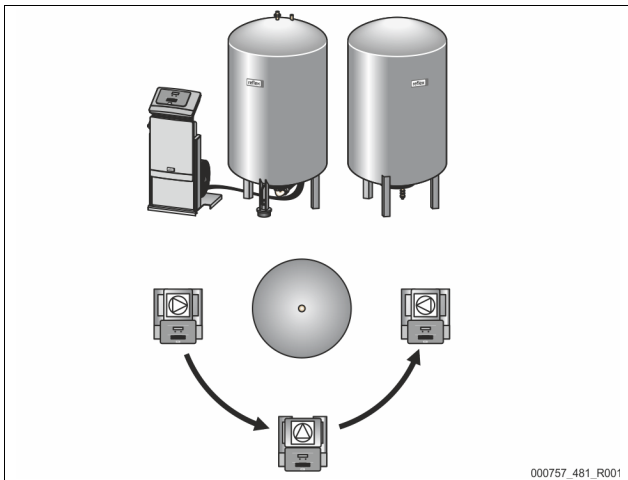

The control unit can be installed on either side or in front of the primary vessel. The distance of the control unit to the primary vessel results from the connection set supplied.

7.3.2 Tank installation

ATTENTION

Damage due to improper installation

Additional device stresses may arise due to the connection of pipes or system equipment.

- Ensure that pipes are connected from the device to the system without them being stressed or strained.
- If necessary, provide support structures for the pipes or equipment.

Comply with the following notes regarding the installation of the primary vessel and the secondary vessels:

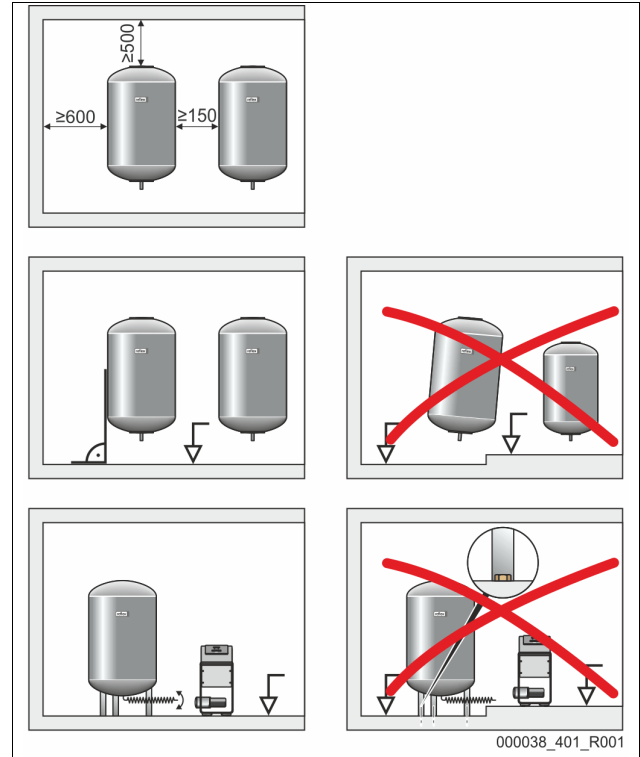

- All flange openings at the vessels are viewing and maintenance openings.
 - Place the vessels with sufficient distances to sides and ceiling.
- Install the vessels on a level surface.
- Ensure rectangular and free-standing position of the vessels.
- Use only vessels of the same type and dimensions when using secondary vessels.
- Ensure proper functioning of the "LIS" level sensor.
 - ATTENTION** Property damage caused by overpressure. Do not attach the vessels firmly to the floor.
- Install the control unit on the same level as the vessels.

7.3.3 Connection to the facility system

CAUTION

Risk of injury due to falls or stumbling

Bruising caused by falls or stumbling over cables or pipes during installation.

- Wear personal protective equipment (helmet, protective clothing, gloves, safety boots).
- Ensure proper installation of cables and pipes between the control unit and the vessels.

ATTENTION

Damage due to improper installation

Additional device stresses may arise due to the connection of pipes or system equipment.

- Ensure that pipes are connected from the device to the system without them being stressed or strained.
- If necessary, provide support structures for the pipes or equipment.

ATTENTION

Damage to cables and pipes

If cables and pipes are not routed professionally between tanks and the control unit, they may become damaged.

- Route cables and pipes in a professional manner over the flooring.

The following typical example describes the installation of the control unit upstream of the primary vessel and the connection of two secondary vessels. Proceed accordingly for other installation variants.

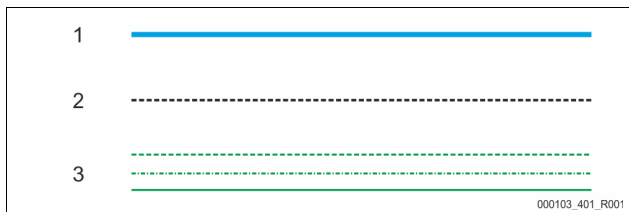
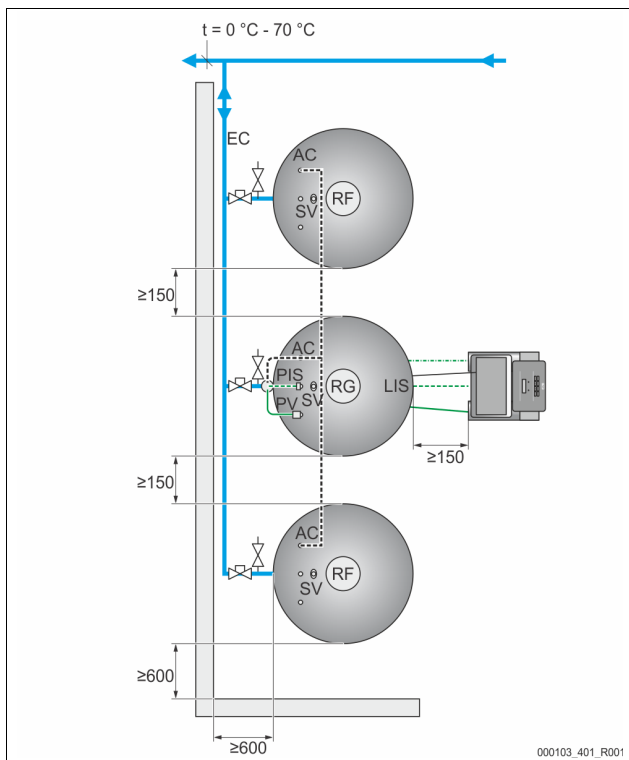

1	Expansion pipe	SV	Safety valve
2	Compressed air line	PV	Solenoid valve
3	Data line	PIS	Pressure sensor
RF	Secondary vessel	AC	Compressed air line
RG	Primary vessel	EC	Expansion pipe

7.3.3.1 Water-side connection

To ensure the proper function of the "LIS" level sensor, you must use the supplied hose to flexibly connect the primary vessel to the system. The "EC" expansion line provides secure locking and emptying for primary vessel and the optional secondary vessels. If more than one vessel is used, a collective line to the system is installed. Use points with temperatures between 0 °C and 70 °C to connect to the system. This is the return of the generator in heating systems and the flow in refrigeration systems. At temperatures below or above 0 °C – 70 °C, you must install in-line vessels between the system and the Reflexomat.

Note! For details regarding the switching of Reflexomats or in-line vessels and the dimensions of the expansion lines, please see the planning documents. More information is also provided in the Reflex Planning Guide.

7.3.3.2 Control unit connection

- The "PV" solenoid valve, the "PIS" pressure transducer and the corresponding cables are factory-installed on the primary vessel.
 - Run the cable through the assembly pipe on the rear of the primary vessel to the control unit.

- Subsequently install the level sensor at the primary vessel, see chapter 7.3.5 "Fitting the level sensor" on page 12.
 - Attach the cable to the "LIS" pressure pick-up of the level sensor and run the cable to the control unit.
- The flexible compressed air hose is connected with the control unit. Run the compressed air hose through the assembly pipe as well.
 - Control unit with one compressor:
 - Connect the compressed air line directly to the "AC" compressed air connection of the primary vessel.
 - Control unit with two compressors or additional secondary vessel:
 - First install the supplied distributor at the "AC" compressed air connection of the primary vessel.
 - Connect the compressed air lines of the compressors via the distributor.
 - Use the supplied connection sets to connect the secondary vessels.

7.3.4 Connection to an external compressed air line

An external pressure supply can optionally be connected to the Reflexomat. When doing so it must be ensured that a pressure reducer is fitted in the external pressure line. The minimum pressure to be set depends on the relevant pressure rating of the vessel.

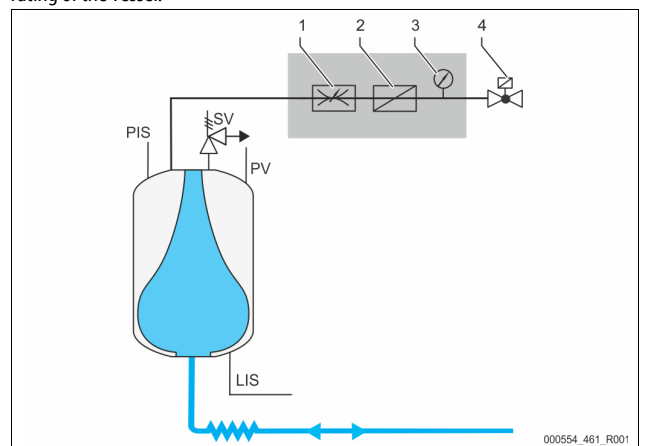

1	Pressure reducer, site attachment	PIS	Pressure sensor
2	Dirt trap, site attachment	SV	Safety valve
3	Pressure gauge, site attachment	PV	Overflow solenoid valve
4	Solenoid valve, supplied by Reflex	LIS	Level sensor

Instead of the compressor, a solenoid valve is actuated in the external compressed air line, which releases the compressed air for the vessel. The solenoid valve is activated by the controller. The electrical connection of the solenoid valve is made via the terminal for the compressor in the respective controller.

Properties of the external compressed air:

- Quality
 - Fluid group 2 according to the Pressure Equipment Directive 2014 / 68 EU.
 - DIN ISO 8573-1 Class 1.
- Oil-free
 - ATTENTION** Diaphragm damage caused by oil-containing compressed air. Keep the compressed air free of oil.
- Compressed air
 - ATTENTION** Damage to the vessel. The compressed air must be reduced to the respective vessel pressure rating.

Note! See chapter "Terminal plan" for the solenoid valve electrical connection.

7.3.5 Fitting the level sensor

ATTENTION

Damage to the pressure load cell due to unprofessional installation

Incorrect installation may result in damage to the "LIS" level sensor, malfunctioning and incorrect measurements from the pressure load cell.

- Comply with the instructions regarding the installation of the pressure load cell.

The "LIS" level sensor uses a pressure load cell. This pressure pick-up is to be installed after the primary vessel has been placed at its final position, see chapter 7.3.2 "Tank installation" on page 10. Comply with the following instructions:

- Remove the transport securing device (squared timber) at the vessel base of the primary vessel.
- Replace this transport securing device with the pressure load cell.
 - In the case of a vessel volume of 1000 l (Ø 1000 mm) or more, use the supplied screws to attach the pressure load cell at the vessel base of the primary vessel.
- Avoid shock-type loading of the pressure load cell by, for example, subsequent alignment of the vessel.
- Use flexible hoses to connect the primary vessel and the first secondary vessel.
 - Use only the supplied connection sets, see chapter 7.3.2 "Tank installation" on page 10.
- Perform a null balancing of the filling level when the primary vessel is aligned and fully emptied, see chapter 10.3 "Configuring settings in the controller" on page 18.

Standard values for level measurements:

Primary vessel	Measuring range
200 l	0 – 4 bar
300 – 500 l	0 – 10 bar
600 – 1000 l	0 – 25 bar
1500 – 2000 l	0 – 60 bar
3000 – 5000 l	0 – 100 bar

7.4 Make-up and degassing variants

7.4.1 Function

The filling level is recorded in the primary tank by the "LIS" level sensor and evaluated in the controller. When the water level falls below the value specified in the controller's customer menu, the external make-up is activated.

7.4.1.1 Make-up without pump

Reflexomat RS Touch with solenoid valve and ball valve.

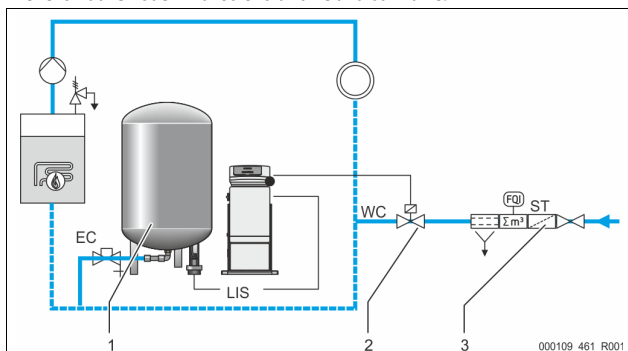

1		WC	Make-up pipe
2	Solenoid valve "Fillvalve" with ball valve	LIS	Level sensor
3	Reflex Fillset	EC	Expansion pipe
ST	Dirt trap		

Preferably, you should use the Reflex Fillset with integrated system separator when using drinking water for make-up. If you don't use a Reflex Fillset, you must use an "ST" dirt trap with a mesh size ≥ 0.25 mm for the make-up.

7.4.1.2 Make-up with pump

Reflexomat RS Touch with Reflex Fillcontrol Auto

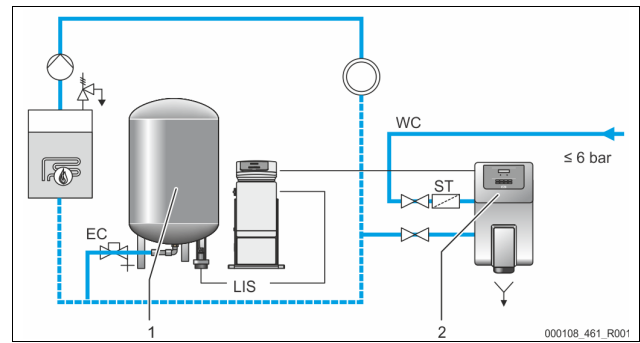

1		ST	Dirt trap
2	Fillcontrol Auto	EC	Expansion pipe
WC	Make-up pipe	LI	Level sensor
		S	

Water make-up with Fillcontrol Auto is suitable for make-up at high system pressures of up to 8.5 bar. The "ST" dirt trap is part of the deliverables.

7.4.1.3 Make-up with softening and degassing

Reflexomat RS Touch and Reflex Servitec.

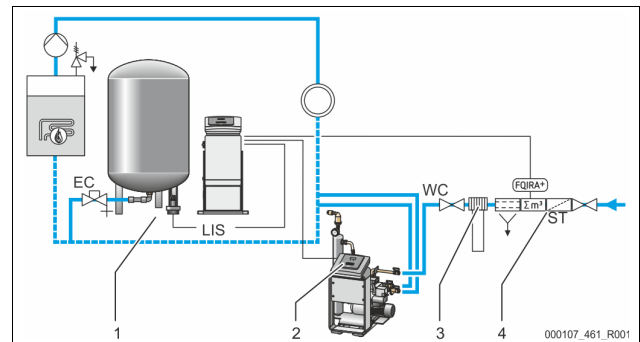

1		ST	Dirt trap
2	Reflex Servitec	WC	Make-up pipe
3	Reflex Fillsoft	LIS	Level sensor
4	Reflex Fillset Impulse	EC	Expansion pipe

The Reflex Servitec degassing and make-up station degasses the water from the facility system and the make-up water. The automatic water make-up for the facility system is controlled by the pressurisation system. Reflex Fillsoft additionally softens the make-up water.

- Reflex Servitec degassing and make-up station, see chapter 4.6 "Optional equipment and accessories" on page 5.
- Reflex Fillsoft softening systems and Reflex Fillset Impulse, see chapter 4.6 "Optional equipment and accessories" on page 5.

Note!

When using Reflex Fillsoft softening systems, always install the Reflex Fillset Impulse.

- The controller evaluates the make-up quantities and signals a required replacement of the softening cartridges.

7.5 Electrical connection



Risk of serious injury or death due to electric shock.

If live parts are touched, there is risk of life-threatening injuries.

- Ensure that the system is voltage-free before installing the device.
- Ensure that the system is secured and cannot be reactivated by other persons.
- Ensure that installation work for the electric connection of the device is carried out by an electrician, and in compliance with electrical engineering regulations.

For the electrical connection, you must differentiate between a connection component and an operating component.

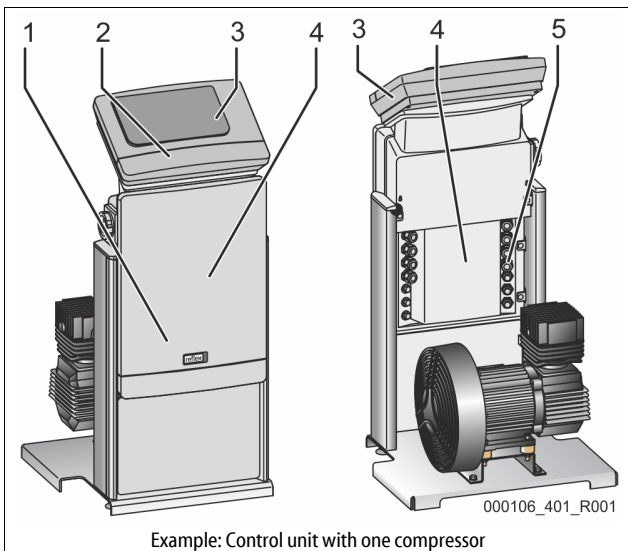

Example: Control unit with one compressor

1	Connection component cover (hinged)
2	Operating unit cover (hinged) • RS-485 interfaces • Pressure and Level outputs
3	Touch control
4	Connection component rear
5	Cable bushings • Supply and fusing • Floating contacts • "CO" compressor connection

The following descriptions apply to standard systems and are limited to the necessary user-provided connections.

1. Disconnect the system from the power source and secure it against unintentional reactivation.
2. Remove the covers.
DANGER Risk of serious injury or death due to electric shock. Some parts of the device's circuit board may still be live with 230 V even after the device has been physically isolated from the power supply by pulling out of the mains plug. Before you remove the covers, completely isolate the device controller from the power supply. Verify that the main circuit board is voltage-free.
3. Insert a suitable screwed cable gland for the cable bushing at the rear of the connection component. M16 or M20, for example.
4. Thread all cables to be connected through the cable glands.
5. Connect all cables as shown in the terminal diagrams.
 - Connection unit, see chapter 7.5.1 "Terminal plan, connection component" on page 13 .
 - Operating unit, see chapter 7.5.2 "Terminal plan, operating unit" on page 14 .
 - For installer supplied fusing, comply with the connected loads of the device , see chapter 6 "Technical data" on page 8 .

7.5.1 Terminal plan, connection component

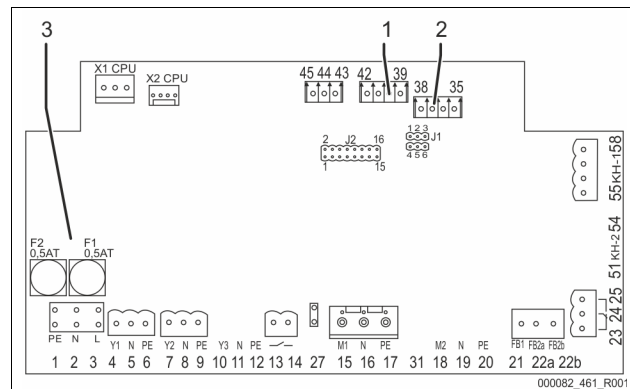

1	Pressure	3	Fuses
2	Level		

Terminal number	Signal	Function	Wiring
Supply			
X0/1	L	230 V supply Reflexomat RS 90	User supplied
X0/2	N		
X0/3	PE		
X0/1	L1	400 V supply Reflexomat RS 150 ... 580	User supplied
X0/2	L2		
X0/3	L3		
X0/4	N		
X0/5	PE		
Circuit board			
4	Y1	WV make-up valve	User, optional
5	N		
6	PE		
7	Y2	PV 1 solenoid valve	User supplied
8	N		
9	PE		
13		Dry-run protection message (floating)	User, optional
14			
23	NC	Group message (floating)	User, optional
24	COM		
25	NO		
35	+18 V (blue)	Analogue input, LIS level measuring at the primary vessel	User supplied
36	GND		
37	AE (brown)		
38	PE (shield)	PIS pressure sensor analogue input at the primary vessel	User, optional
39	+18 V (blue)		
40	GND		
41	AE (brown)	Digital inputs	User, optional
42	PE (shield)		
43	+24 V		
44	E1	E1: Contact water meter	Factory-provided
1	PE	Voltage supply	Not assigned
2	N		
3	L		

Terminal number	Signal	Function	Wiring
10	Y3	PV 2 solenoid valve	Factory-provided
11	N		
12	PE		
15	M1	Compressor 1 with 230 V systems, with 400 V systems via 6K1 motor protection	Factory-provided
16	N		
17	PE		
18	M2	Compressor 2 with 230 V systems, with 400 V systems via 6K1 motor protection	Factory-provided
19	N		
20	PE		
21	FB1	Compressor 1 voltage monitoring	Factory-provided
22a	FB2a	Compressor 2 voltage monitoring	Factory-provided
22b	FB2b	External make-up request together with 22a	---
27	M1	Flat plug for supply, compressor 1	Factory-provided
31	M2	Flat plug for supply, compressor 2	Factory-provided
45	E2	E2: Insufficient water switch	Factory-provided
51	GND	Solenoid valve 2	---
52	+24 V (supply)		
53	0 – 10 V (correcting variable)		
54	0 – 10 V (feedback)		
55	GND	Solenoid valve 1	---
56	+24 V (supply)		
57	0 – 10 V (correcting variable)		
58	0 – 10 V (feedback)		

7.5.2 Terminal plan, operating unit

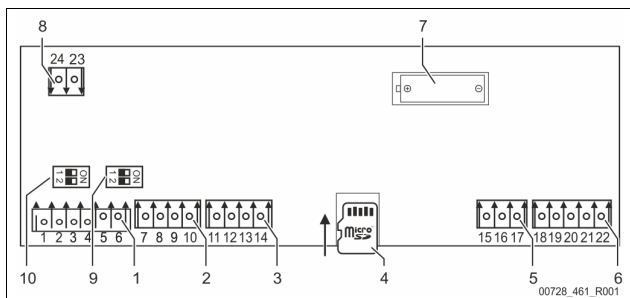

1	RS-485 interfaces
2	I/O interface
3	I/O interface (reserve)
4	Micro-SD card
5	10 V supply
6	Analogue outputs for Pressure and Level
7	Battery compartment
8	Bus module supply voltage
9	DIP switch 2
10	DIP switch 1

Terminal number	Signal	Function	Wiring
1	A	RS-485 interface S1 networking	User supplied
2	B		
3	GND S1		
4	A	RS-485 interface S2 modules: Expansion or communication module	User supplied
5	B		
6	GND S2		
7	+5 V	I/O interface: Interface to the main board	Factory
8	R × D		
9	T × D		
10	GND IO1	I/O interface: Interface to the main board (reserve)	---
11	+5 V		
12	R × D		
13	T × D	10 V supply	Factory
14	GND IO2		
15	10 V~		
16	FE	Analogue outputs: Pressure and Level Standard 4 – 20 mA	User supplied
17	Y2PE (shielding)		
18	Pressure		
19	GND A		
20	Level		
21	GND A		
22	GND A		

7.5.3 RS-485 interface

Use the S1 and S2 RS-485 interfaces to retrieve all controller data and to enable the communication with control centres or other devices.

- S1 interface
 - A maximum 10 devices can be used in a master-slave linked circuit via the this interface.
- S2 interface
 - "PIS" pressure and "LIS" level.
 - "CO" compressor operating states.
 - Operating states of the "PV" solenoid valve in the overflow line.
 - Operating states of the "WV" solenoid valve in the make-up line.
 - Aggregate volume of the FQIRA + contact water meter.
 - All messages, see chapter 10.3.3 "Messages" on page 19 .
 - All entries in the fault memory.

The following bus modules form part of the optional accessories available for interface communication.

- ▶ **Note!**
If required, please contact the Reflex Customer Service for the protocol of the RS-485 interface, details of the connections and information about the accessories offered.

7.5.3.1 Connecting the RS-485 interface

- Use a shielded cable to connect the interface to terminals 1 – 6 of the main board in the control cabinet.
 - For connecting the interface, see chapter 7.5 "Electrical connection" on page 13 .
- When using the device with a control centre not supporting an RS-485 interface (RS-232, for example), you must use a corresponding adapter.

- ▶ **Note!**
 - For connecting the interface use only a cable with these properties.
 - LJYCY (TP), 4 × 2 × 0.8, maximum overall bus length 1000 m.

7.6 Installation and commissioning certificate

- Note!**
The installation and commissioning certificate can be found at the end of the operating manual.

8 Commissioning

- Note!**
Confirm that installation and start-up have been carried out correctly using the installation and commissioning certificate. This action is a prerequisite for the making of warranty claims.
 - Have the Reflex Customer Service carry out commissioning and the annual maintenance.

8.1 Checking the requirements for commissioning

The device is ready for commissioning when the tasks described in Chapter Installation have been concluded. Comply with the following instructions for commissioning:

- The control unit is connected to the primary tank and the secondary tanks, if provided.
- The water connections of the tanks to the facility system are established.
- The tanks are not filled with water.
- The valves for emptying the tanks are open.
- The facility system is filled with water and gas-vented.
- The electrical connection has been created according to applicable national and local regulations.

8.2 Reflexomat switching points

The "P₀" minimum operating pressure is determined by the location of the pressurisation. The controller calculates the switching points for the "PV" solenoid valve and the "CO" compressor from the "P₀" minimum operating pressure.

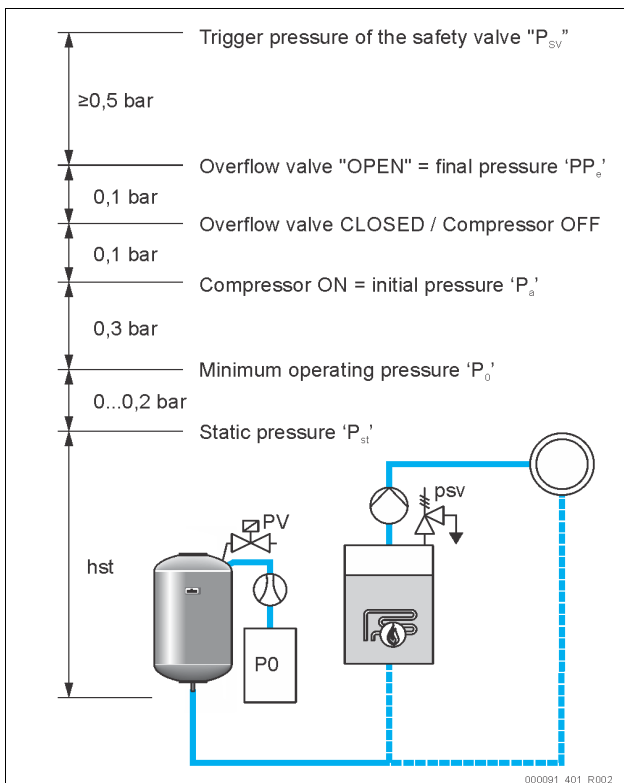

The "P₀" minimum operating pressure is calculated as follows:

$P_0 = P_{st} + P_D + 0.2 \text{ bar}^*$	Enter the calculated value in the start routine of the controller, see chapter 8.3 "Modifying the controller's start routine" on page 15 .
$P_{st} = h_{st}/10$	h_{st} in metres
$P_D = 0.0 \text{ bar}$	for safety temperatures $\leq 100 \text{ }^\circ\text{C}$
$P_D = 0.5 \text{ bar}$	for safety temperatures = $110 \text{ }^\circ\text{C}$

*Addition of 0.2 bar recommended, no addition in extreme cases

- Note!**
Avoid dropping below the "P₀" minimum operating pressure. Vacuum, vaporisation and cavitation are thus excluded.

8.3 Modifying the controller's start routine

- Note!**
During commissioning, you must once execute the start routine.
 - For information about controller operation, see chapter 10.1 "Operator panel" on page 17 .

The start routine is used to set the required settings for the device initial commissioning. It commences with the first activation of the controller and can be run only once. The settings can be changed or checked in the Customer menu after the start routine has terminated see chapter 13.1 "Reflex Customer Service" on page 23 .

A three-digit PM code is assigned to the setting options.

Step	PM Code	Description
1		Start of the start routine
2	001	Select the language
3		Remember: Prior to installation and commissioning, read the operating manual!
4	005	Set the minimum operating pressure "P ₀ ", see chapter 8.2 "Reflexomat switching points" on page 15 .
5	002	Set the time
6	003	Set the date
7	121	Select the primary vessel nominal volume
8		Null balancing: The primary vessel must be completely empty. The system checks whether the signal from the level sensor matches the selected primary vessel
		End of the start routine. The stop mode is active.

- Note!**
Provide the power supply (230 V) for the controller by pressing the main switch at the control unit.

The system automatically displays the first page of the start routine when you switch on the device for the first time.

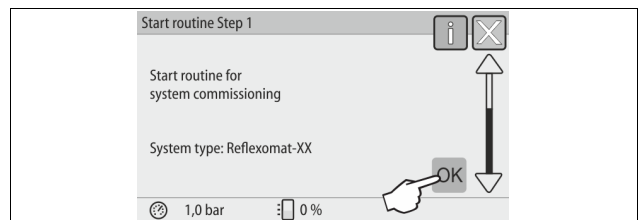

- Press "OK".
 - The start routine moves to the next page.

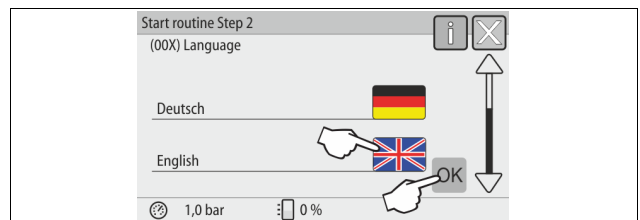

- Select the required language and conform your entry with "OK".

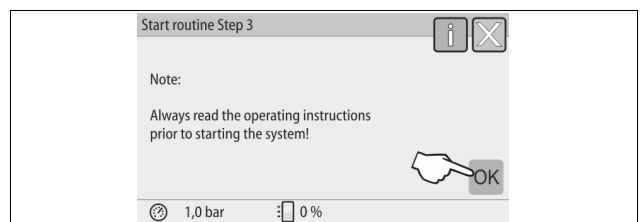

- Follow the instruction and confirm with the "OK" button.

Note!
Always read the operating instructions prior to starting the system!

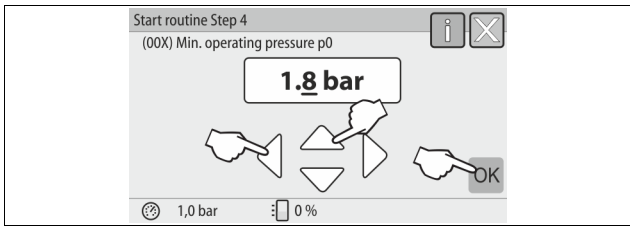

4. Select the calculated minimum operating pressure and conform your entry with "OK".
 - For calculation of the minimum operating pressure, see chapter 8.2 "Reflexomat switching points" on page 15 .

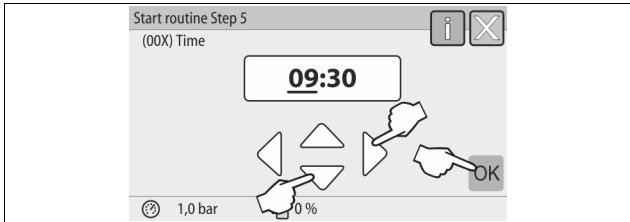

5. Set the time.
 - Use the "Left" and "Right" buttons to select the display value.
 - Use the "Up" and "Down" buttons to change the display value.
 - Confirm your entries with "OK".
 - The time of an alarm will be stored in the fault memory of the controller.

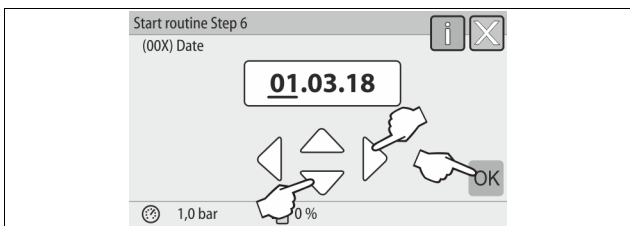

6. Set the date.
 - Use the "Left" and "Right" buttons to select the display value.
 - Use the "Up" and "Down" buttons to change the display value.
 - Confirm your entries with "OK".
 - The date of an alarm will be stored in the fault memory of the controller.

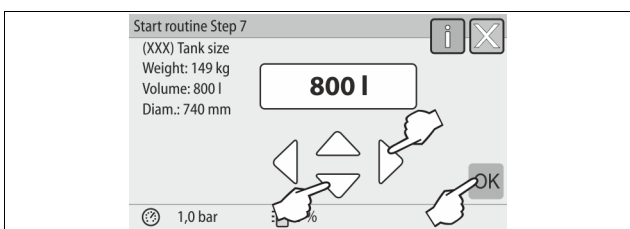

7. Select the size of the primary vessel.
 - Use the "Up" and "Down" buttons to change the display value.
 - Confirm your entries with "OK".
 - For the primary vessel data, see the name plate or see chapter 6 "Technical data" on page 8 .

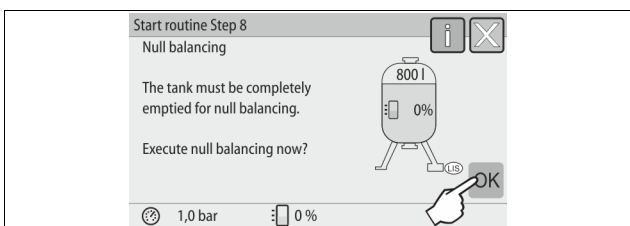

- The controller checks whether the level measuring signal matches the dimensional data of the primary vessel. The primary vessel must be fully emptied, see chapter 7.3.5 "Fitting the level sensor" on page 12 .

8. Press "OK".
 - Null balancing is executed.
 - If null balancing is not successfully completed, you cannot commission the device. In this case, please contact Customer Service, see chapter 13.1 "Reflex Customer Service" on page 23 .

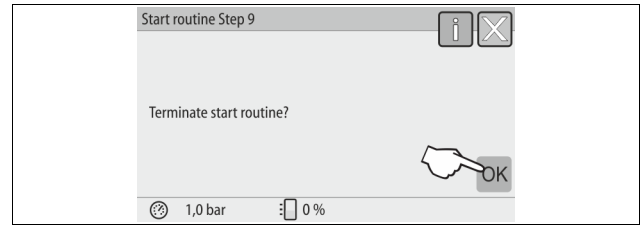

9. Once null balancing has concluded successfully, you can end the start routine by pressing the "OK" button.

Note!
After successful conclusion of the start routine, you are in Stop mode. Do not yet switch to Automatic mode.

8.4 Venting the vessels

CAUTION

Risk of burns on hot surfaces

- Excessive surface temperatures on the compressor can result in skin burns.
- Wear suitable personal protective equipment (safety gloves, for example).

Upon completion of the start routine, you must vent the primary vessel and the secondary vessels, if applicable.

- Open the vessels' discharge ports to permit the air to escape.
- Select Automatic mode on the controller's operator panel, see chapter 9.1.1 "Automatic mode" on page 17 .

The "CO" compressor builds up the pressure required venting. This pressure is 0.4 bar above the set minimum operating pressure. The vessels' diaphragms are pressurised to this level and the water side in the vessels is vented. Close the discharge ports of all vessels after the compressor has automatically shut down.

Note!
Inspect all compressed air connections between the control unit and the vessels for leaks. Subsequently, slowly open all cap valves at the vessels to create the water-side connection to the facility system.

8.5 Filling the tanks with water

Prerequisite for fault-free filling is a make-up pressure at least 1.3 bar above the set minimum pressure "P₀".

- Without automatic make-up:
 - Use the discharge ports or the facility system to manually fill the individual tank to approximately 30 % of the tank volume, see chapter 7.4 "Make-up and degassing variants" on page 12 .
- With automatic make-up:
 - The tanks are automatically filled to approximately 12 % of the tank volume, see chapter 7.4 "Make-up and degassing variants" on page 12 .

8.6 Starting Automatic mode

Automatic operation is executed as conclusion of the initial commissioning. The following prerequisites must be met for automatic operation:

- The device is filled with compressed air and water.
- All required settings are defined in the controller.

Start the automatic mode at the operator panel of the controller.

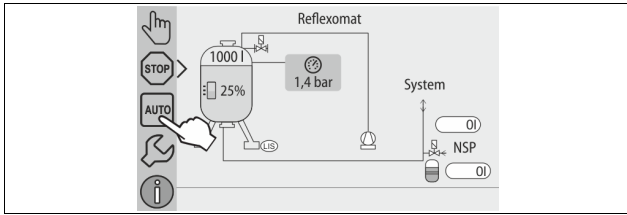

1. Press "AUTO".
 - The "CO1" compressor is switched on.

Note!
The commissioning process is now concluded.

9 Operation

9.1 Operating modes

9.1.1 Automatic mode

Use:
After initial commissioning has been successfully completed

Start:
Press "AUTO".

Functions:

- Automatic mode is suitable for continuous device operation and the controller monitors the following functions:
 - Pressurisation
 - Expansion volume compensation
 - Automatic make-up.
- The "CO" compressor and the "PV1" solenoid valve are regulated by the controller so that the pressure remains constant in a regulation range of ± 0.1 bar.
- Faults are indicated and evaluated in the display.

9.1.2 Manual mode

Use:
For testing and maintenance tasks.

Start:

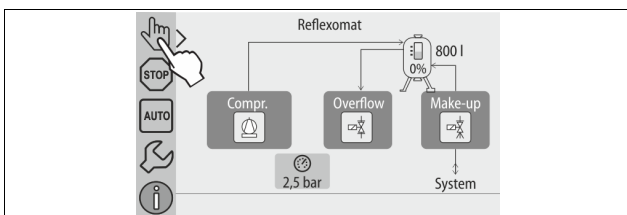

1. Press "Manual mode".
2. Select the desired function.

Functions:

Manual mode allows you to select the following functions and to perform a test run:

- "CO1" compressor.
- Solenoid valve in "PV1" overflow line.
- Solenoid valve "WV1" for make-up.

You have the option to simultaneously switch multiple functions and to test them in parallel. Switch the function on and off by touching the corresponding button:

- The button is highlighted green. The function is switched off.

Press the desired button:

- The button is highlighted blue. The function is switched on.

The change in the filling level and the vessel pressure are indicated on the display.

Note!
Manual operations cannot be performed if safety-relevant parameters would be exceeded. Switching is then disabled.

9.1.3 Stop mode

Use:
For device commissioning.

Start:

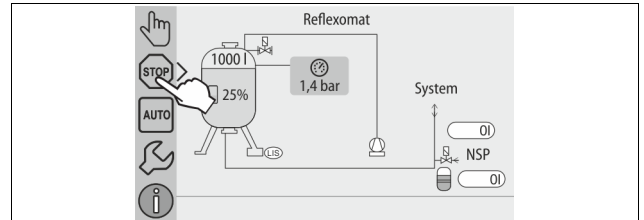

Press "STOP".

Functions:

Except for the display of information, the device is non-functional in Stop mode. Function monitoring is stopped.

The following functions are deactivated:

- The "CO" compressor is switched off.
- The solenoid valve in the "PV" overflow line is closed.
- The solenoid valve in the "WV" make-up line is closed.

Note!
The system returns an alarm if the Stop mode is activated for more than 4 hours.
If "Floating alarm contact?" in the Customer menu is set to "Yes", the system outputs the alarm to the group alarm contact.

10 Controller

10.1 Operator panel

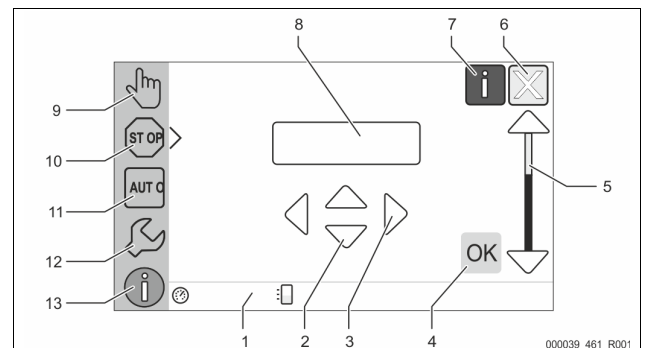

1	Message line	8	Display value
2	"▼"/"▲" buttons • Set digits.	9	"Manual mode" button • For function tests.
3	"◀"/"▶" buttons • Select digits.	10	"Stop mode" button • For commissioning.
4	"OK" button • Confirm/acknowledge input. • Browse in the menu.	11	"Automatic mode" button • For continuous operation.
5	"Up" and "Down" scroll bar • "Scroll" in the menu.	12	"Set-up menu" button • For setting parameters. • Fault memory. • Parameter memory. • Display settings. • Primary vessel information. • Software version information.
6	"Scroll back" button • Cancel. • Page back to the main menu.	13	"Info menu" button • Displays general information.
7	"Display help texts" button • Opens help texts.		

10.2 Calibrating the touch screen

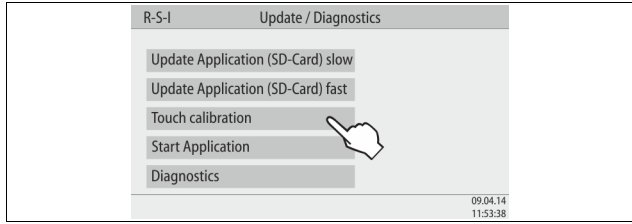

You can calibrate the touch screen when touching the desired buttons does not work satisfactorily.

1. Switch the device off at the main switch.
2. Touch and hold the touch field with your finger.
3. Switch on the main switch while touching the touch field.
 - When starting the program, the controller automatically switches to the "Update/Diagnostics" function.
4. Touch the "Touch calibration" button.

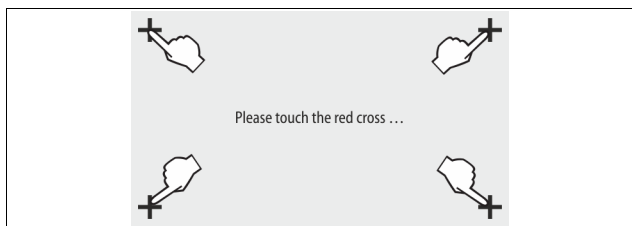

5. Touch the displayed crosses on the touch screen after each other.
6. Switch the device off and on again at the main switch.

The touch screen is fully calibrated.

10.3 Configuring settings in the controller

You can configure the controller settings regardless of the currently selected and active operating mode.

10.3.1.1 Customer menu – overview

Use the Customer menu to correct or determine system-specific values. In the course of initial commissioning, the factory settings must be adjusted for the system-specific conditions.

Note!
 For a description of the operation, see chapter 10.1 "Operator panel" on page 17.

A three-digit PM code is assigned to the setting options

PM Code	Description
001	Select the language
002	Set the time
003	Set the date
	Execute null balancing <ul style="list-style-type: none"> - The primary vessel must be empty! - The system checks whether the signal from the level sensor matches the selected primary vessel.
005	Set the minimum operating pressure P_0 , see chapter 8.2 "Reflexomat switching points" on page 15.
	Make-up > <ul style="list-style-type: none"> 021 • Make-up ON at ...% 022 • Make-up OFF at ...% 023 • Maximum make-up time ...min 024 • Maximum make-up cycles ... /2 h 027 • With contact water meter "Yes/No" <ul style="list-style-type: none"> - If "Yes", continue with 028 028 • Reset make-up volume "Yes/No". 029 • Maximum make-up volume ... l

PM Code	Description
030	<ul style="list-style-type: none"> • With softening "Yes/No" <ul style="list-style-type: none"> - If "Yes", continue with 031
031	<ul style="list-style-type: none"> • Shut off make-up "Yes/No" (if water capacity is exhausted)
033	<ul style="list-style-type: none"> • Hardness reduction ... °dH = GHactual – GHtarget
032	<ul style="list-style-type: none"> • Soft water capacity <ul style="list-style-type: none"> - Fillsoft I: Soft water capacity = 6000 l / hardness reduction - Fillsoft II: Soft water capacity = 12000 l / hardness reduction
034	<ul style="list-style-type: none"> • replacement interval... months (for softening cartridges according to manufacturer).
007	Maintenance interval... months
008	Floating contact <ul style="list-style-type: none"> • Message selection > <ul style="list-style-type: none"> - Message selection: only messages marked with "√" are output. - All messages: All messages are output.
	Fault memory > History of all messages
	Parameter memory > History of parameter input
	Display settings > Brightness, screen saver
009	<ul style="list-style-type: none"> • Brightness ... %
010	<ul style="list-style-type: none"> • Screen saver brightness ... %
011	<ul style="list-style-type: none"> • Screen saver delay ...min
	Information > <ul style="list-style-type: none"> • Vessel: Vessel information • Software version

10.3.1.2 Setting the customer menu - "Time" example

The setting of system-specific values is explained below using the setting of the time as example.

To adjust the system-specific values, proceed as follows:

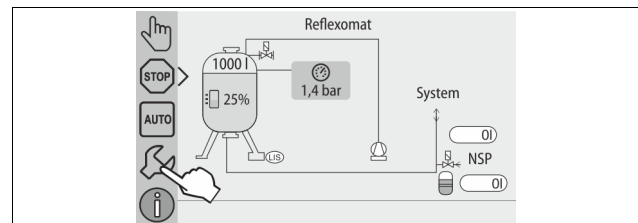

1. Press "Settings".
 - The controller switches to the setting area.

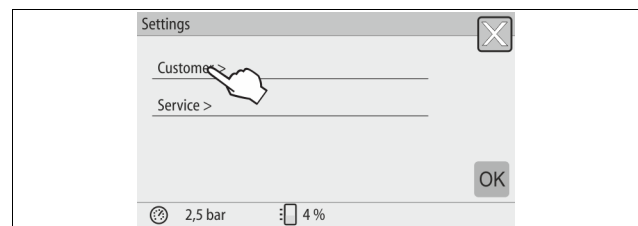

2. Press "Customer >".
 - The controller opens the Customer menu.

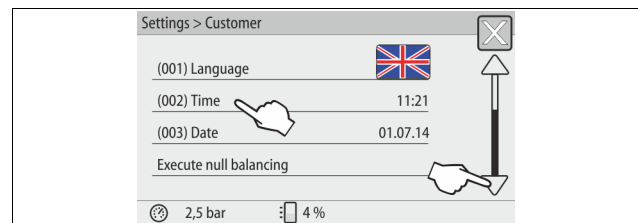

3. Press the required area.
 - The controller switches to the selected area.
 - Use the scroll bar to navigate through the list.

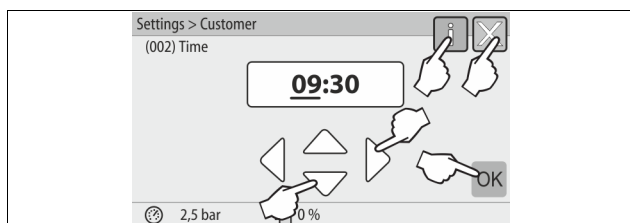

4. Set the system-specific values for the individual areas.
 - Use the "Left" and "Right" buttons to select the display value.
 - Use the "Up" and "Down" buttons to change the display value.
 - Confirm your entries with "OK".

Press "i" to display a help text for the selected area.

Press "X" to cancel your input without saving the new settings. The controller automatically opens again the list.

10.3.2 Default settings

The device controller is shipped with the following default settings. Use the Customer menu to adjust these values to local conditions. In specific cases, it is possible to further adjust the values in the Service menu.

Customer menu

Parameter	Setting	Comment
Language	DE	Display language.
Minimum operating pressure "P ₀ "	1.8 bar	see chapter 8.2 "Reflexomat switching points" on page 15 .
Next maintenance	12 months	Time left to the next due maintenance.
Volt-free contact	YES	see chapter 10.3.3 "Messages" on page 19 .
Make-up		
Make-up "ON"	8 %	
Make-up "OFF"	12 %	
Maximum make-up volume	0 Litres	Only if make-up has been selected in the customer menu with "With water meter Yes".
Maximum make-up time	30 minutes	
Maximum make-up cycles	6 cycles within 2 hours	
Softening (Only if "With softening Yes")		
Shut off make-up	No	In the case of soft water residual capacity = 0
Hardness reduction	8°dH	= Target – Actual
Maximum make-up volume	0 Litres	
Soft water capacity	0 Litres	
Cartridge replacement	18 months	Replace cartridge.

Service menu

Parameter	Setting	Comment
Pressurisation		
Compressor "ON"	P ₀ + 0.3 bar	Differential pressured added to the "P ₀ " minimum operating pressure.
Compressor "OFF"	P ₀ + 0.4 bar	Differential pressured added to the "P ₀ " minimum operating pressure.
"Compressor run time exceeded" message	240 minutes	The message is displayed after the compressor runs for 240 minutes.
Overflow line "CLOSED"	P ₀ + 0.4 bar	Differential pressured added to the "P ₀ " minimum operating pressure.
Overflow line "OPEN"	P ₀ + 0.5 bar	Differential pressured added to the "P ₀ " minimum operating pressure.
Maximum pressure	P ₀ + 3 bar	Differential pressured added to the "P ₀ " minimum operating pressure.
Filling levels		
Insufficient water "ON"	5 %	
Insufficient water "OFF"	12 %	
Solenoid valve in overflow line "CLOSED"	90 %	
Water volume per contact	10 litres/contact	Optional, if a contact water meter is installed (such as Fillset Impulse).

10.3.3 Messages

The messages are impermissible deviations from the normal state. They can be output either via the RS-485 interface or via two floating message contacts. The controller displays the messages with a help text. Message causes can be eliminated by the operator or a specialist workshop. If this is not possible, contact the Reflex Customer Service.

► **Note!**
When the cause for the message is eliminated, you must acknowledge the fault with "OK" at the controller's operator panel.

► **Note!**
Floating contacts, setting in the Customer menu, see chapter 10.3 "Configuring settings in the controller" on page 18 .

To reset a fault message, proceed as follows:

1. Touch the display.
 - The current fault messages are displayed.
2. Touch a fault message.
 - The system displays the possible causes of the fault.
3. When the fault is eliminated, confirm the fault with "OK".

ER Code	Alarm	Causes	Remedy	Alarm reset
01	Min. pressure	<ul style="list-style-type: none"> • Set value exceeded. • Water loss in the system. • Compressor fault. • Controller in Manual mode. 	<ul style="list-style-type: none"> • Check set value in the Customer or Service menu. • Check water level. • Check compressor. • Set the controller to Automatic mode. 	"OK"
02.1 02.2	Compressor 1 insufficient water Compressor 2 insufficient water	<ul style="list-style-type: none"> • Set value not reached. • Make-up disabled. • Air in the system. • Dirt trap clogged. 	<ul style="list-style-type: none"> • Check set value in the Customer or Service menu. • If necessary, manually add water. • Check functioning of the "PV1" solenoid valve. • Clean the dirt trap. 	–

ER Code	Alarm	Causes	Remedy	Alarm reset
03	High water	<ul style="list-style-type: none"> Set value exceeded. Make-up disabled. Water intake through a leak in a thermal transfer medium of the user. Vessels too small. 	<ul style="list-style-type: none"> Check set value in the Customer or Service menu. Check functioning of the "WV1" solenoid valve. Drain water from the primary vessel. Check user's thermal transfer medium for leaks. 	–
04.1 04.2	Compressor 1 Compressor 2	<ul style="list-style-type: none"> Compressor disabled. Fuse defective. 	<ul style="list-style-type: none"> Check functioning of "CO" compressor. <ul style="list-style-type: none"> Check in manual mode, reduce back pressure. Replace the fuse. 	"OK"
05	Compressor run-on time	<ul style="list-style-type: none"> Set value exceeded. Severe water loss in the system. Air lines leaking. Solenoid valve in the overflow line does not close. 	<ul style="list-style-type: none"> Check set value in the Customer or Service menu. Check the water loss and correct, if necessary. Seal any leak in the air system. Check functioning of the "PV1" solenoid valve. 	–
06	Make-up time	<ul style="list-style-type: none"> Set value exceeded. Water loss in the system. Make-up line not connected. Make-up rate insufficient. Make-up hysteresis too high. 	<ul style="list-style-type: none"> Check set value in the Customer or Service menu. Check water level. Connect make-up line. Increase the make-up volume. Correct the make-up hysteresis in the service menu. 	"OK"
07	Make-up cycles	<ul style="list-style-type: none"> Set value exceeded. Leakage in the system. 	<ul style="list-style-type: none"> Check set value in the Customer or Service menu. Seal any leak in the system. 	"OK"
08	Pressure measurement	Controller receives incorrect signal.	<ul style="list-style-type: none"> Connect the plug. Check functioning of the pressure sensor. Check the cable for damage. 	"OK"
09	Level sensor	Controller receives incorrect signal.	<ul style="list-style-type: none"> Check functioning of the load cell. Check the cable for damage. Connect the plug. 	"OK"
10	Maximum pressure	<ul style="list-style-type: none"> Set value exceeded. Pressure relief pipe not functioning. Dirt trap clogged. 	<ul style="list-style-type: none"> Check set value in the Customer or Service menu. Check functioning of the pressure relief pipe. Clean the dirt trap. 	"OK"
11	Make-up volume	<p>Only if "With water meter" is activated in the Customer menu.</p> <ul style="list-style-type: none"> Set value exceeded. Severe water loss in the system. 	<ul style="list-style-type: none"> Check set value in the Customer or Service menu. Check water loss in the system and repair, if necessary. Water volume per contact incorrectly set in the Service menu. 	"OK"
15	Make-up valve	Contact water meter measures without make-up request.	<ul style="list-style-type: none"> Check the make-up valve "WV" for leaks. 	"OK"
16	Power failure	No power.	Connect to power supply.	–
19	Stop > 4 h	Device is in Stop mode for more than 4 hours.	Set the controller to Automatic mode.	–
20	Max. make-up volume	Set value exceeded.	Reset the "Make-up volume" meter in the Customer menu.	"OK"
21	Maintenance recommended	Set value exceeded.	Carry out maintenance.	"OK"
24	Softening	<ul style="list-style-type: none"> Set value for soft water capacity exceeded. Time interval for replacement of the softening cartridge exceeded. 	Replace the softening cartridges.	"OK"
30	I/O module fault	<ul style="list-style-type: none"> I/O module defective Connection between option card and controller faulty. Option card defective. 	Inform Reflex Customer Service.	–
31	EEPROM defective	<ul style="list-style-type: none"> EEPROM defective Internal calculation error 	Inform Reflex Customer Service.	"OK"
32	Undervoltage	Supply voltage too low.	Check power supply.	–
33	Adjustment parameter faulty	EEPROM parameter memory defective.	Inform Reflex Customer Service.	–
34	Main board communication faulty	<ul style="list-style-type: none"> Connecting cable defective. Main board defective. 	Inform Reflex Customer Service.	–
35	Digital input voltage faulty	Short-circuit of input voltage.	Check the wiring at the digital inputs (water meter, for example).	–
36	Analogue input voltage faulty	Short-circuit of input voltage.	Check the wiring at the analogue inputs (pressure/level).	–

- **Note!**
Messages identified with "OK" must be confirmed with the "OK" button on the display. The device operation is otherwise interrupted. The readiness for operation is maintained for all other messages. They are displayed.
- **Note!**
If necessary, you can set the output of messages via a floating contact in the Customer menu.

11 Maintenance

CAUTION

Risk of burns

Escaping hot medium can cause burns.

- Maintain a sufficient distance from the escaping medium.
- Wear suitable personal protective equipment (safety gloves and goggles).

DANGER

Risk of serious injury or death due to electric shock.

If live parts are touched, there is risk of life-threatening injuries.

- Ensure that the system is voltage-free before installing the device.
- Ensure that the system is secured and cannot be reactivated by other persons.
- Ensure that installation work for the electric connection of the device is carried out by an electrician, and in compliance with electrical engineering regulations.

The device is to be maintained annually.

- The maintenance intervals depend on the operating conditions and the degassing times.

The annual maintenance is displayed upon expiry of the set operating time. Use "OK" to acknowledge the "Maintenance recommended" message. Reset the maintenance counter in the Customer menu.

- **Note!**
The maintenance intervals of the secondary vessels can be extended up to 5 years, if no abnormalities have been detected during operation.

- **Note!**
Arrange for maintenance tasks must be carried out only by specialist personnel or Reflex Customer Service.

11.1 Maintenance schedule

The maintenance schedule is a summary of maintenance tasks to be carried out regularly.

Activity	Check	Wait	Clean	Interval
Check for leaks. • "CO" compressor. • Screw connections of the compressed air connections.	x	x		Annually
Check switching points. • Switch on pressure "CO" compressor. • Insufficient water. • Make-up with water.	x			Annually
Clean "ST" dirt trap. – see chapter 11.3.2 "Cleaning the dirt trap" on page 22 .	x	x	x	Depending on the operating conditions
Remove condensate from the primary vessel and the secondary vessels, if applicable. – see chapter 11.3.1 "Cleaning the tanks" on page 22 .	x	x	x	Annually

11.2 Checking switching points

Prerequisite for checking the switching points are the following correct settings:

- Minimum operating pressure P_0 , see chapter 8.2 "Reflexomat switching points" on page 15 .
- Level sensor at the primary vessel.

Preparation

1. Switch to Automatic mode.
2. Close the cap valves upstream of the vessels.
3. Record the displayed filling level (value in %).
4. Drain the water from the vessels.

Check cut-in pressure

5. Check the cut-in and cut-out pressure of the "CO" compressor.
 - The compressor cuts in at $P_0 + 0.3$ bar.
 - The compressor cuts out at $P_0 + 0.4$ bar.

Check make-up "On"

6. If necessary, check the make-up value displayed at the controller.
 - The automatic make-up is activated at a level display of 8 %.

Checking Insufficient water "On"

7. Switch off the water make-up and continue to drain the water from the vessels.
8. Check the displayed value for the "Insufficient water" filling level message.
 - Insufficient water "On" is displayed at the controller at a minimum filling level of 5 %.
9. Switch to Stop mode.
10. Switch off the main switch.

Cleaning the vessels

If necessary, remove condensate from the vessels, see chapter 11.3.1 "Cleaning the tanks" on page 22 .

Activating the device

11. Switch on the main switch.
12. Switch to Automatic mode.
 - Depending on the filling level and pressure, the "CO" compressor and the automatic make-up will be switched on.
13. Slowly open the cap valves upstream of the vessels and secure them against unintended closing.

Checking Insufficient water "Off"

14. Check the displayed value for the Insufficient water "Off" filling level message.
 - Insufficient water "Off" is displayed at the controller at a minimum filling level of 8 %.

Check make-up "Off"

15. If necessary, check the make-up value displayed at the controller.
 - The automatic make-up is deactivated at a level display of 12 %.

Maintenance is completed.

- **Note!**
If no automatic make-up is connected, manually fill the vessels with water up to the noted level.

- **Note!**
The setting values for pressurisation, filling levels and make-up can be found in the chapter Default settings, see chapter 10.3.2 "Default settings" on page 19 .

11.3 Cleaning

11.3.1 Cleaning the tanks



Risk of injury due to pressurised liquid

Injuries can occur during maintenance work if the connections have been installed incorrectly because condensate under pressure can suddenly escape.

- Ensure proper connections for the draining of condensate.
- Wear suitable personal protective equipment (safety gloves and safety goggles, for example).

Regularly clean the primary vessel and the secondary vessels to remove condensate. The cleaning intervals depend on the local operational conditions.

Vessels with replaceable diaphragm

1. Close the cap valve in front of the vessels.
2. Record the displayed level value at the controller and empty the vessel of water and compressed air.
3. Switch off the main switch and withdraw the mains plug.
4. Open the drain taps at the vessels and drain the condensate.
 - If more than 5 litres of water or condensate are discharged, you must check the vessel.
 - Check the diaphragm for rupture.
 - Check the vessel interior walls for corrosion damage.

CAUTION – Risk of injury caused by escaping pressurised liquid. Injuries can occur during maintenance work if the connections have been installed incorrectly because condensate under pressure can suddenly escape.

5. Close the vessels' drain taps.
6. Connect the mains plug and switch on the main switch.
7. Open the cap valve of the vessels and secure against unauthorised "closing".
8. Fill water and compressed air into the vessels until the recorded level value is reached.

Maintenance is completed.



Note! Check the installation location of the vessels for sufficient ventilation if the vessel interior wall are damaged by corrosion, see chapter 7.2 "Preparatory work" on page 9.

11.3.2 Cleaning the dirt trap

Regularly clean the "ST" dirt trap. The cleaning intervals depend on the local operational conditions.

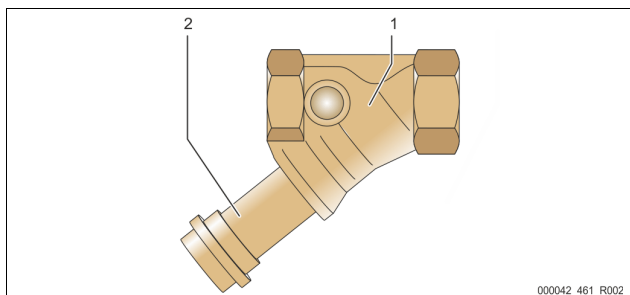

1	"ST" dirt trap	2	Dirt trap insert
---	----------------	---	------------------

1. Switch to Stop mode.
 - Press "Stop" on the controller's operator panel.
2. Close the ball valves upstream and downstream of the "ST" (1) dirt trap.
3. Slowly unscrew the dirt trap insert (2) from the dirt trap in order for the residual pressure to escape from the pipeline segment.
4. Pull the mesh from the dirt trap insert and rinse it with clear water. Use a soft brush for cleaning.
5. Re-insert the mesh into the dirt trap insert, check the gasket for damage, and screw the dirt trap insert back into the housing of the "ST" (1) dirt trap.
6. Re-open the ball valves upstream and downstream of the "ST" (1) dirt trap.
7. Switch to Automatic mode.
 - Press "Auto" on the controller's operator panel.



Note! Clean all other installed dirt traps (in the Reflex Fillset, for example).

11.4 Inspection

11.4.1 Pressure-bearing components

Comply with all applicable national regulations for the operation of pressure equipment. De-pressurise all pressurised components prior to inspection (see disassembly information).

11.4.2 Inspection prior to commissioning

In Germany, follow the Industrial Safety Regulation [Betriebssicherheitsverordnung] Section 15 and Section 15 (3) in particular.

11.4.3 Inspection intervals

Recommended maximum inspection intervals for operation in Germany pursuant to Section 16 of the Industrial Safety Regulation [Betriebssicherheitsverordnung] and the vessel classification of the device in diagram 2 of the Directive 2014/68/EC, applicable in strict compliance with the Reflex Installation, Operation and Maintenance Manual.

External inspection:

No requirement according to Annex 2, Section 4, 5.8.

Internal inspection:

Maximum interval according to Annex 2, Section 4, 5 and 6; if necessary, suitable replacement actions are to be taken (such as wall thickness measurement and comparison with the design specification which may be requested from the manufacturer).

Strength test:

Maximum interval according to Annex 2, Section 4, 5 and 6. Furthermore, compliance with Section 16 of the Industrial Safety Regulation and Section 16 (1) in particular, in conjunction with Annex 2, Section 4, 6.6 and Annex 2, Section 4, 5.8, must be ensured.

The actual intervals must be specified by the operating company based on a safety evaluation taking into consideration the actual operating conditions, experience with the mode of operation and charging material and the applicable national regulations for the operation of pressure equipment.

12 Disassembly

⚠ DANGER

Risk of serious injury or death due to electric shock.

If live parts are touched, there is risk of life-threatening injuries.

- Ensure that the system is voltage-free before installing the device.
- Ensure that the system is secured and cannot be reactivated by other persons.
- Ensure that installation work for the electric connection of the device is carried out by an electrician, and in compliance with electrical engineering regulations.

⚠ CAUTION

Risk of burns on hot surfaces

Hot surfaces in heating systems can cause burns to the skin.

- Wait until hot surfaces have cooled down or wear protective safety gloves.
- The operating authority is required to place appropriate warning signs in the vicinity of the device.

⚠ CAUTION

Risk of injury due to pressurised liquid

If installation or maintenance work is not carried out correctly, there is a risk of burns and other injuries at the connection points, if pressurised hot water or steam suddenly escapes.

- Ensure proper disassembly.
- Ensure that the system is de-pressurised before performing the disassembly.

- Prior to dismantling, block off all "water"-side connections to the device.
- De-pressurise the device by venting it.

1. Disconnect the system from the power supply and secure it against unintended reactivation.
2. Disconnect the power cable of the device from the power supply.
3. Disconnect and remove all cables from the terminals of the device controller.

⚠ DANGER – Risk of serious injury or death due to electric shock. Some parts of the device's circuit board may still be live with 230 V even after the device has been physically isolated from the power supply by pulling out of the mains plug. Before you remove the covers, completely isolate the device controller from the power supply. Verify that the main circuit board is voltage-free.

4. Disconnect the secondary vessel (if provided) on the water side from the system and the primary vessel.
5. Open the discharge ports at the vessels until water and compressed air are completely removed.
6. Undo all hose and pipe connections to the vessels and the control unit of the device to the system and remove them completely.
7. If necessary, remove the vessels and the control unit from the system area.

13 Annex

13.1 Reflex Customer Service

Central customer service

Central telephone number: +49 (0)2382 7069 - 0

Customer Service extension: +49 (0)2382 7069 - 9505

Fax: +49 (0)2382 7069 - 9523

E-mail: service@reflex.de

Technical Hotline

For questions about our products

Telephone number: +49 (0)2382 7069-9546

Monday to Friday 8:00 to 16:30

13.2 Conformity and standards

Device conformity declarations are available on the Reflex homepage.

www.reflex-winkelmann.com/konformitaetserklaerungen

Alternatively, scan the QR code:



13.3 Guarantee

The respective statutory guarantee regulations apply.

EN **Installation and commissioning certificate** - This device has been installed and commissioned in accordance with the instructions provided in the operating manual. The settings in the controller match the local conditions.



Typ / Type:	
P ₀	
P _{SV}	
Fabr. Nr. / Serial-No.	



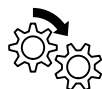



Thinking solutions.

Reflex Winkelmann GmbH
Gersteinstraße 19
59227 Ahlen, Germany



+49 (0)2382 7069-0

+49 (0)2382 7069-9546

A WINKELMANN BRAND
BUILDING+INDUSTRY

www.reflex-winkelmann.com